

CAPiTA | MEG

25/26

WHAT STANDS IN THE WAY BECOMES THE WAY

CAPiTA

 **The MotherShip™**

HANDCRAFTED IN AUSTRIA
WITH 100% CLEAN ENERGY.

XXV

HARD CHOICES

WALK

EASY LIFE

WALK

CAPITA MFG

The MotherShip™
 Powered by the river and the sun.

Team

The MotherShip™ Connection

MEGA DEATH.....9
 • Tech

MEGA MERC.....12
 • Tech

MEGA SPLIT.....15
 • Tech

SUPER D.O.A.....18
 • Tech

Resort

AERONAUT.....26
 • Tech

D.O.A.....32
 • Tech
 • Tech – Wide

BIRDS OF A FEATHER.....39
 • Tech

OUTERSPACE LIVING.....43
 • Tech

PARADISE.....47
 • Tech

Freestyle

INDOOR SURVIVAL.....53
 • Tech

ULTRAFEAR.....57
 • Tech

DARK HORSE.....61
 • Tech

PATHFINDER.....65
 • Tech – Wide

SPACE METAL FANTASY.....69
 • Tech

Freeride

BLACK SNOWBOARD OF DEATH.....76
 • Tech

KAZU KOKUBO PRO.....80
 • Tech

MERCURY.....84
 • Tech

THE NAVIGATOR.....87
 • Tech

NAVIGATOR SPLIT.....93
 • Tech

THE EQUALIZER.....99
 • Tech

Youth

CHILDREN OF THE POW.....104
 • Tech

CHILDREN OF THE GNAR.....108
 • Tech

JESS KIMURA MINI.....112
 • Tech

SCOTT STEVENS MINI.....115
 • Tech

MICRO MINI.....119
 • Tech

Spring Break

POWDER GLIDER.....124
 • Tech

POWDER RACERS.....127
 • Tech

POWDER TWIN.....130
 • Tech

RESORT TWIN.....134
 • Tech

STAIRMASTER.....138
 • Tech

SLUSH SLASHERS.....142
 • Tech

Rental

R-SERIES.....146
 • Tech

Softgoods

Technology

Wood Core Composition.....156

Fiberglass.....157

Additives.....158

Base + Sidewall.....159

Camber Overview.....160

Sidecut.....161

Printing Tech.....162

Tech Overview

Board Matrix

Overview

Resort.....166

Freestyle.....168

Freeride.....169

Youth.....171

Spring Break.....172

Rental.....173



The MotherShip™

HANDCRAFTED IN AUSTRIA WITH 100% CLEAN ENERGY.



The MotherShip™

All CAPITA snowboards are made here—in a beautiful valley in Austria where it smells like fresh alpine air and supernatural magic.



ZERO
CO₂ Emissions



ZERO
Ozone Depletion
Potential



ZERO
Global Warming
Potential

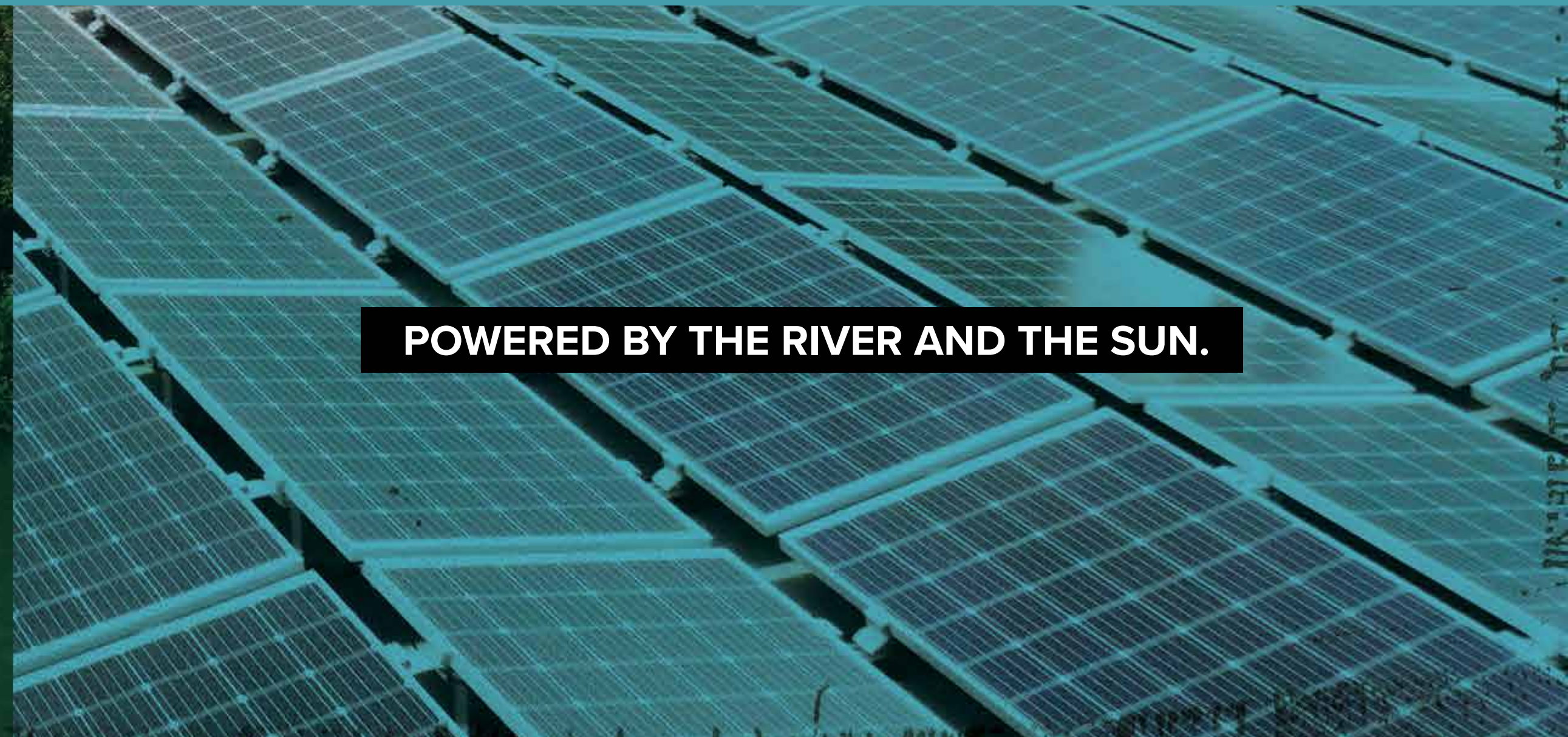

POWERED BY THE RIVER AND THE SUN.

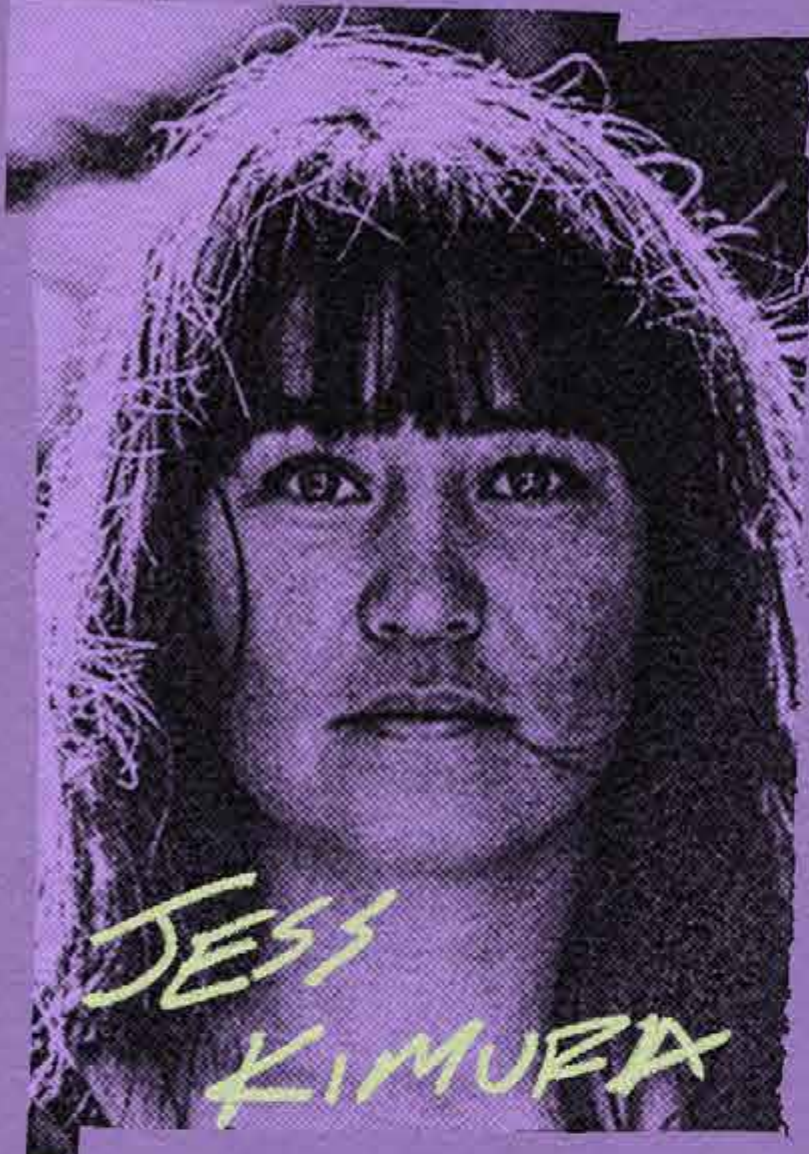

JESS
KIMURA

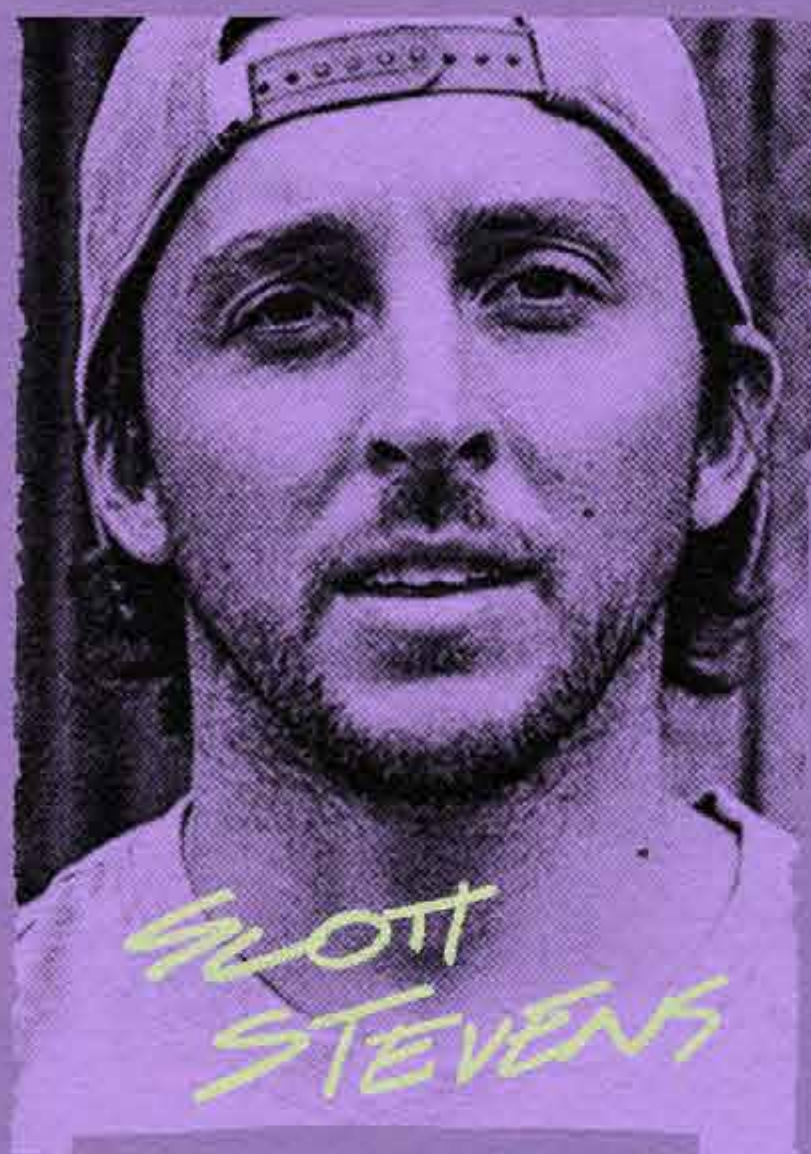

SLOTT
STEVENS

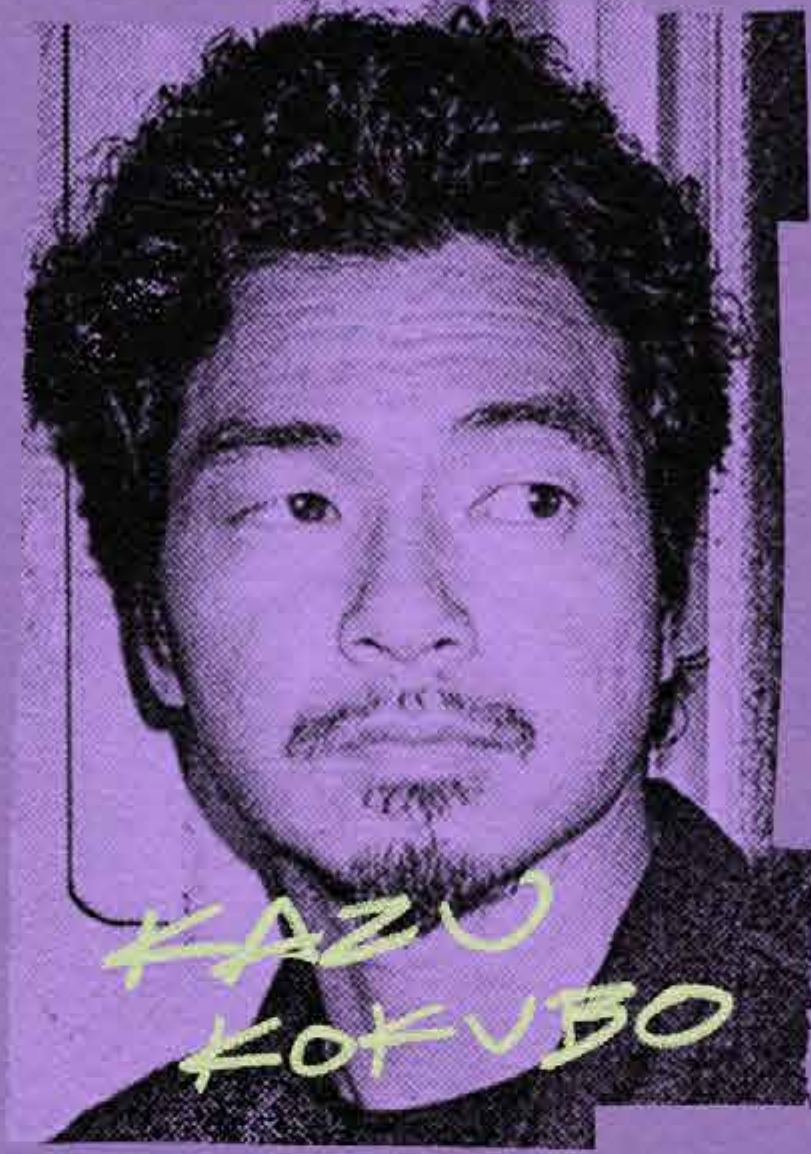

KAZU
KOKUBO

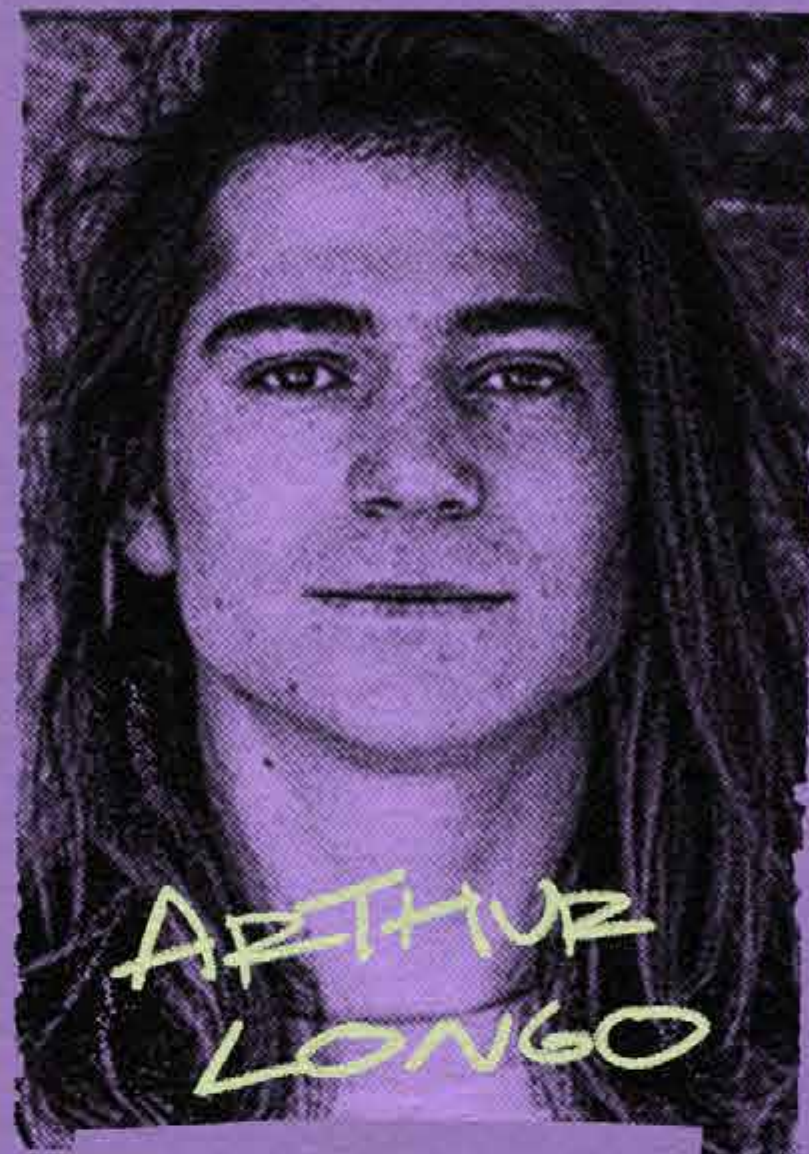

ARTHUR
LONGO

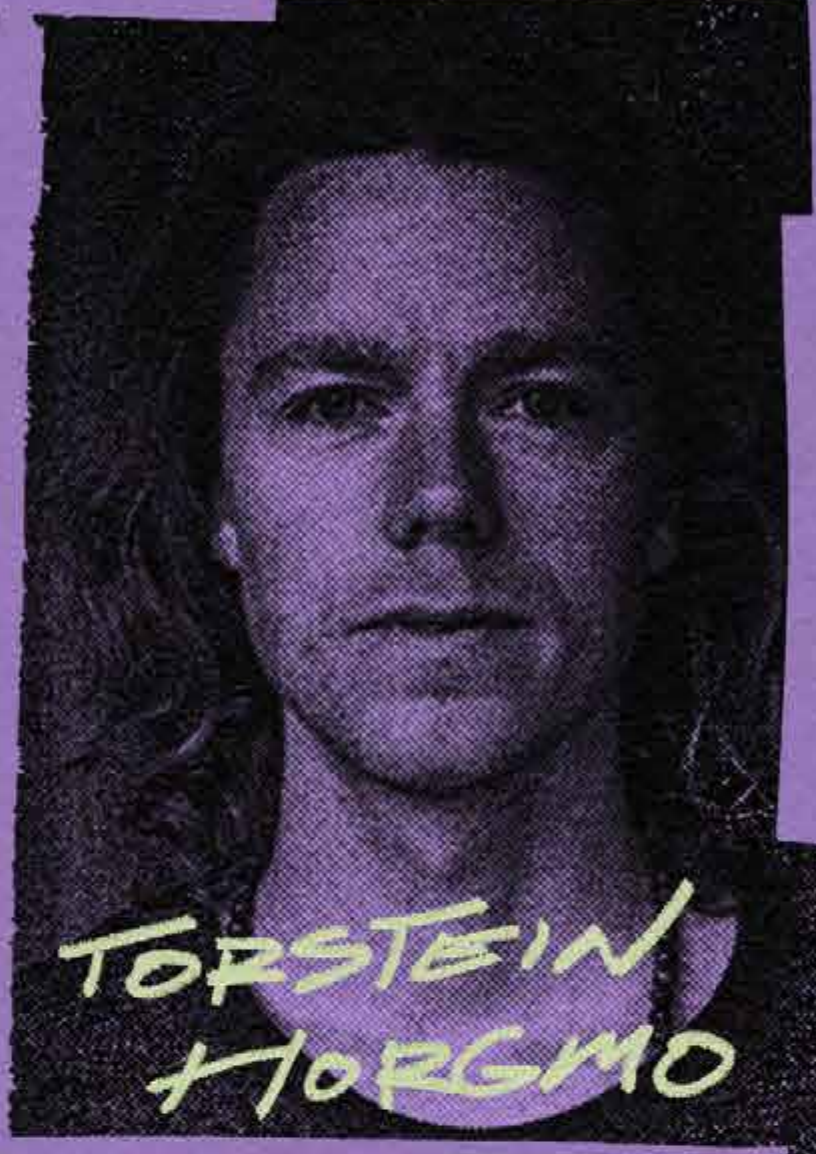

TORSTEIN
HORGMO

PRO TEAM

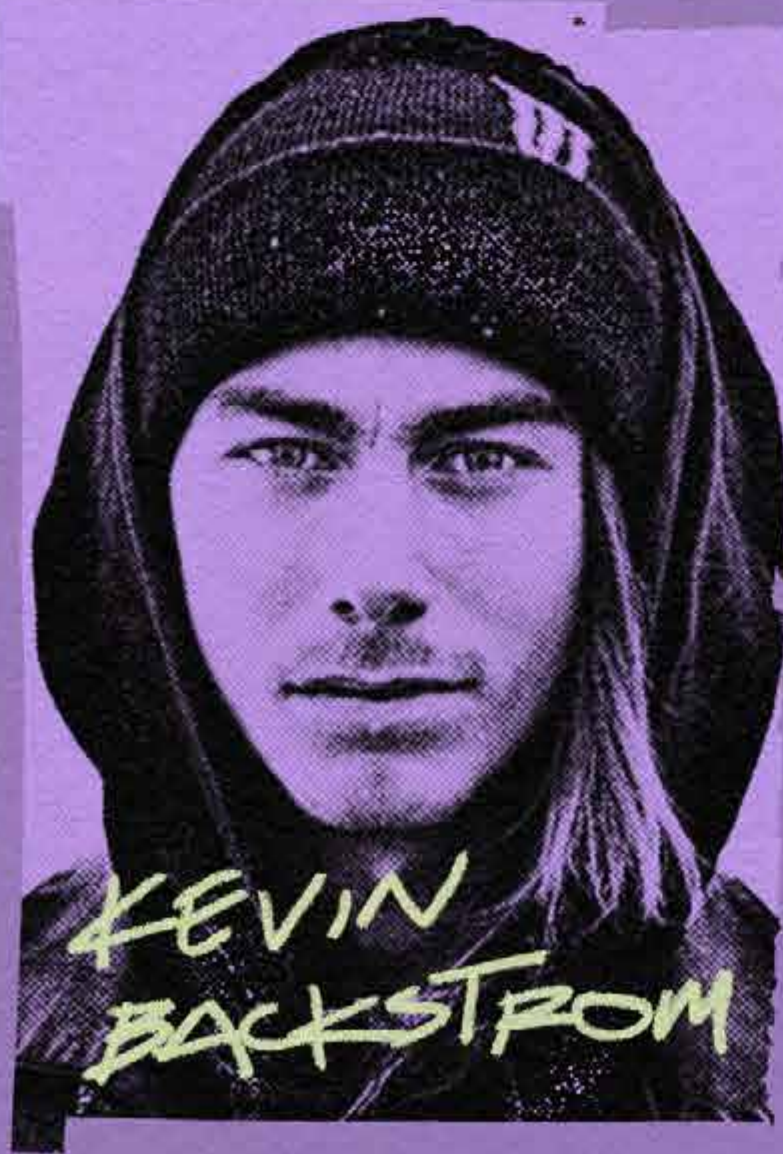

KEVIN
BACKSTROM

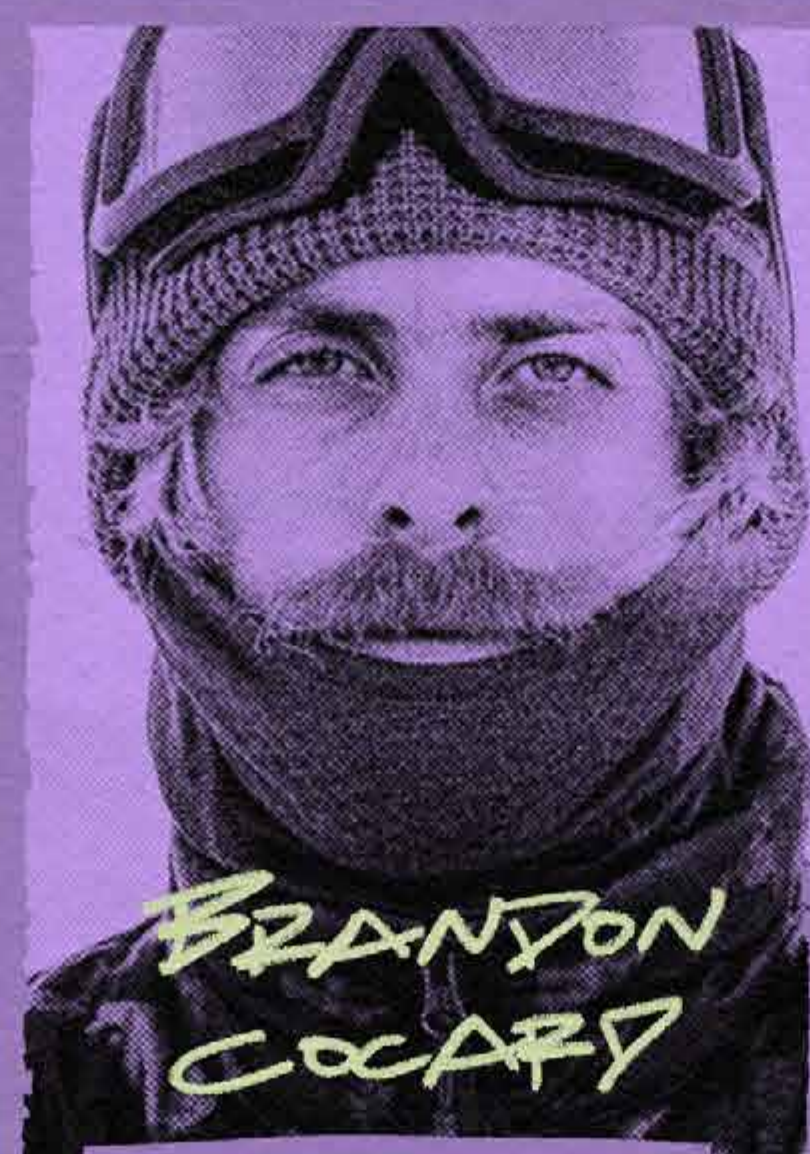

BRANDON
COCARY

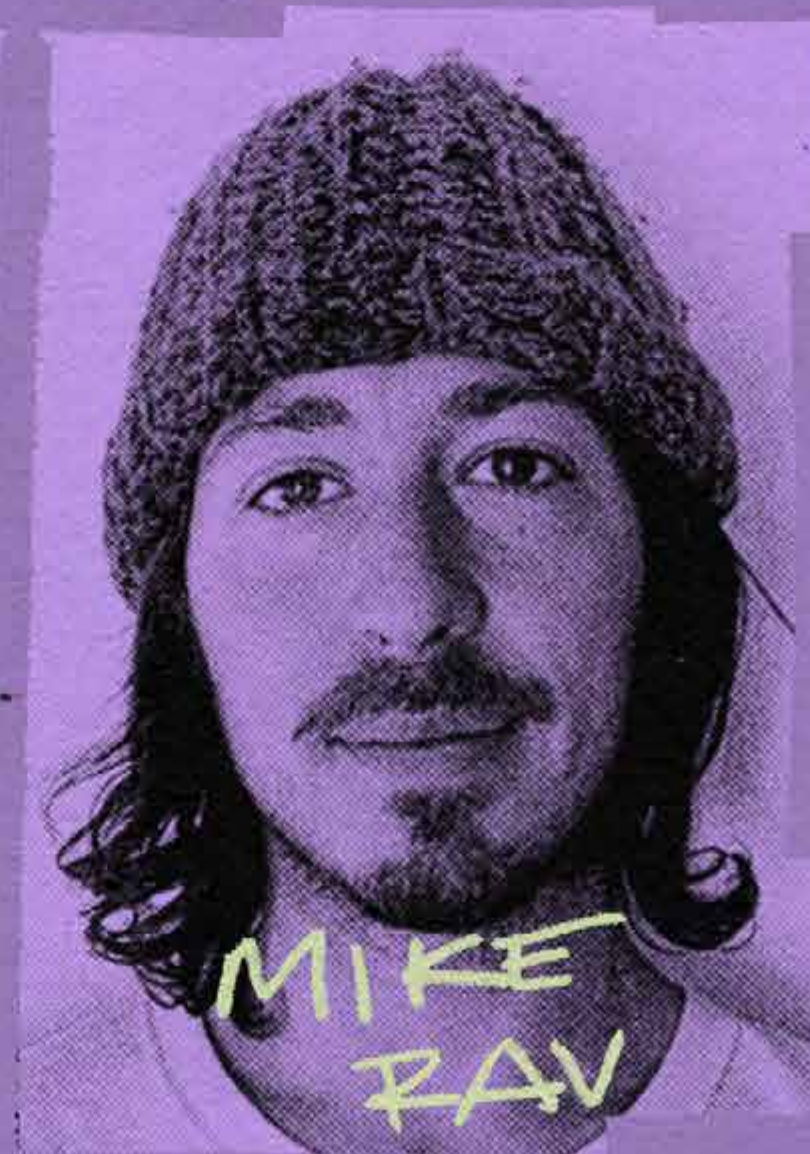

MIKE
RAV

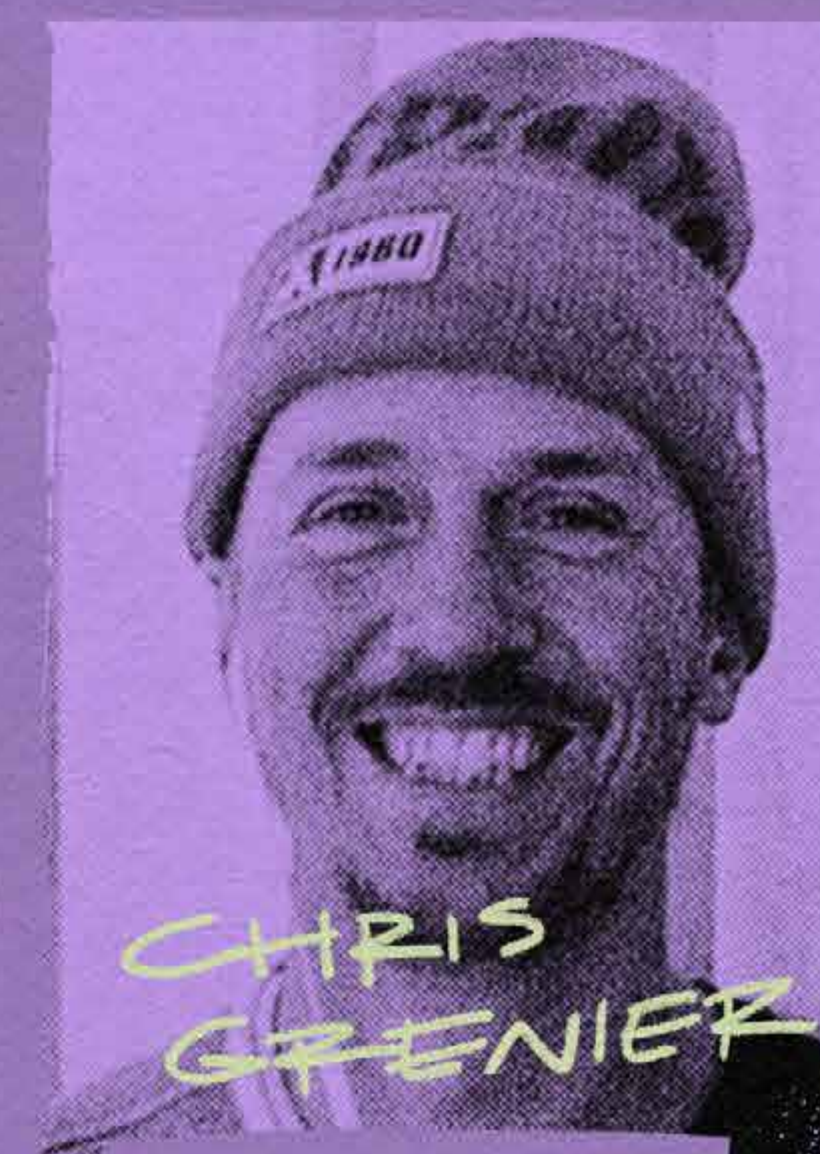

CHRIS
GRENIER

© 2008 Olympic Team USA

MI: sub
Mia Brooks
Miles Fallon
Henna Ikola
Benny Milam



MIA
BROOKS

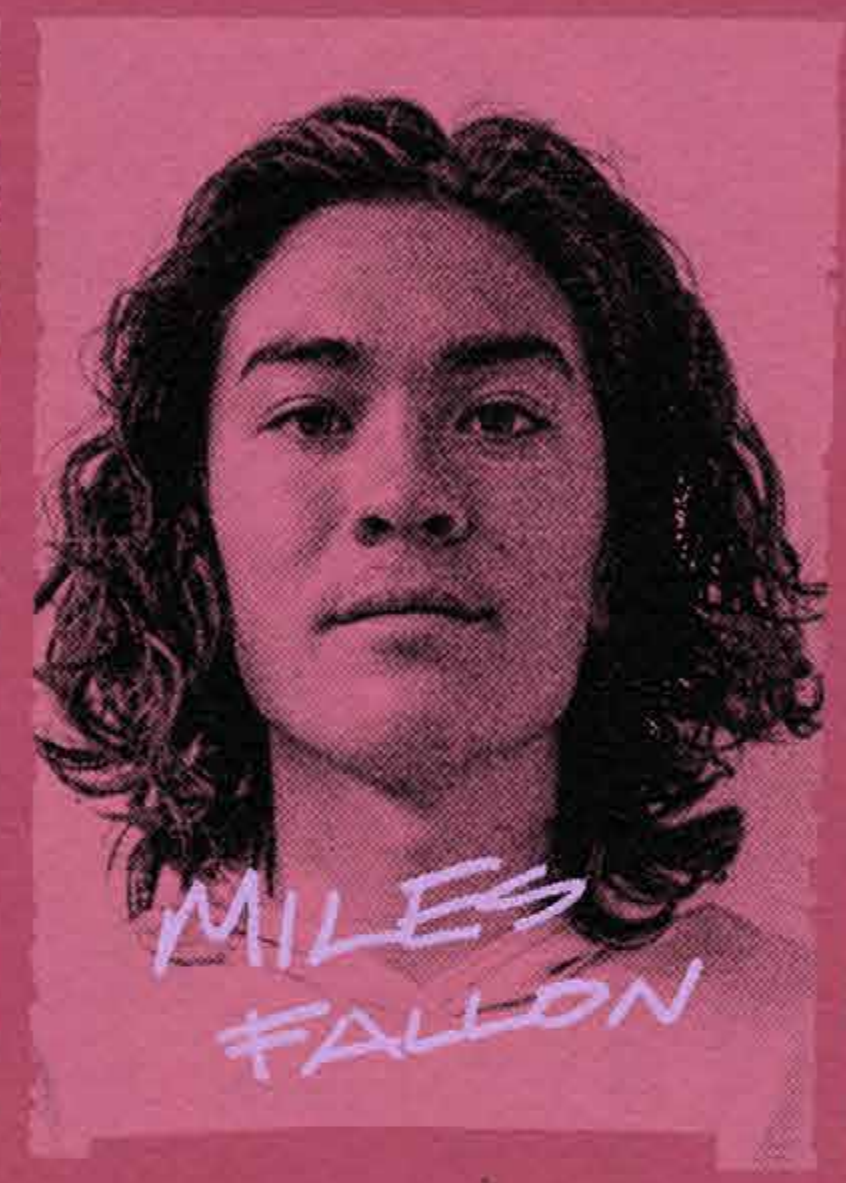

MILES
FALLON



HENNA
IKOLA

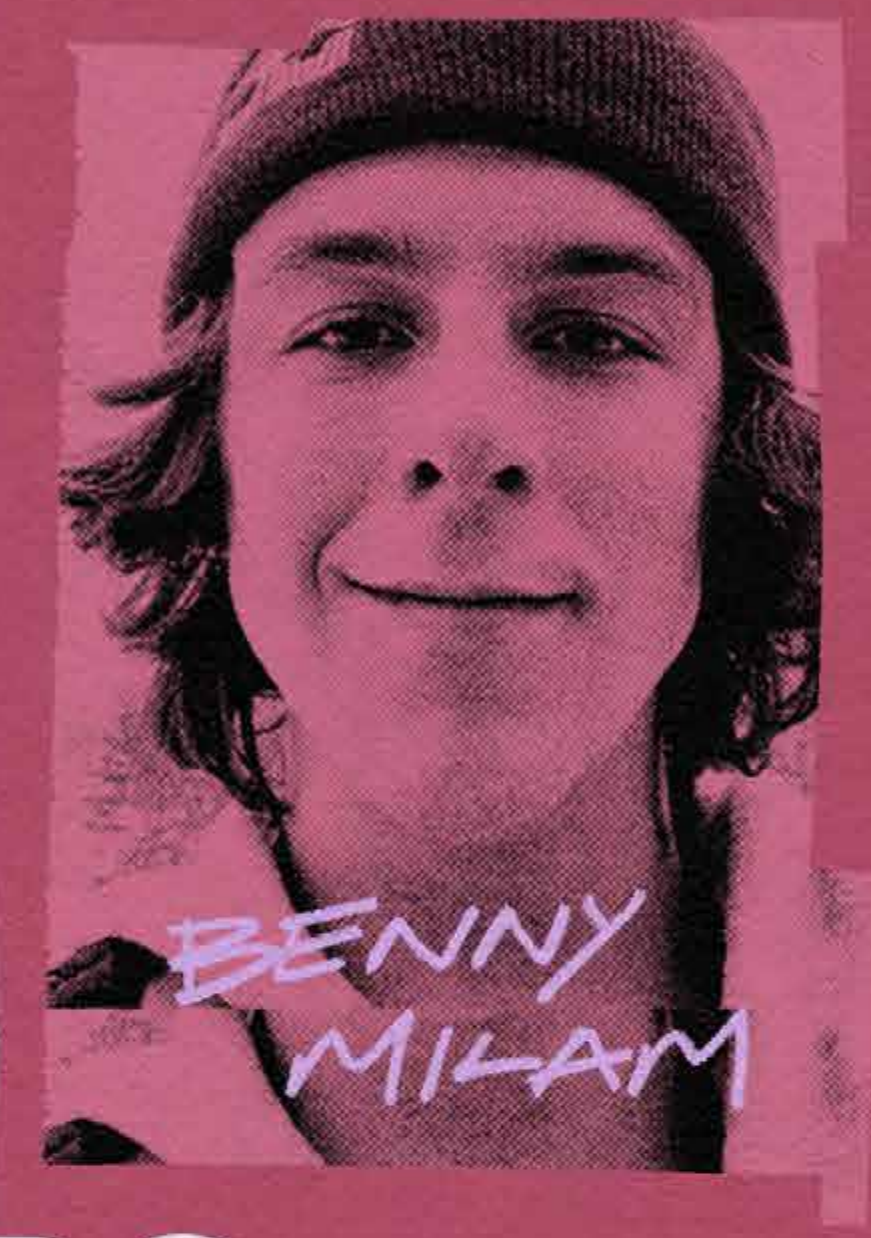

BENNY
MILAM

PATHFINDERS

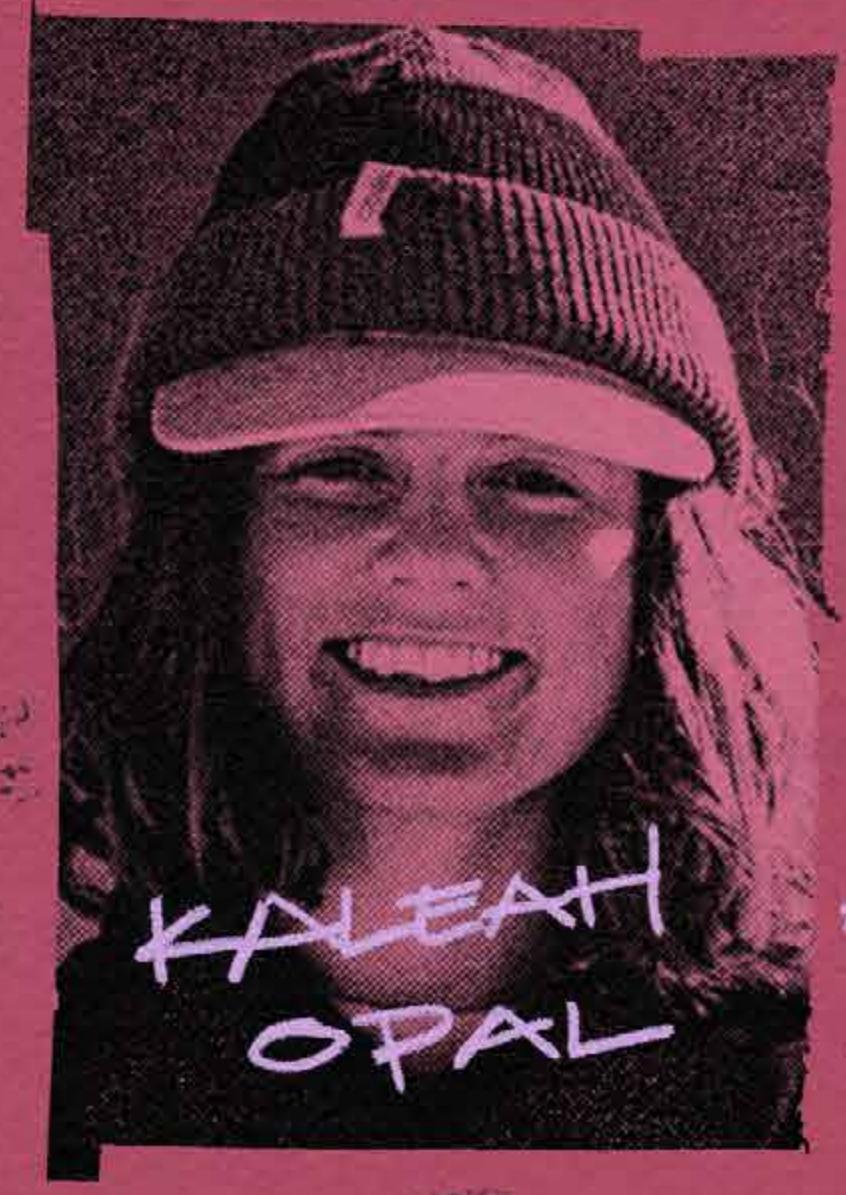

KALEAH
OPAL

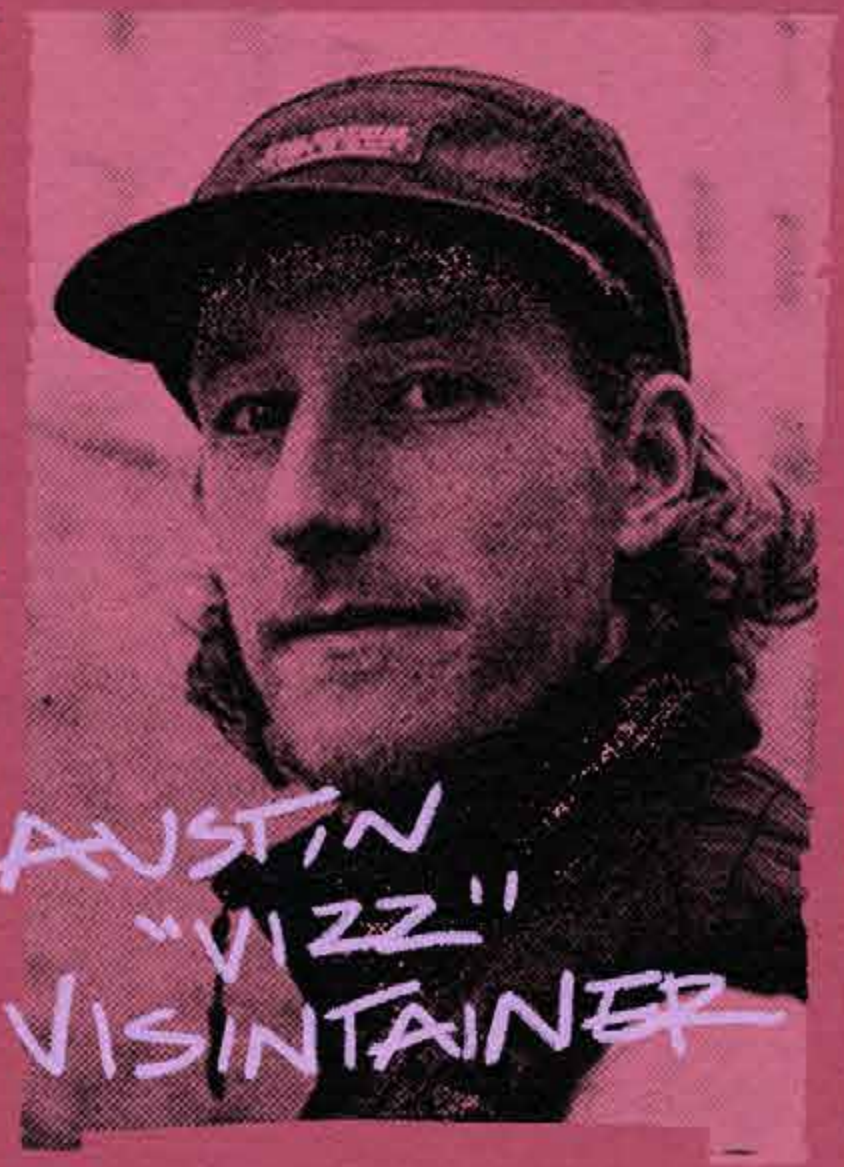

AUSTIN
"VIZZ"
VISINTAINER

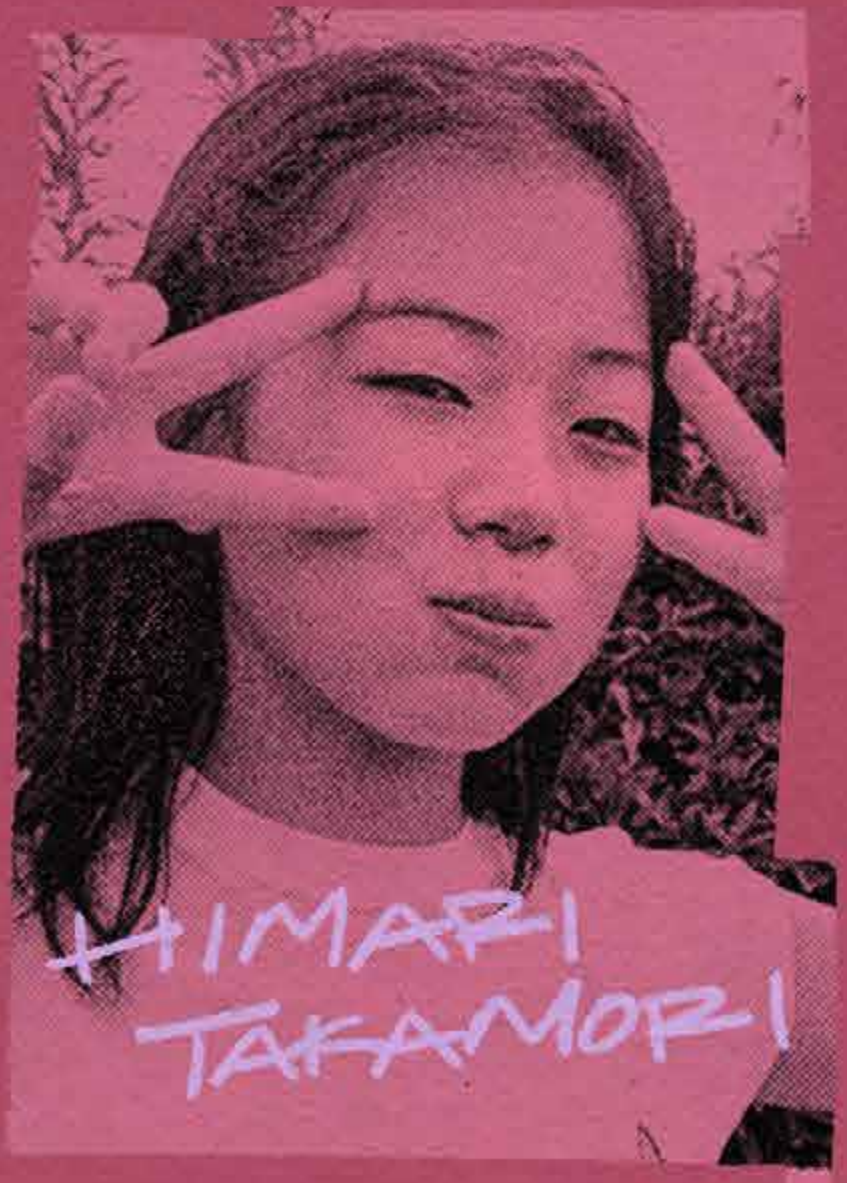

HIMARI
TAKAMORI



YURA
MURASE

Opal
Vizz

Yura



The MotherShip™ CONNECTION



The MotherShip™ CONNECTION



MEGA DEATH



MEGA MERC



MEGA SPLIT



SUPER D.O.A.



MEGA DEATH

All-Mtn + Freeride / Directional / Hybrid Camber

Inspired by the legacy of *The Black Snowboard of Death*, yet custom designed for an unmatched ultralight and powerful performing ride, we present the *MEGA DEATH* — a high-end, high-tech freeride machine unlike anything else.

The *MEGA DEATH* is quite simply the board that everyone wants, but not everyone will get to have. A truly versatile, high-performance freeride machine — ready to charge anything you dare point down.

MEGA DEATH



SPEED TRIBE

CONTENTS

TMC

RESORT

FREESTYLE

FREERIDE

YOUTH

SPRING BREAK

SOFTGOODS

TECH

MEGA DEATH

All-Mtn + Freeride / Directional / Hybrid Camber

MFRFB

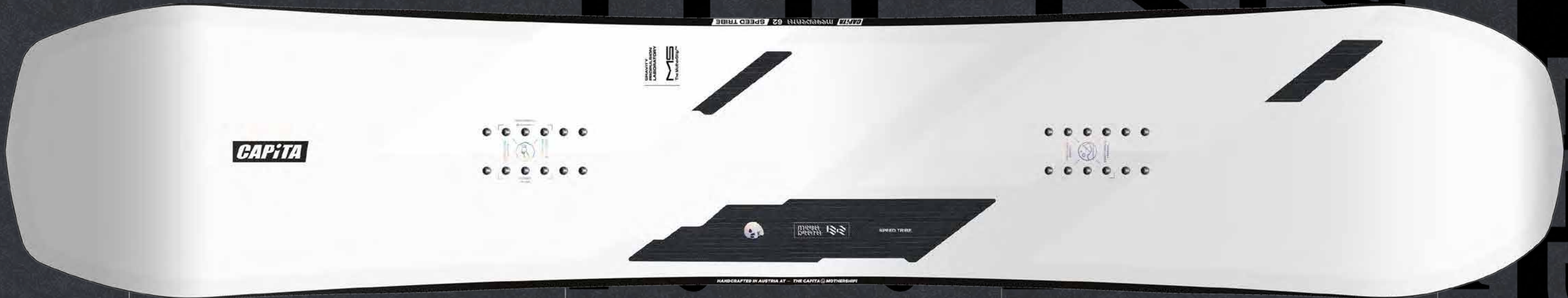

SPEED TRIBE

MEGA DEATH



For the advanced freerider with the technical ability to utilize the ultimate in premium performance.

RIDER TYPE:
All-Mtn / Freeride

SHAPE:
Directional
0.8" Setback

SIDECUT:
New Age
Progressive
Death Grip™

FLEX:
Directional
6.5

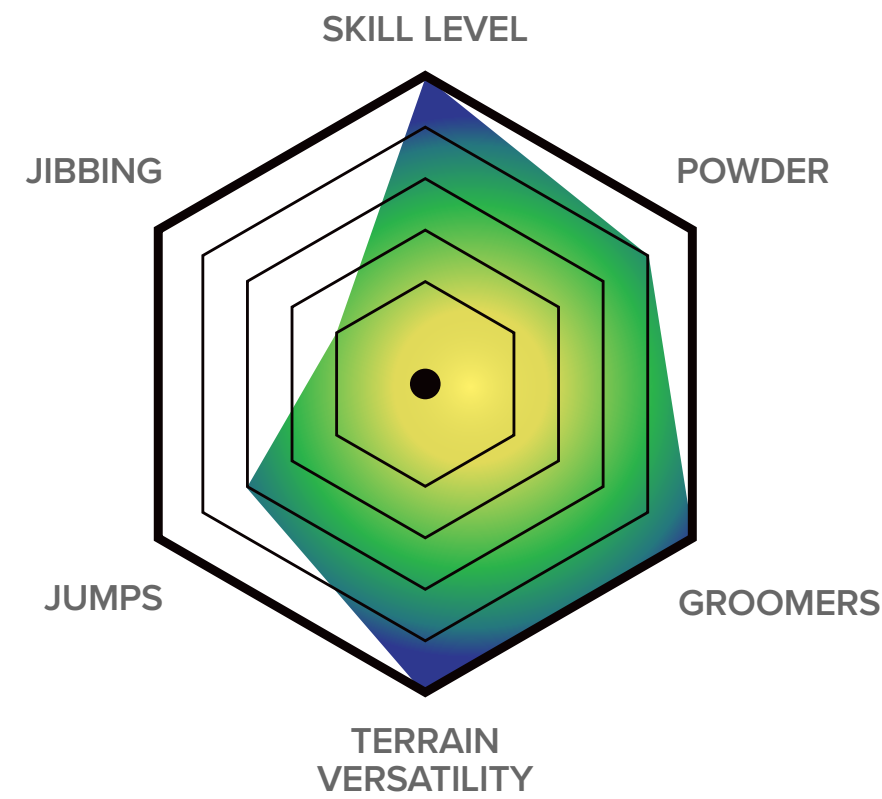

HYBRID CAMBER:
Alpine V1 Directional + Flat Kick Tech

The *ALPINE V1 Profile* design features mid-body camber with a flat tail and a reverse cambered nose. This allows for tons of pop and stability on hard pack while increasing float and landing power, improving the rider's performance in deep snow. The camber runs longer in the tail—providing extra power for the ascent or for larger riders drawn to a dedicated wide series.

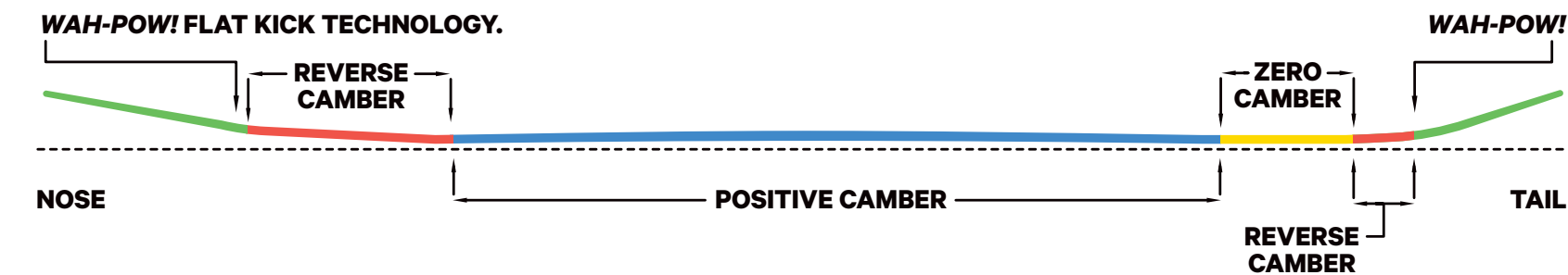

LENGTH	EFFECTIVE EDGE (mm)	WAIST	NOSE / TAIL	TAPER	SIDECUT	REF. STANCE (cm / inches)	SUGGESTED WEIGHT (lbs / kg)
156	1197	25.6	29.6 / 29.5	1.1	8.2 / 7.8 / 7.6	55.9 / 22.0	130-190 / 59-86
159	1221	25.9	30.0 / 29.9	1.1	8.4 / 8.0 / 7.8	55.9 / 22.0	140-200 / 63-90
162	1245	26.2	30.4 / 30.3	1.1	8.6 / 8.2 / 8.0	58.4 / 23.0	150-210 / 68-95
157 W	1205	26.4	30.5 / 30.4	1.1	8.2 / 7.8 / 7.7	55.9 / 22.0	140-200 / 63-90
161 W	1237	26.7	30.9 / 30.8	1.1	8.5 / 8.1 / 8.0	58.4 / 23.0	150-210 / 68-95
165 W	1269	27.0	31.2 / 31.1	1.1	8.8 / 8.4 / 8.2	58.4 / 23.0	160-220 / 72-99
NEW! 169 W	1301	27.4	31.7 / 31.6	1.1	9.0 / 8.6 / 8.5	58.4 / 23.0	170-230 / 77-104

OVERVIEW

Tech Features

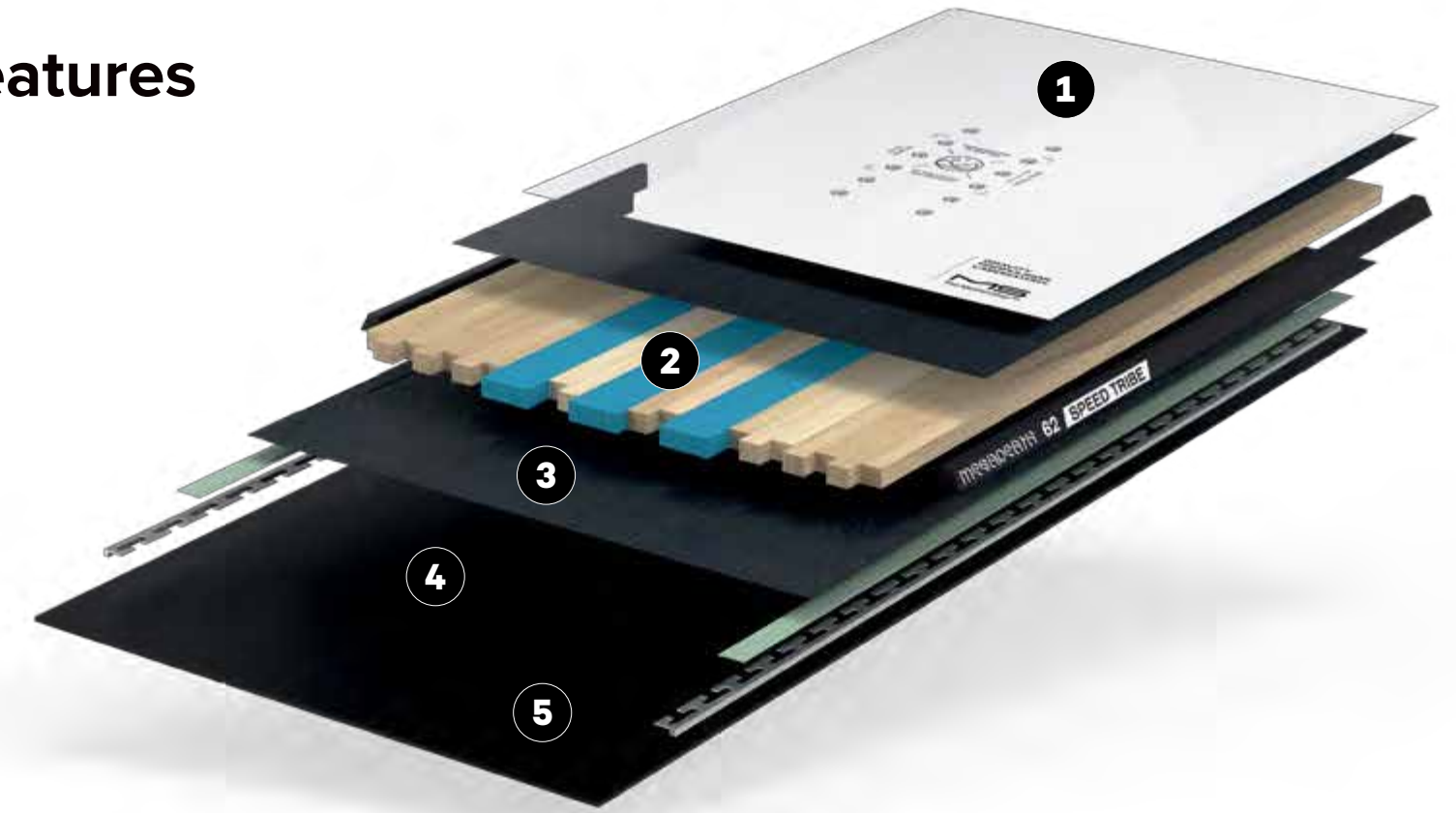

1 TOPSHEET TECH:
• Screen Print
• Metallic Underlay

2 CORE:
THERMOPOLYMER
STARSHIP CORE™

3 GLASS + RESIN:
PURE MEGACARBON™
MARINE GRADE
EPOXY RESIN

4 BASE:
MEGADRIVE™ XT
• Die-cut

5 BASE TECH:
INLAID ALLOY
SKID PLATES

• DEATH GRIP™ SIDECUT

MOONSHOT
OMNI-TUNE™

CORE:

- PET
- PURE MEGACARBON™
- MEGA-PREMIUM POPLAR

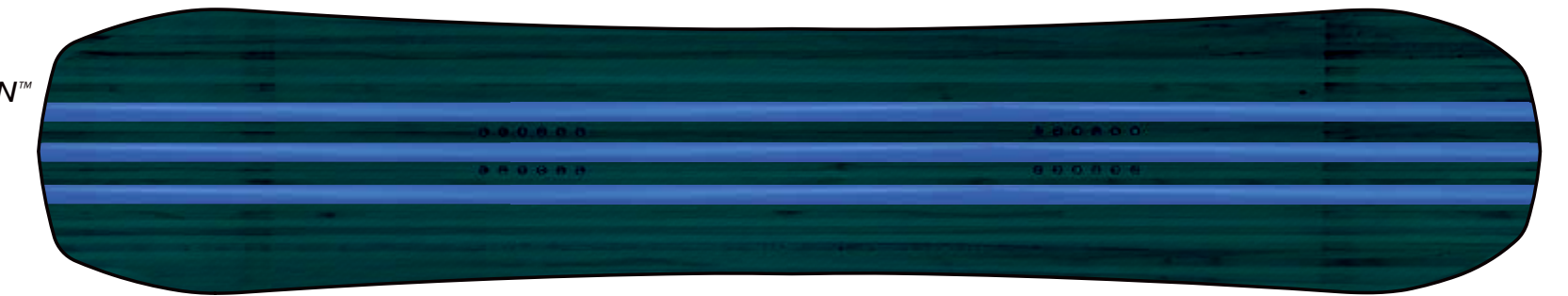

The *Mega Death* is a series unlike anything else. Ultra-premium and ultra-feather-weight, this series features the pinnacle of technical advancements from The MotherShip™. This beast of a board will propel you to unimaginable speeds with its Thermopolymer Starship Core™ wrapped in Pure Megacarbon™ and MEGADRIVE™ XT base with factory-direct Moonshot Omni Tune™ stone grind.

MEGA MERC

All-Mtn + Freeride / Directional / Hybrid Camber

Behold! The consummate anytime, any-place, all-terrain, snow-slaying device; The *MEGA MERC*. Inspired by the on-slope versatility of the Mercury series, the *MEGA MERC* mimics its proven technical design lines while packing a powerful punch of serious construction upgrades.

Designed for power when you want it, and float when you need it, the *MEGA MERC* is the ultimate, ultra-premium, shred-anything snowboard you can trust to handle it all.

MEGA MERC

All-Mtn + Freeride / Directional / Hybrid Camber

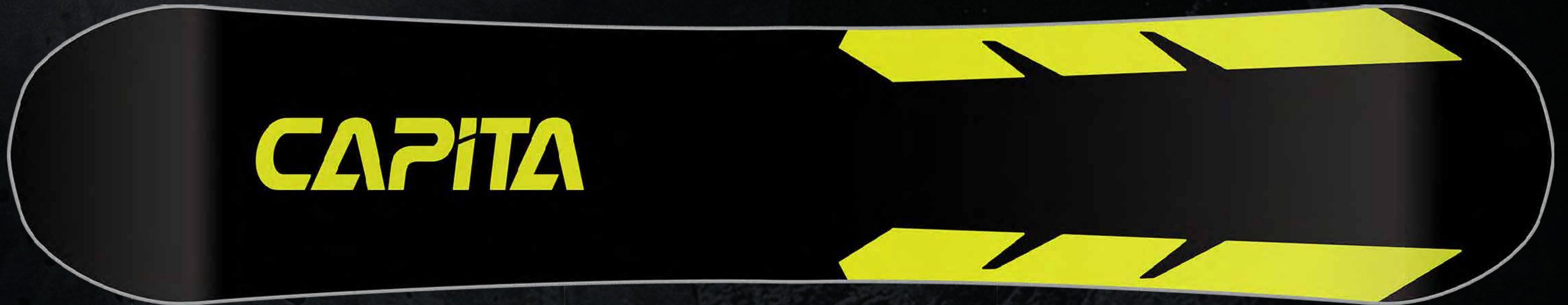

MEGA MERC



The ultimate any time, any day, any condition, advanced freeride machine.

RIDER TYPE:
All-Mtn / Freeride

SHAPE:
Directional
0.5" Setback

SIDECUT:
New Age
Progressive
Death Grip™

FLEX:
Directional
7

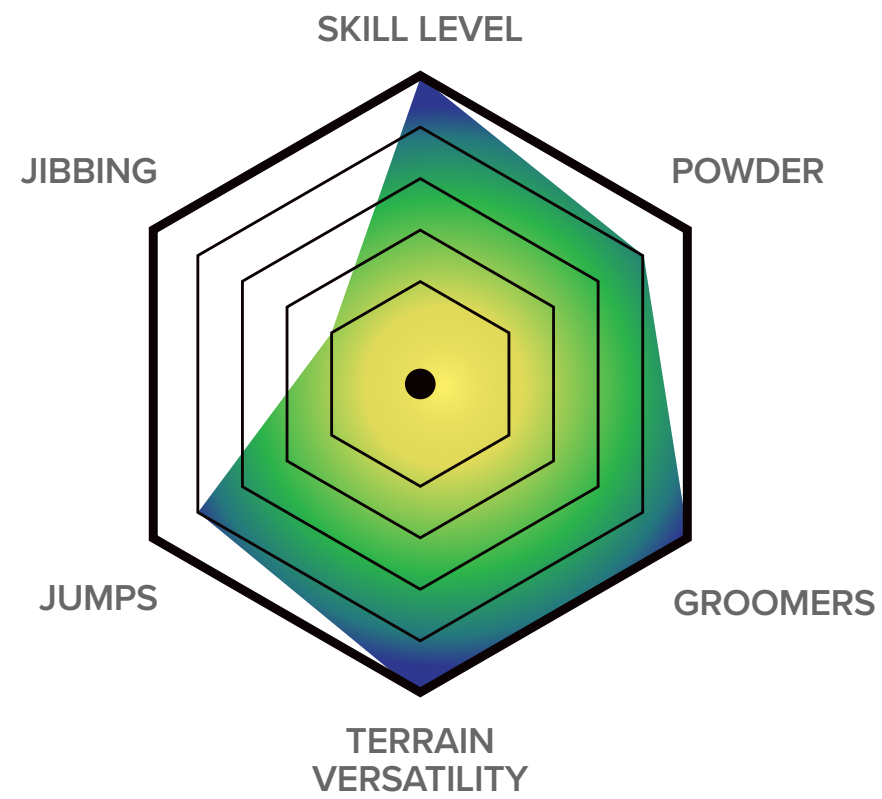

HYBRID CAMBER:
Resort V2 Directional + Flat Kick Tech

This revolutionary all-terrain shape provides the best of both worlds. It has a raised camber platform through the inserts to retain high-speed edge hold through variable terrain, elevated contact points to land and float in powder, and Flat Kick tip and tail arcs for faster, more aggressive transitions.

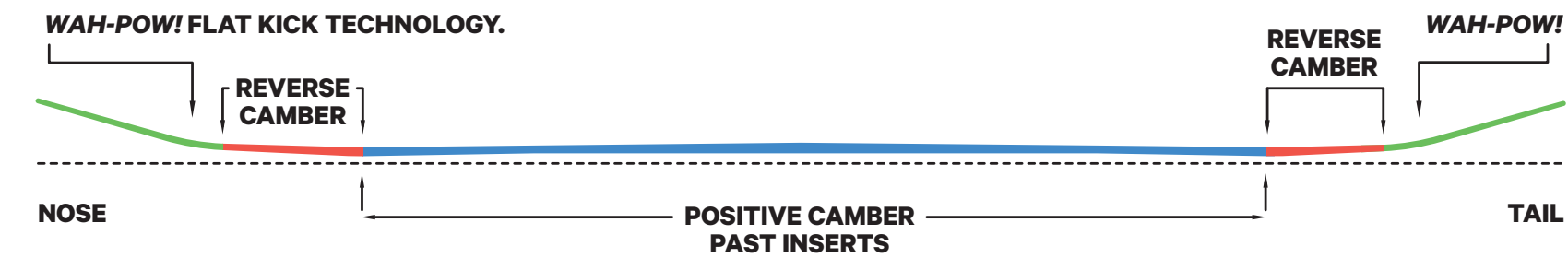



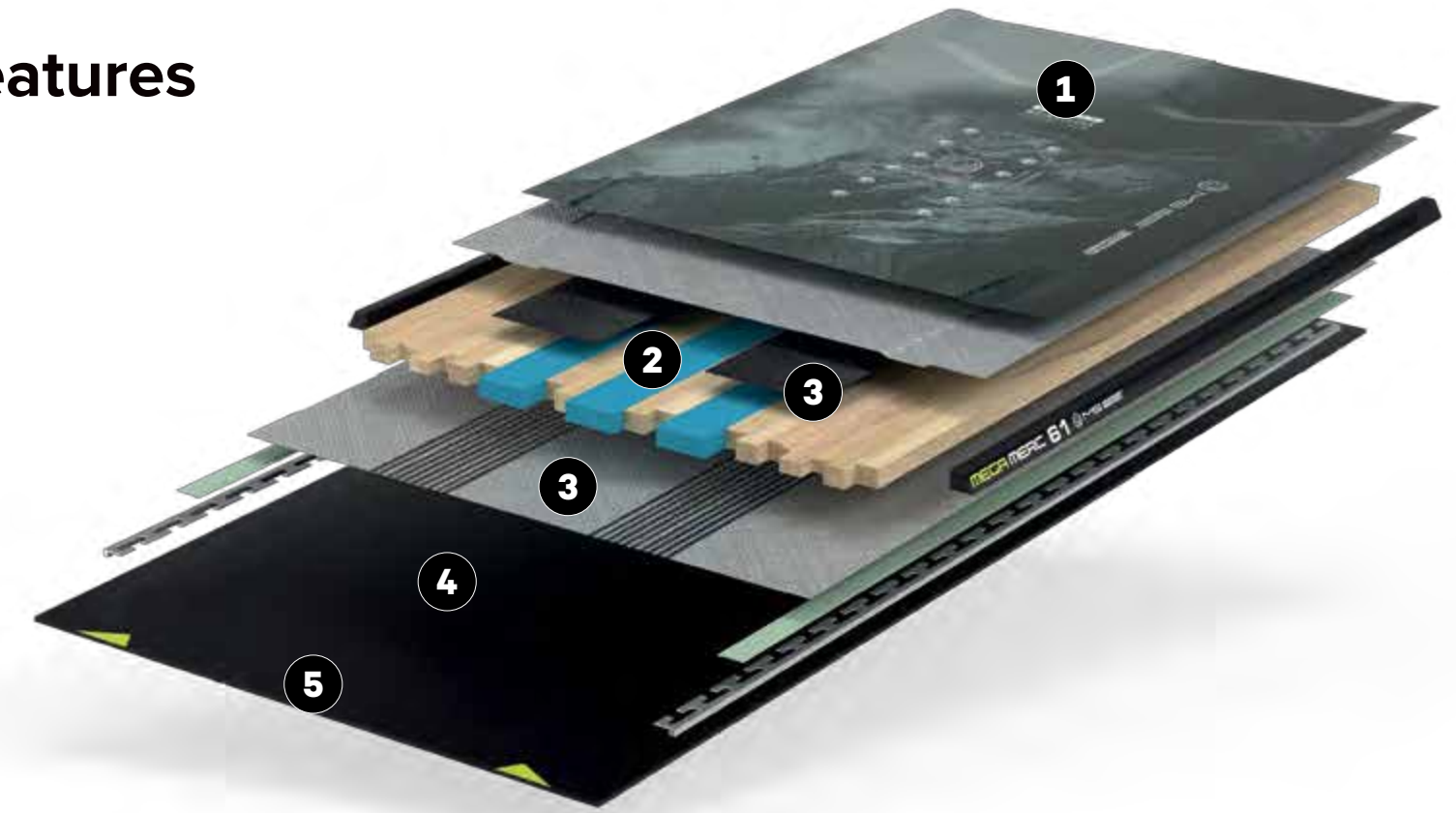

LENGTH	EFFECTIVE EDGE (mm)	WAIST	NOSE / TAIL	SIDECUT	REF. STANCE (cm / inches)	SUGGESTED WEIGHT (lbs / kg)
153	1183	25.3	29.6 / 29.6	7.5 / -1.5 / 7.5	53.3 / 21.0	100-160 / 45-72
155	1199	25.5	29.8 / 29.8	7.7 / -1.5 / 7.7	55.9 / 22.0	120-180 / 54-81
157	1215	25.7	30.1 / 30.1	7.8 / -1.5 / 7.8	55.9 / 22.0	130-190 / 59-86
159	1223	25.9	30.3 / 30.3	8.0 / -1.5 / 8.0	55.9 / 22.0	140-200 / 63-90
161	1247	26.1	30.6 / 30.6	8.1 / -1.5 / 8.1	58.4 / 23.0	160-220 / 72-99
156 W	1207	26.1	30.5 / 30.5	7.8 / -1.5 / 7.8	55.9 / 22.0	120-180 / 54-81
158 W	1223	26.3	30.7 / 30.7	7.9 / -1.5 / 7.9	55.9 / 22.0	130-190 / 59-86
160 W	1239	26.5	30.9 / 30.9	8.0 / -1.5 / 8.0	58.4 / 23.0	140-200 / 63-90

OVERVIEW

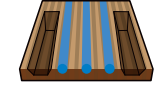
Tech Features



- 
1 TOPSHEET TECH: **MEGALITE SKIN™ TOPSHEET**
 • Digital + Screen Print
 • Chrome Silver Underlay
- 
2 CORE: **3D THERMOPOLYMER STARSHIP CORE™**
- 
3 GLASS + RESIN: **HYBRID CARBON HOLYSHEET™ TRI/TRI + MEGACARBON™ MAGIC BEAN™ RESIN**
- 
4 BASE: **MEGADRIVE™ XT**
 • Die-cut
- 
5 BASE TECH: **MOONSHOT OMNI-TUNE™**
- DEATH GRIP™ SIDECUT**

CORE:

- PET
- MEGACARBON™
- MEGA-PREMIUM POPLAR

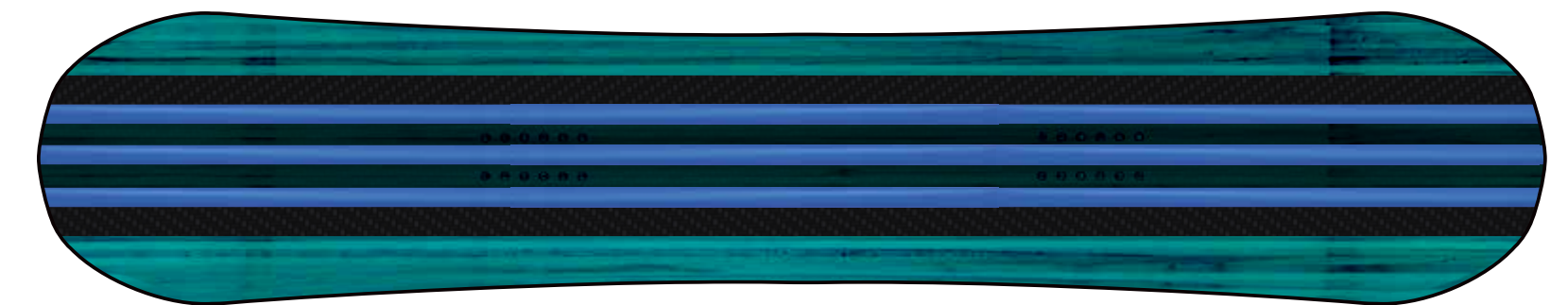

Ultralight and ultra-versatile the *Mega Merc* harnesses its 3D Thermopolymer Starship Core™ with an all-new Hybrid HolySheet™ Tri/Tri MEGACARBON™ configuration and MEGADRIVE™ XT base for unparalleled all-mountain performance.

MEGA SPLIT

Split Board / All-Mtn + Freeride / Directional Hybrid Camber

Inspired by the renowned Mercury shape, and the *MEGA MERC*'s high-end construction attributes, the *MEGA SPLIT* is custom engineered to be one of the lightest-weight and best-performing split-boards in the world. Unlock worlds of new terrain and endless adventures with the *MEGA SPLIT*.

GRAVITY
PROPULSION
LABORATORY

MS

46°34'45.9"N 13°36'53.8"E

The MotherShip™

MEGA SPLIT

Split Board / All-Mtn + Freeride / Directional / Hybrid Camber

GRAVITY
PROPULSION
LABORATORY



MS
36'53.8" E
Ship™

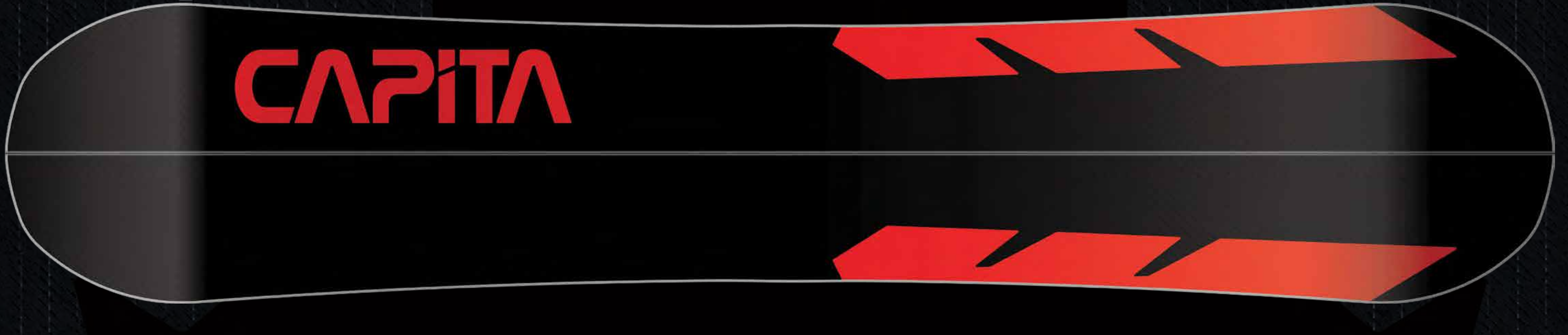

MEGA SPLIT



The ultimate splitboard for riders prioritizing mega-lightweight tech.

RIDER TYPE:
All-Mtn / Freeride

SHAPE:
Directional
0.8" Setback

SIDECUT:
New Age
Progressive
Death Grip™

FLEX:
Directional
7

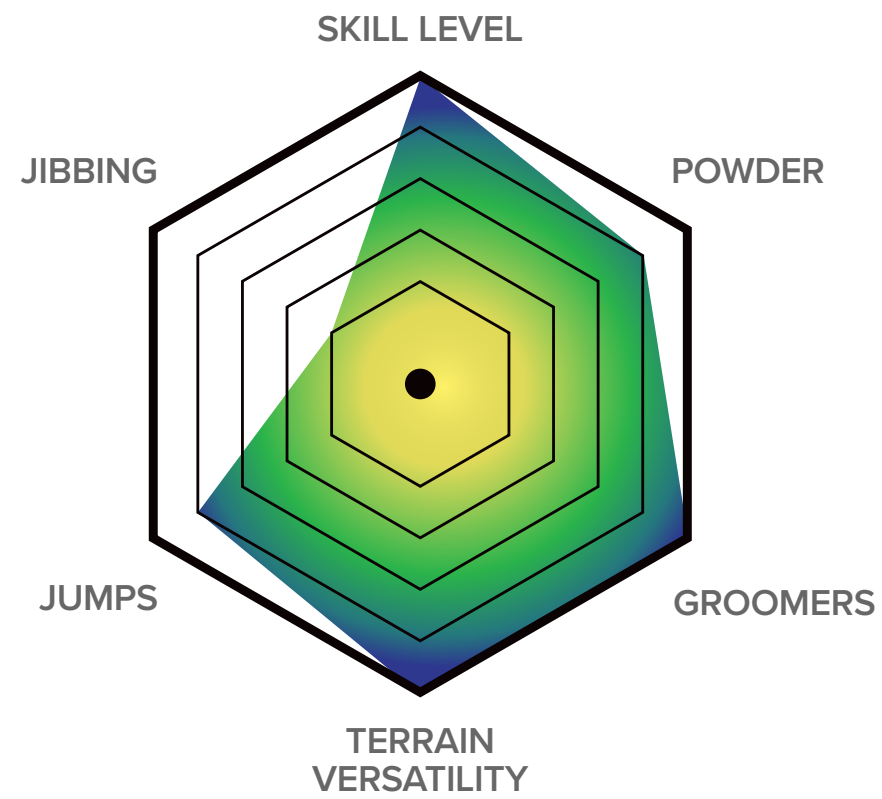

HYBRID CAMBER:
Resort V2 Directional + Flat Kick Tech

This revolutionary all-terrain shape provides the best of both worlds. It has a raised camber platform through the inserts to retain high-speed edge hold through variable terrain, elevated contact points to land and float in powder, and Flat Kick tip and tail arcs for faster, more aggressive transitions.

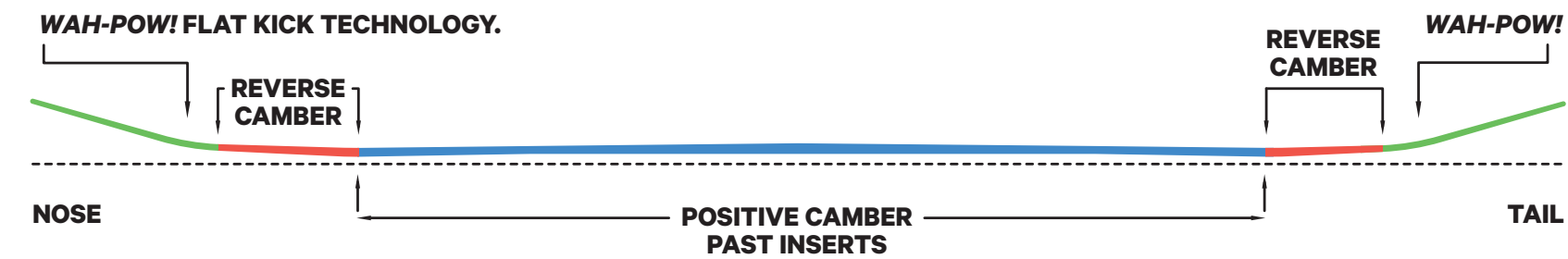

LENGTH	EFFECTIVE EDGE (mm)	WAIST	NOSE / TAIL	SIDECUT	REF. STANCE (cm / inches)	SUGGESTED WEIGHT (lbs / kg)
155	1199	25.5	29.8 / 29.8	7.7 / -1.5 / 7.7	57.5 / 22.6	120-180 / 54-81
157	1215	25.7	30.1 / 30.1	7.8 / -1.5 / 7.8	57.5 / 22.6	130-190 / 59-86
159	1223	25.9	30.3 / 30.3	8.0 / -1.5 / 8.0	61.5 / 24.2	140-200 / 63-90
161	1247	26.1	30.6 / 30.6	8.1 / -1.5 / 8.1	61.5 / 24.2	160-220+ / 72-99+

OVERVIEW

Tech Features



- 1** TOPSHEET TECH: **MEGALITE SKIN™ TOPSHEET**
 - Digital + Screen Print
 - Chrome Silver
- 2** CORE: **3D ASCEND 1 SPLIT CORE™**
- 3** GLASS + RESIN: **PURE MEGACARBON™ EPOXY RESIN**
- 4** BASE: **MEGADRIVE™ XT**
 - Die-cut
- 5** BASE TECH: **MOONSHOT OMNI-TUNE™**
 - DEATH GRIP™ SIDECUT
- 6** **EXPEDITION SKINS** BY MONTANA
 - INCLUDED: UNION EXPEDITION SKINS BY MONTANA™
 - UNION PRO CLIPS AND HOOKS

CORE:

- PURE MEGACARBON™
- PAULOWNIA
- POPLAR

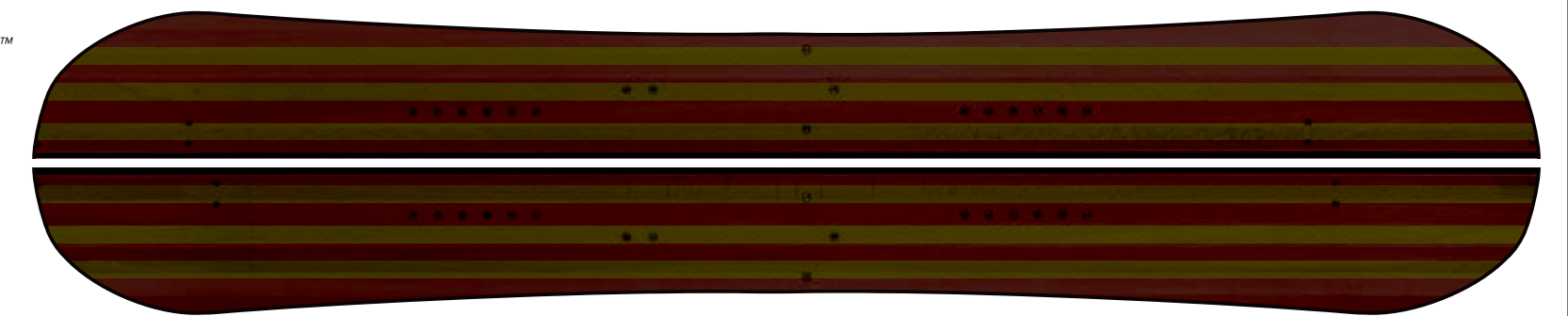

The ultralight *Mega Split* is powered by a 3D Ascend 1 Split Core™, Pure MEGACARBON™, and a new MEGADRIVE™ XT with Moonshot Omni-Tune™ making this the greatest performing, featherlight construction in the industry.

ALL NEW 3D SHAPES!

SUPER D.O.A.

Resort / True Twin / Hybrid Camber

Bear witness to the technically supreme, supercharged, *SUPER D.O.A.* redesigned for 2026 with a new 3D shape.

This game-changing, turbocharged wonder of the slopes has absorbed the shaping and camber theory from the most beloved snowboard in the galaxy and cranked up the construction to "Don't Panic" levels.

Designed for the intermediate to advanced all-terrain resort rider seeking the award-winning geometry of the *D.O.A.* series, in a lighter, more energetic, and responsive chassis, the *SUPER D.O.A.* isn't just any snowboard; it's a hyperdrive equipped, improbability-fueled snow-surfing machine that can help you go faster, and edge quicker.



SUPER D.O.A.

Resort / True Twin / Hybrid Camber

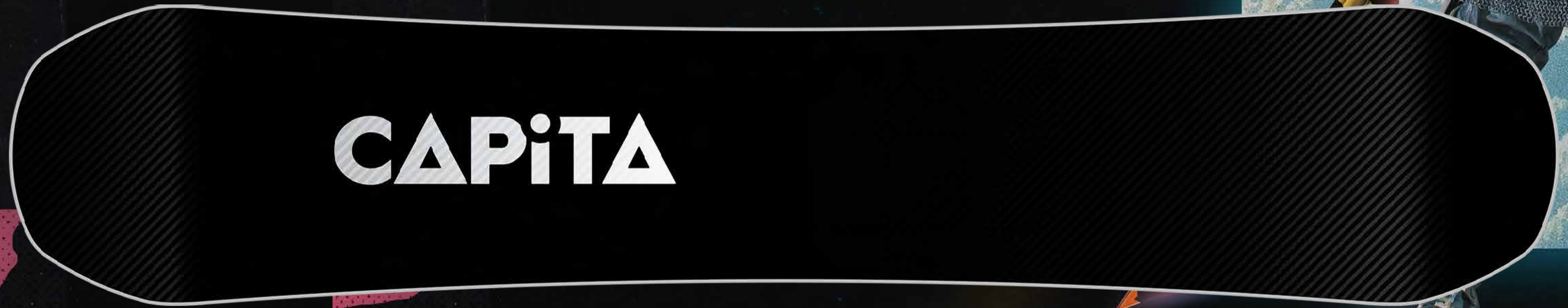

SUPER D.O.A.

Resort / True Twin / Hybrid Camber



152



154



156



158



160



BASE



SUPER D.O.A.

Resort / True Twin / Hybrid Camber

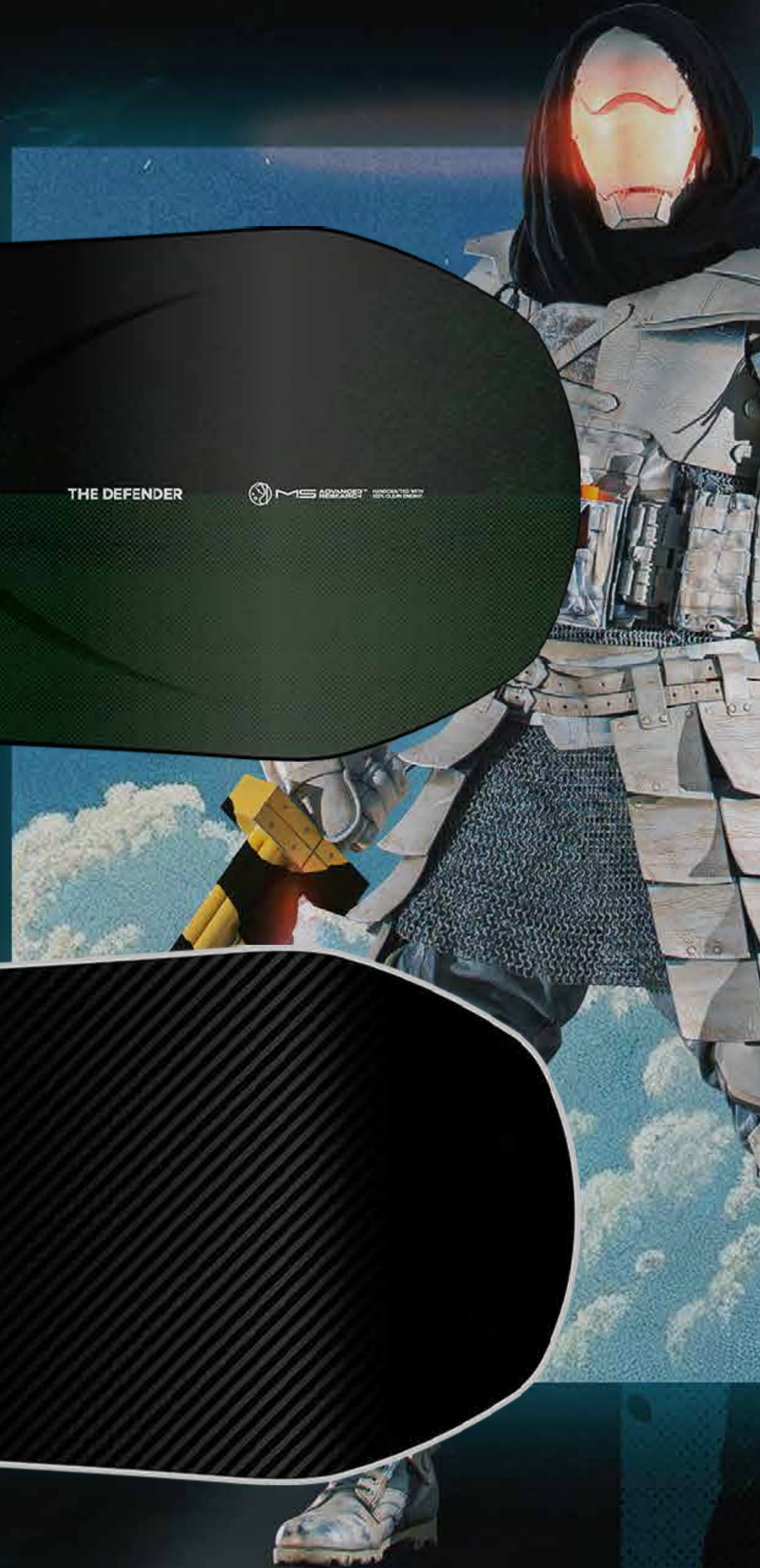
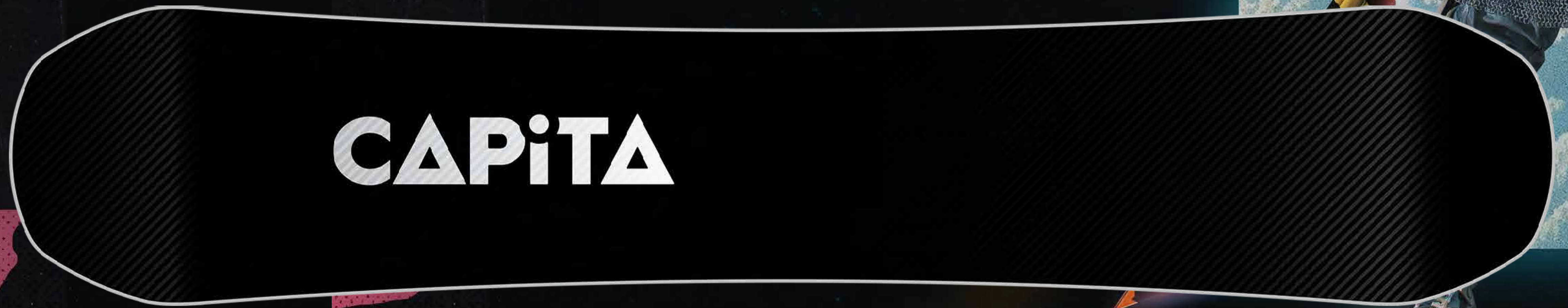

SUPER D.O.A. WIDE

Resort / True Twin / Hybrid Camber



155 W



157 W



159 W



161 W



161 W

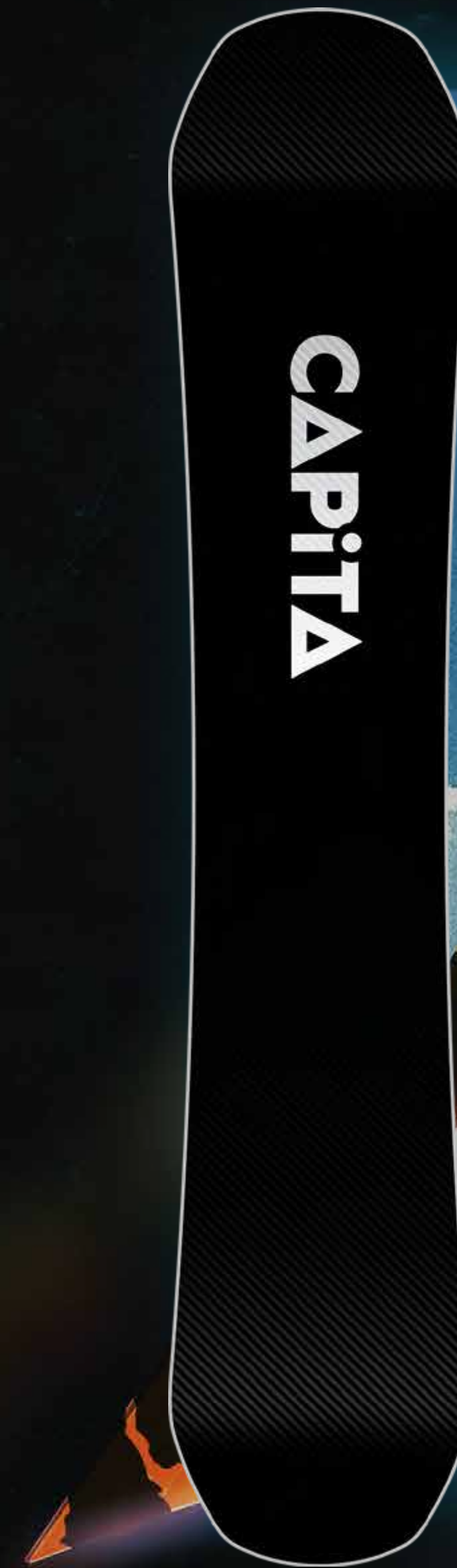

BASE



ALL NEW 3D SHAPES!

SUPER D.O.A.



One of the best snowboards ever designed, enhanced and supercharged.

RIDER TYPE:
Resort

SHAPE:
True Twin

SIDECUT:
Blended Radial

FLEX:
Twin 6

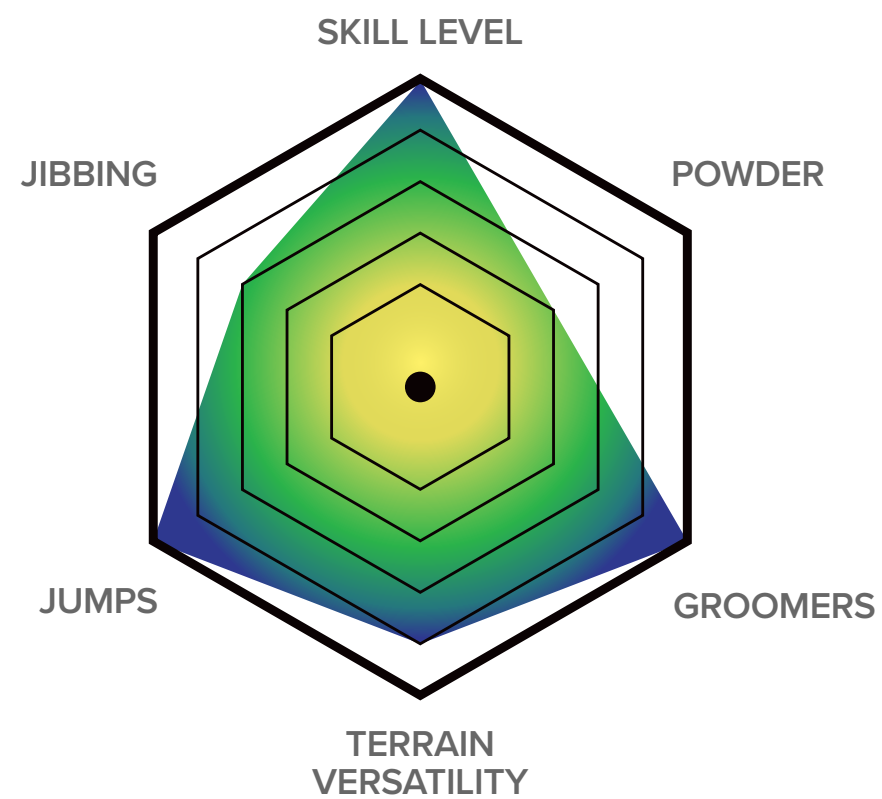

HYBRID CAMBER:
Resort V1 + Flat Kick Tech

Our *RESORT V1 Profile* boards take full advantage of the benefits of traditional camber, zero camber, and reverse camber. This next generation design allows you to get the pop and response of a cambered board with all the predictability and easy turn initiation of zero camber or reverse camber shapes.

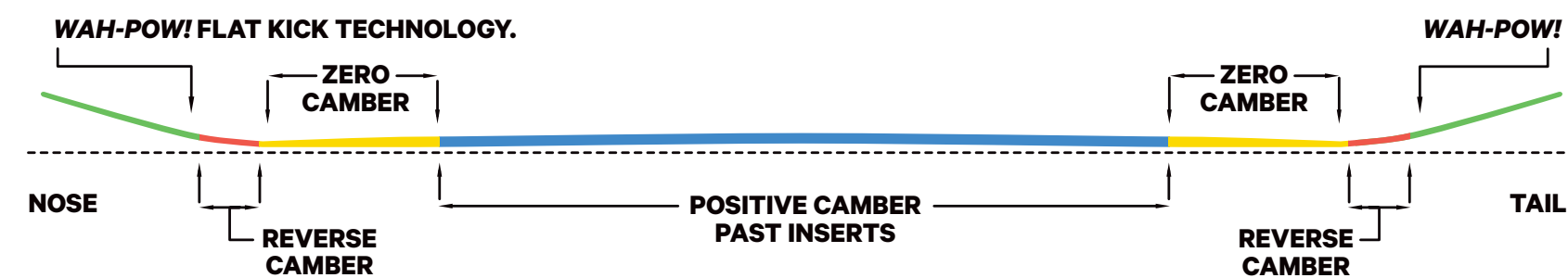

LENGTH	EFFECTIVE EDGE (mm)	WAIST	NOSE / TAIL	SIDECUT	REF. STANCE (cm / inches)	SUGGESTED WEIGHT (lbs / kg)
152	1202	24.8	29.3 / 29.3	7.8	53.3 / 21.0	110-150 / 50-68
154	1218	25.0	29.5 / 29.5	7.9	53.3 / 21.0	120-180 / 54-81
156	1234	25.2	29.7 / 29.7	8.0	55.9 / 22.0	130-190 / 59-86
158	1250	25.4	30.0 / 30.0	8.1	55.9 / 22.0	140-200 / 63-90
160	1266	25.6	30.3 / 30.3	8.2	58.4 / 23.0	160-220 / 72-100
155 W	1226	26.0	30.6 / 30.6	7.9	55.9 / 22.0	130-190 / 59-86
157 W	1242	26.2	30.8 / 30.8	8.0	55.9 / 22.0	140-200 / 63-90
159 W	1258	26.4	31.1 / 31.1	8.1	55.9 / 22.0	150-210 / 68-95
161 W	1274	26.6	31.3 / 31.3	8.2	58.4 / 23.0	160-220 / 72-100
163 W	1290	26.8	31.6 / 31.6	8.3	58.4 / 23.0	170-230 / 77-104

OVERVIEW

Tech Features

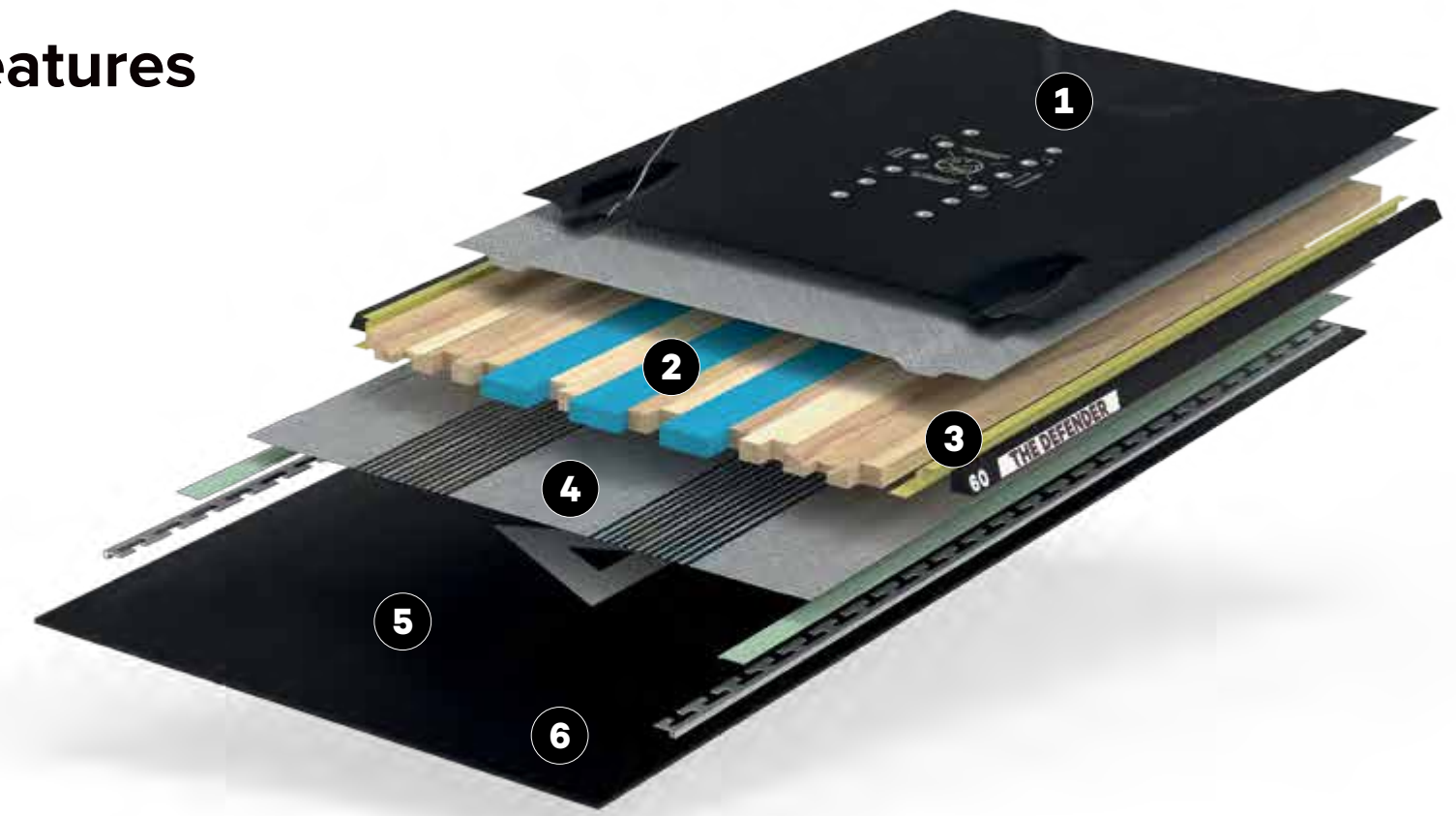

1 TOPSHEET TECH:
MATTE TOPSHEET
• Digital Print
• Metallic Underlay

2 CORE:
NEW!
3D THERMOPOLYMER
STARSHIP CORE™

3 SIDEWALL:
FORTRESS™ ARAMID
BOUND

4 GLASS + RESIN:
HYBRID SUPERCARBON™ HOLYSHEET™
TRI/TRI
MAGIC BEAN™ RESIN

5 BASE:
HYPERDRIVE™ ADV XT
• Die-cut

6 MOONSHOT
OMNI-TUNE™

CORE:

- PET
- SUPERCARBON™
- PAULOWNIA
- POPLAR
- BEECH

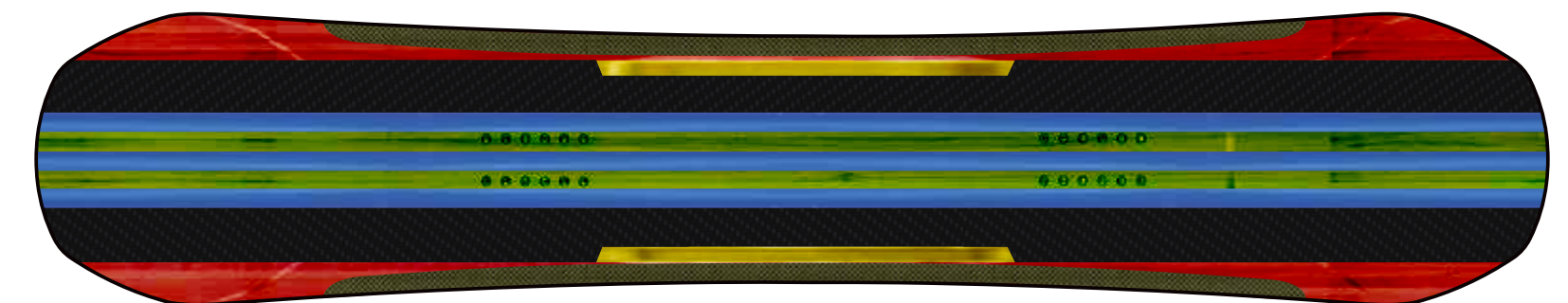

Ultra-premium, lightweight, powerful and fast, the *SUPER D.O.A.* is built with a featherweight Hybrid HolySheet™ Tri/Tri SuperCarbon™ configuration combined with a HyperDrive™ ADV XT base with factory-direct Moonshot Omni-Tune™ taking this already coveted series to new heights. Retaining award-winning perimeter geometry, the *SUPER D.O.A.* features an all-new Thermopolymer Starship Core with re-engineered 3D contouring, further enhancing its performance and versatility.

RESORT

RESORT



AUSTIN VIZZ

ARTHUR LONGO
KEVIN BACKSTROM
MIKE RAV
HENNA IKOLA
KALEAH OPAL
HIMARI TAKAMORI



Engineered for resort riding and all the variables that come with it.

RESORT



SUPER D.O.A.



AERONAUT



D.O.A.



BIRDS OF A FEATHER



OUTERSPACE LIVING



PARADISE

AERONAUT

With Arthur Longo
Resort / Directional / Traditional Camber

Prepare to blast-off with the groundbreaking *Aeronaut* series, a creation born from the visionary mind of the side-hit maestro and Rocket Man extraordinaire, *Arthur Longo*.

This directional, cambered masterpiece is your ticket to conquering all-mountain challenges with blazing speed and jaw-dropping airtime. Redefine the limits of your local resort's terrain as you soar into the realm of Side Hit Euphoria™, courtesy of the *Aeronaut* by *Arthur Longo*.

ARTHUR
LONGO

the creatures of
our dreams



AERONAUT

Resort / Directional / Traditional Camber



the creatures of
our dreams



AERONAUT

Resort / Directional / Traditional Camber



153



155

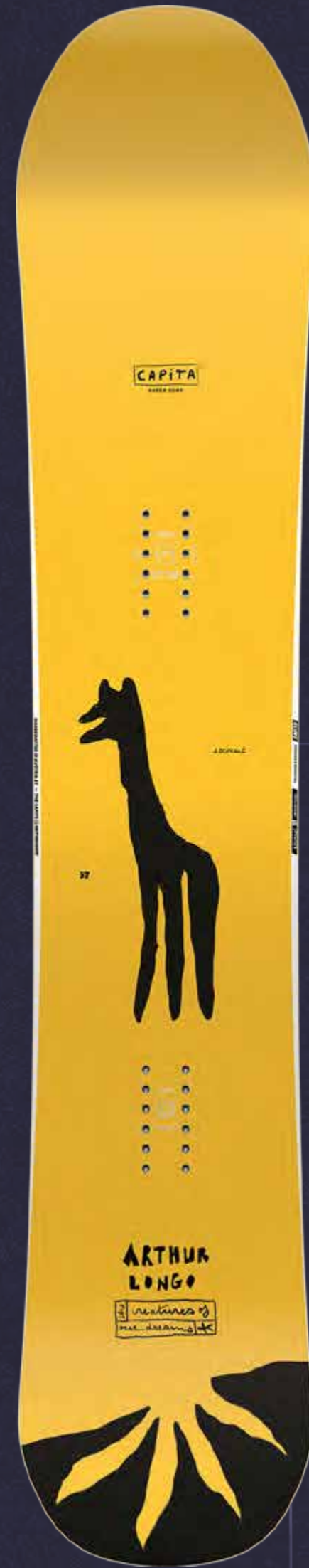

157



159



161



BASE

AERONAUT WIDE

Resort / Directional / Traditional Camber



the creatures of
our dreams



AERONAUT WIDE

Resort / Directional / Traditional Camber



156 W



158 W



160 W



162 W



BASE



AERONAUT



The *Aeronaut* is the resort maximizer, designed by the side hit master himself—*Arthur Longo*.

RIDER TYPE:
Resort / All-Mtn

SHAPE:
Directional
0.8" Setback

SIDECUT:
Progressive

FLEX:
Directional
6

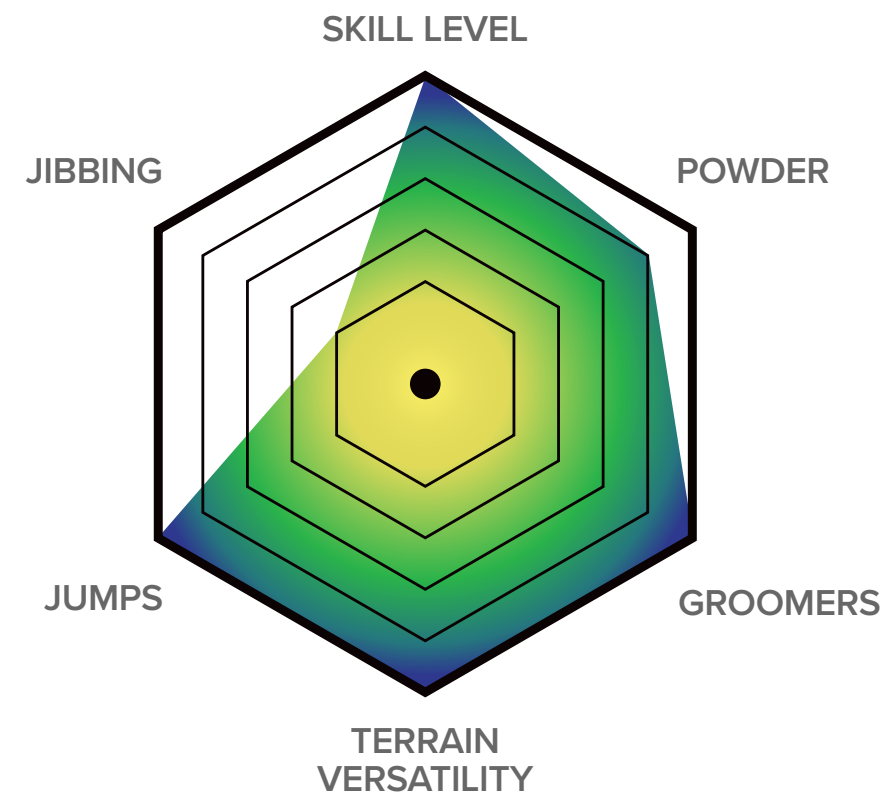

TRADITIONAL CAMBER:
Alpine V3 Directional

The *ALPINE V3* profile has a 7 mm traditional camber that zeros out before the end of the sidecut. The small zero camber sections provide a more controlled ride while retaining the response and power of a cambered board.



LENGTH	EFFECTIVE EDGE (mm)	WAIST	NOSE / TAIL	TAPER	SIDECUT	REF. STANCE (cm / inches)	SUGGESTED WEIGHT (lbs / kg)
153	1200	24.7	29.2 / 28.7	5.0	8.3 / 7.3	53.3 / 21.0	115-175 / 52-79
155	1215	25.0	29.6 / 29.1	5.0	8.4 / 7.4	55.9 / 22.0	125-185 / 56-83
157	1230	25.3	30.0 / 29.5	5.0	8.5 / 7.5	55.9 / 22.0	135-195 / 61-88
159	1245	25.6	30.4 / 29.9	5.0	8.6 / 7.6	55.9 / 22.0	145-205 / 65-92
161	1260	25.9	30.8 / 30.3	5.0	8.7 / 7.7	58.4 / 23.0	160-220 / 72-99
156 W	1222	26.0	30.6 / 30.1	5.0	8.5 / 7.5	55.9 / 22.0	135-195 / 61-88
158 W	1237	26.3	31.0 / 30.5	5.0	8.6 / 7.6	55.9 / 22.0	145-205 / 65-92
160 W	1252	26.6	31.4 / 30.9	5.0	8.7 / 7.7	58.4 / 23.0	160-220 / 72-99
162 W	1267	26.9	31.8 / 31.3	5.0	8.8 / 7.8	58.4 / 23.0	170-230 / 77-104

OVERVIEW

Tech Features

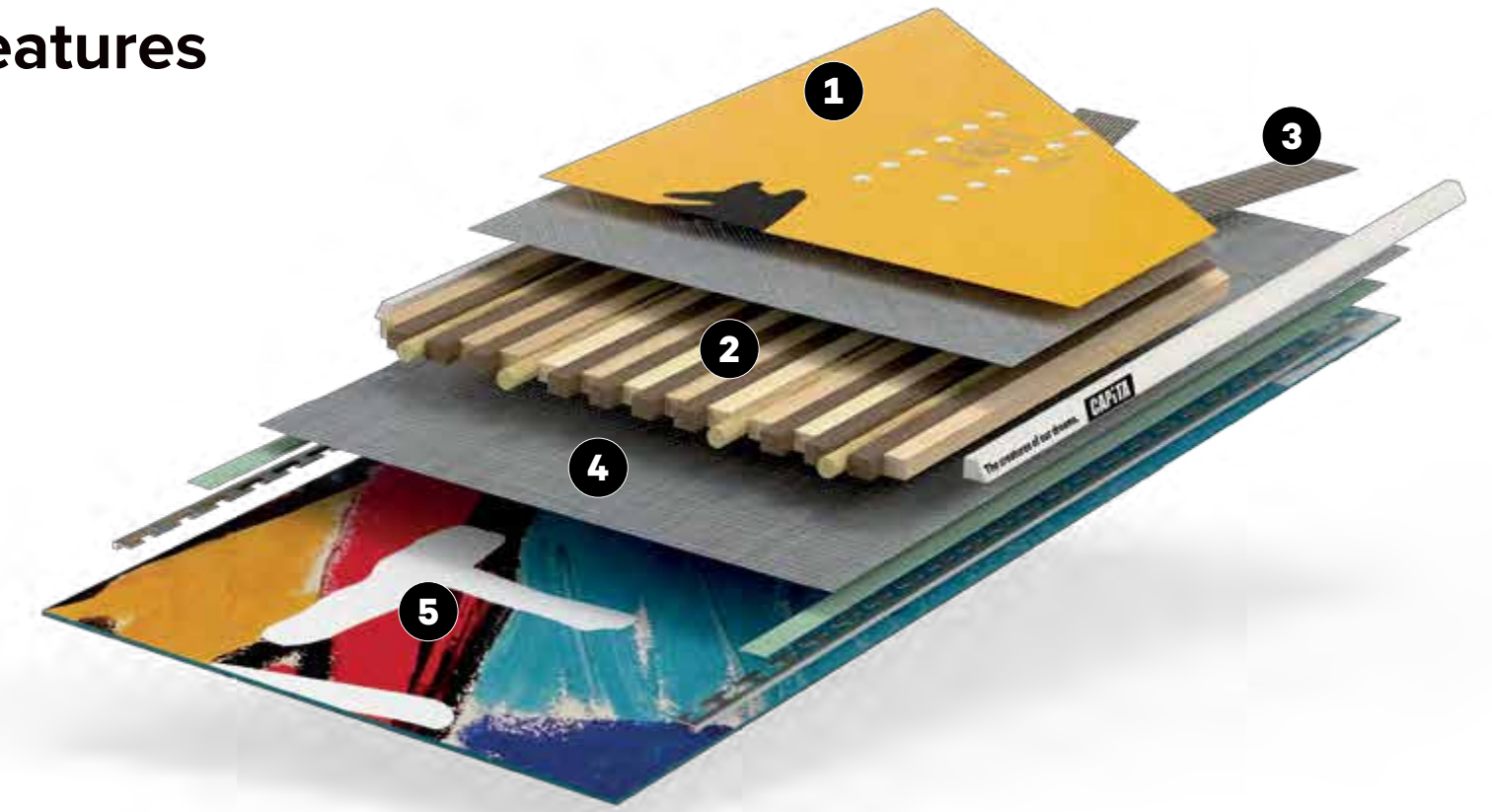

1 TOPSHEET TECH:
PLT Technology
• Metallic Screen
+ Gloss/Matte Print

2 CORE:
PANDA HOVER CORE™

3 ADDITIVES:
3 x 25 mm CARBONFLAX™ AMPLIFIER

4 GLASS + RESIN:
HOLYSHEET™ TRI/BI
MAGIC BEAN™ RESIN

5 BASE:
HYPERDRIVE™ ADV XT
• Sublimation

CORE:
■ CARBONFLAX™
■ BAMBOO
■ PAULOWNIA
■ POPLAR



Designed to charge the resort and sidecountry hits like Arthur, this series will blast you into space with a high speed, super tough HyperDrive™ ADV XT base combines a lightweight and extremely durable Panda Hover Core™ with Carbon-Flax™ Amplifiers for tons of pop. The high-speed performance of the *Aeronaut* was upgraded in 2025 with a tougher, HyperDrive™ ADV XT base.

D.O.A.

Resort / True Twin / Hybrid Camber

The *Defenders of Awesome* is so mind-bogglingly award-winning that if it entered the intergalactic snowboarding Olympics, it would effortlessly bag a gold in every parallel dimension. It's not just our top-selling snowboard; it's the snowboard that doubles as a sentient being, offering sage advice on the meaning of snowboarding and the universe.



D.O.A. Resort / True Twin / Hybrid Camber



D.O.A.

Resort / True Twin / Hybrid Camber



148



150



152



154



156



158



160



162



164



BASE

D.O.A.

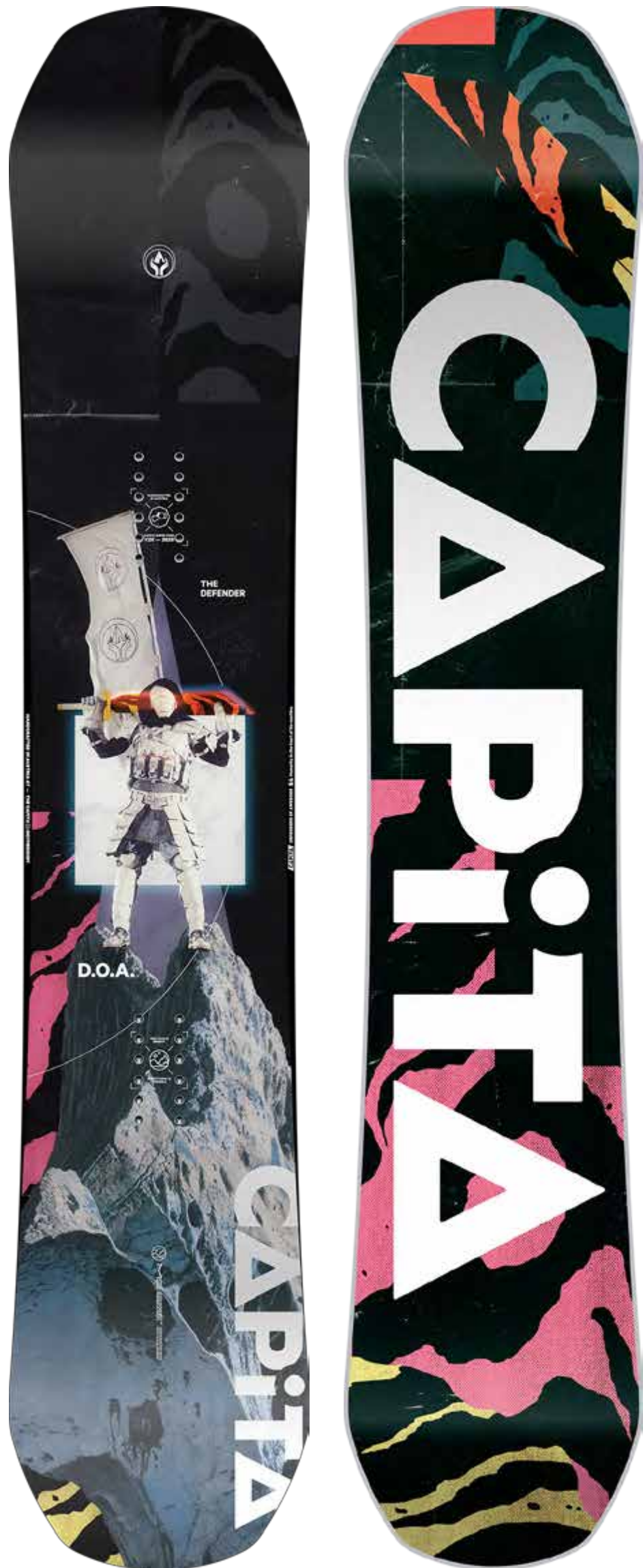

The Icon. One of the most famous snowboards of all time.

RIDER TYPE:
Resort

SHAPE:
True Twin

SIDECUT:
Blended Radial

FLEX:
Twin 5.5

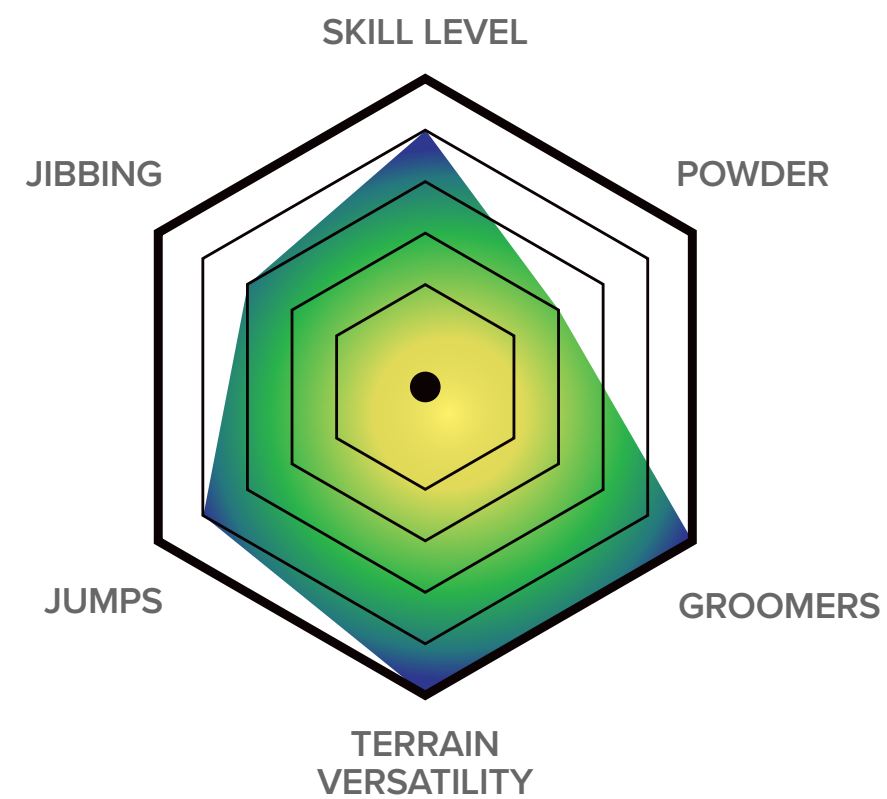

HYBRID CAMBER:
Resort V1 + Flat Kick Tech

Our *RESORT V1 Profile* boards take full advantage of the benefits of traditional camber, zero camber, and reverse camber. This next generation design allows you to get the pop and response of a cambered board with all the predictability and easy turn initiation of zero camber or reverse camber shapes.

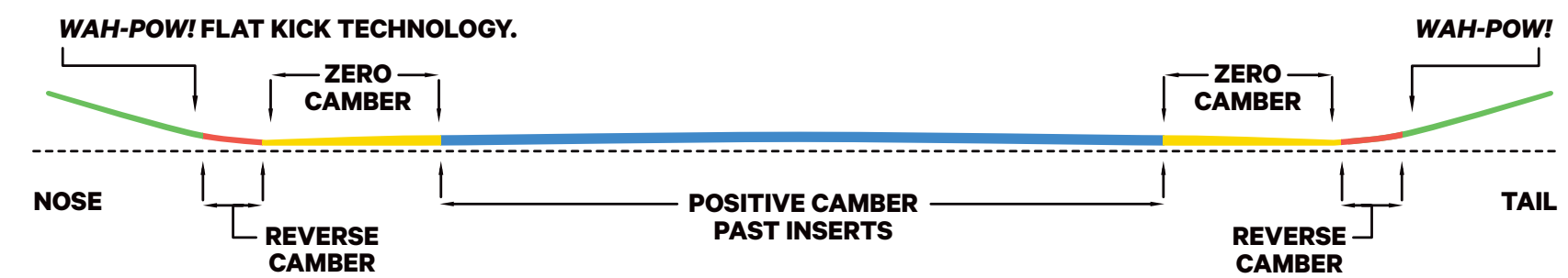

LENGTH	EFFECTIVE EDGE (mm)	WAIST	NOSE / TAIL	SIDECUT	REF. STANCE (cm / inches)	SUGGESTED WEIGHT (lbs / kg)
148	1176	24.4	28.7 / 28.7	7.6	50.8 / 20.0	90-150 / 40-68
150	1191	24.6	29.0 / 29.0	7.7	53.3 / 21.0	100-150 / 45-68
152	1207	24.8	29.2 / 29.2	7.8	53.3 / 21.0	110-150 / 50-68
154	1222	25.0	29.5 / 29.5	7.9	53.3 / 21.0	120-180 / 54-81
156	1233	25.2	29.8 / 29.8	8.0	55.9 / 22.0	130-190 / 59-86
158	1256	25.4	30.0 / 30.0	8.1	55.9 / 22.0	140-200 / 63-90
160	1270	25.7	30.4 / 30.4	8.2	58.4 / 23.0	160-220 / 72-100
162	1287	25.9	30.6 / 30.6	8.3	58.4 / 23.0	180-240 / 82-110
164	1301	26.1	30.9 / 30.9	8.4	58.4 / 23.0	190-245 / 86-111

OVERVIEW

Tech Features



1 TOPSHEET TECH:
PLT Technology
• Digital + Screen Print
• Metallic Underlay

2 CORE:
P2 SUPERLIGHT™

3 GLASS + RESIN:
HYBRID CARBON HOLYSHEET™
BI/BI
MAGIC BEAN™ RESIN

4 BASE:
QUANTUM DRIVE™
• Sublimation

CORE:
■ CARBON
■ PAULOWNIA
■ POPLAR



The *D.O.A.* achieves its iconic and award-winning performance through a lightweight, durable, and poppy P2 Superlight™ Core. The *D.O.A.*'s Hybrid Holy-Sheet™ is directly interwoven with Carbon Boosters for a precise, featherweight construction.

D.O.A. WIDE

Resort / True Twin / Hybrid Camber



D.O.A. WIDE

Resort / True Twin / Hybrid Camber



151 W



153 W



155 W



157 W



159 W



161 W



163 W



BASE

D.O.A. WIDE



The Icon. One of the most famous snowboards of all time.

RIDER TYPE:
Resort

SHAPE:
True Twin

SIDECUT:
Blended Radial

FLEX:
Twin 5.5

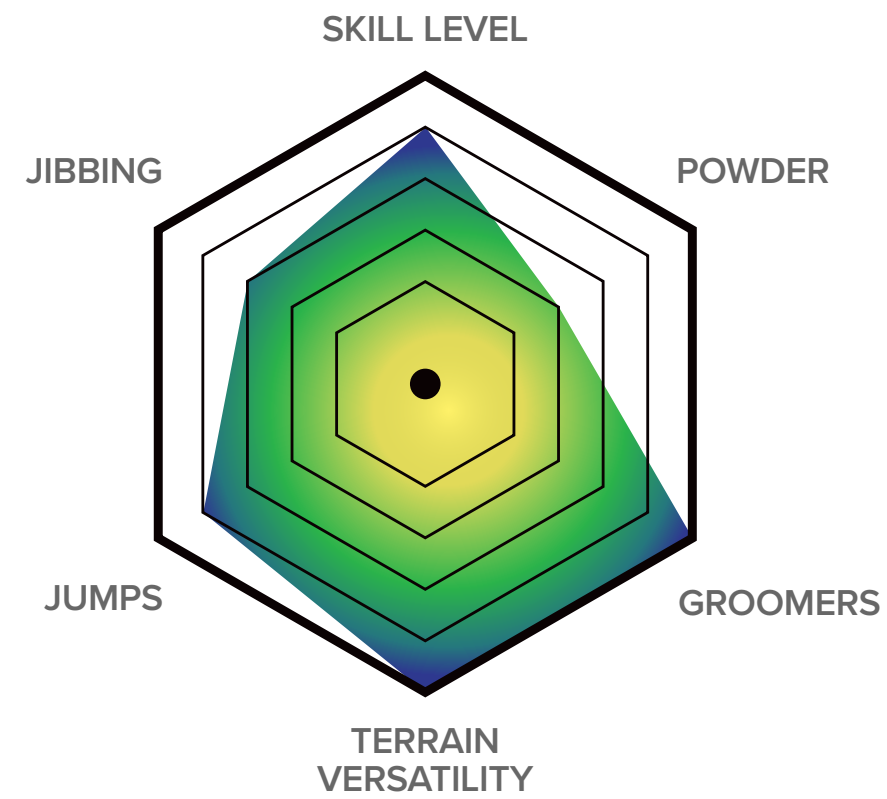

HYBRID CAMBER:
Resort V1 + Flat Kick Tech

Our *RESORT V1 Profile* boards take full advantage of the benefits of traditional camber, zero camber, and reverse camber. This next generation design allows you to get the pop and response of a cambered board with all the predictability and easy turn initiation of zero camber or reverse camber shapes.

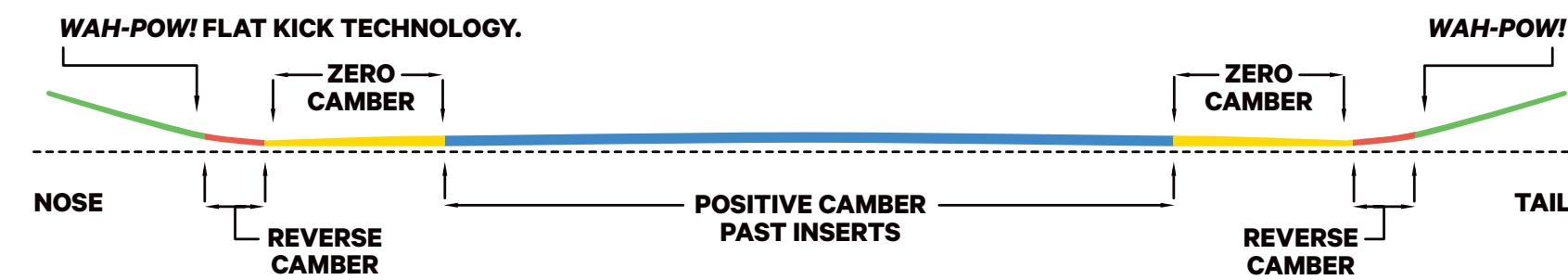

LENGTH	EFFECTIVE EDGE (mm)	WAIST	NOSE / TAIL	SIDECUT	REF. STANCE (cm / inches)	SUGGESTED WEIGHT (lbs / kg)
151 W	1170	25.5	29.7 / 29.7	7.9	53.3 / 21.0	110-150 / 49-68
153 W	1185	25.6	29.9 / 29.9	8.0	53.3 / 21.0	120-180 / 54-81
155 W	1205	25.8	30.2 / 30.2	8.1	55.9 / 22.0	130-190 / 59-86
157 W	1239	26.0	30.5 / 30.5	8.1	55.9 / 22.0	140-200 / 63-90
159 W	1259	26.1	30.7 / 30.7	8.2	55.9 / 22.0	150-210 / 68-95
161 W	1280	26.2	30.9 / 30.9	8.3	58.4 / 23.0	160-220 / 73-100
163 W	1297	26.3	31.1 / 31.1	8.4	58.4 / 23.0	170-230 / 77-104

OVERVIEW

Tech Features



1
TOPSHEET TECH:
PLT Technology
• Digital + Screen Print
• Metallic Underlay

2
CORE:
P2 SUPERLIGHT™

3
GLASS + RESIN:
HYBRID CARBON HOLYSHEET™
BI/BI
MAGIC BEAN™ RESIN

4
BASE:
QUANTUM DRIVE™
• Sublimation

CORE:
■ CARBON
■ PAULOWNIA
■ POPLAR



The *D.O.A.* achieves its iconic and award-winning performance through a v lightweight, durable, and poppy P2 Superlight™ Core. The *D.O.A.*'s Hybrid HolySheet™ is directly interwoven with Carbon Boosters for a precise, feather-weight construction.

BIRDS OF A FEATHER

Women's / Resort / True Twin / Hybrid Camber

The *Birds of a Feather* is a women's specific technical adaptation of the best-selling *D.O.A.* series.

It delivers the legendary performance of one of the world's most coveted snowboards, refined with flex patterns and geometric sizing to cater to women's specific riding preferences.

The *Birds of a Feather* is a versatile, all-encompassing snowboard, ready to revolutionize your snowboarding experience and empower you to ride anywhere and conquer anything.



BIRDS OF A FEATHER

Women's / Resort / True Twin / Hybrid Camber



BIRDS OF A FEATHER WIDE

Women's / Resort / True Twin / Hybrid Camber



BIRDS OF A FEATHER



Legendary performance for the resort riding looking for an award-winning experience to take their riding to new heights.

RIDER TYPE:
Resort

SHAPE:
True Twin

SIDECUT:
Blended Radial

FLEX:
Twin 5.5

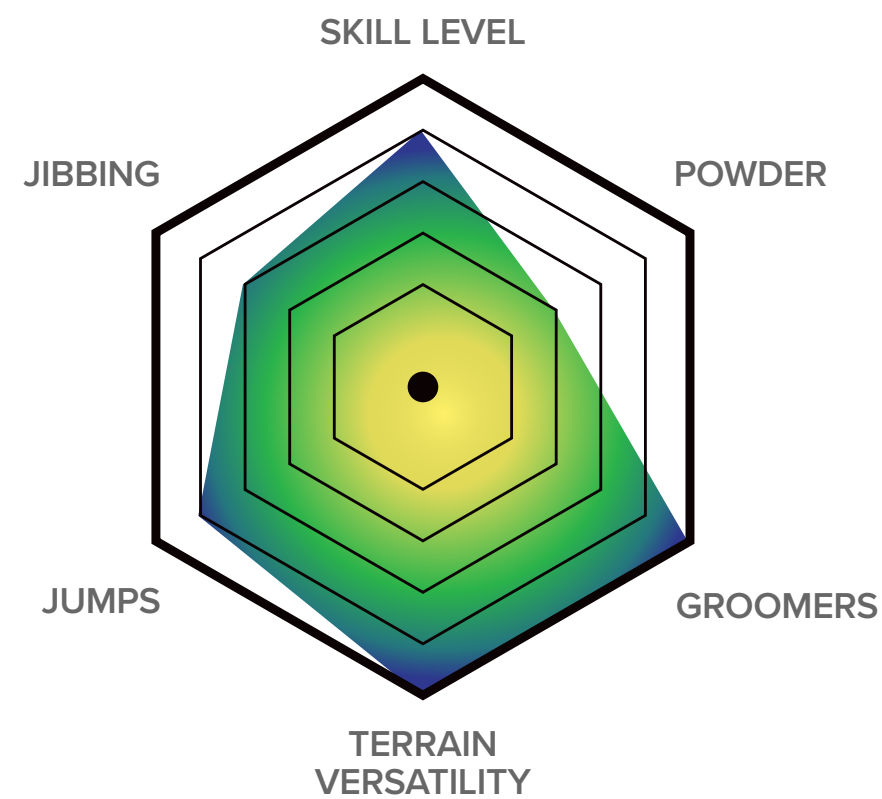

HYBRID CAMBER:
Resort V1 + Flat Kick Tech

Our *RESORT V1 Profile* boards take full advantage of the benefits of traditional camber, zero camber, and reverse camber. This next generation design allows you to get the pop and response of a cambered board with all the predictability and easy turn initiation of zero camber or reverse camber shapes.

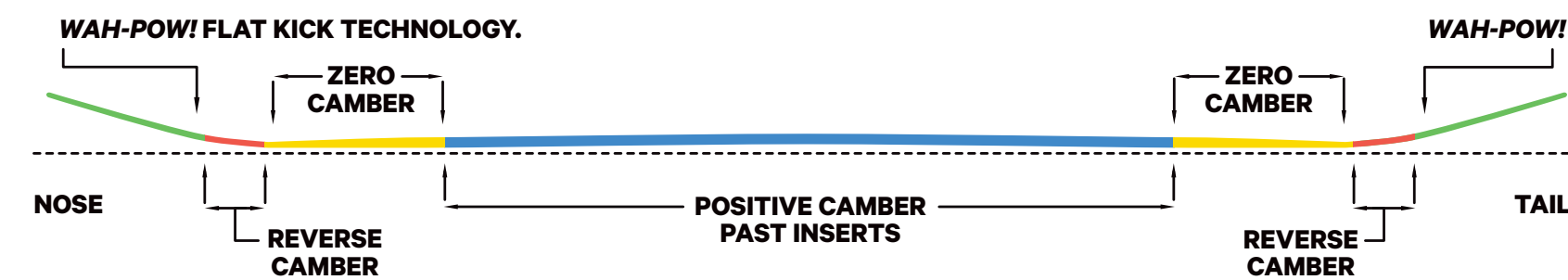

LENGTH	EFFECTIVE EDGE (mm)	WAIST	NOSE / TAIL	SIDECUT	REF. STANCE (cm / inches)	SUGGESTED WEIGHT (lbs / kg)
NEW! 138	1084	22.3	26.7 / 26.7	6.4	45.7 / 18.0	80-130 / 36-58
140	1103	22.6	27.0 / 27.0	6.6	48.3 / 19.0	85-135 / 38-61
142	1118	22.9	27.3 / 27.3	6.8	48.3 / 19.0	90-140 / 41-64
144	1136	23.2	27.6 / 27.6	7.0	48.3 / 19.0	95-145 / 43-66
146	1151	23.5	27.9 / 27.9	7.2	50.8 / 20.0	100-150 / 45-68
148	1170	23.8	28.2 / 28.2	7.4	50.8 / 20.0	105-155 / 47-70
150	1186	24.1	28.5 / 28.5	7.6	53.3 / 21.0	110-160 / 49-73
152	1202	24.4	28.8 / 28.8	7.8	53.3 / 21.0	115-165 / 52-75
154	1218	24.7	29.2 / 29.2	8.0	53.3 / 21.0	120-170 / 54-77
148 W	1176	24.4	28.7 / 28.7	7.6	50.8 / 20.0	110-160 / 49-73
150 W	1191	24.6	28.9 / 28.9	7.7	53.3 / 21.0	115-165 / 52-75
152 W	1207	24.8	29.2 / 29.2	7.8	53.3 / 21.0	120-175 / 54-80
154 W	1222	25.0	29.5 / 29.5	7.9	53.3 / 21.0	125-180 / 56-81

OVERVIEW

Tech Features

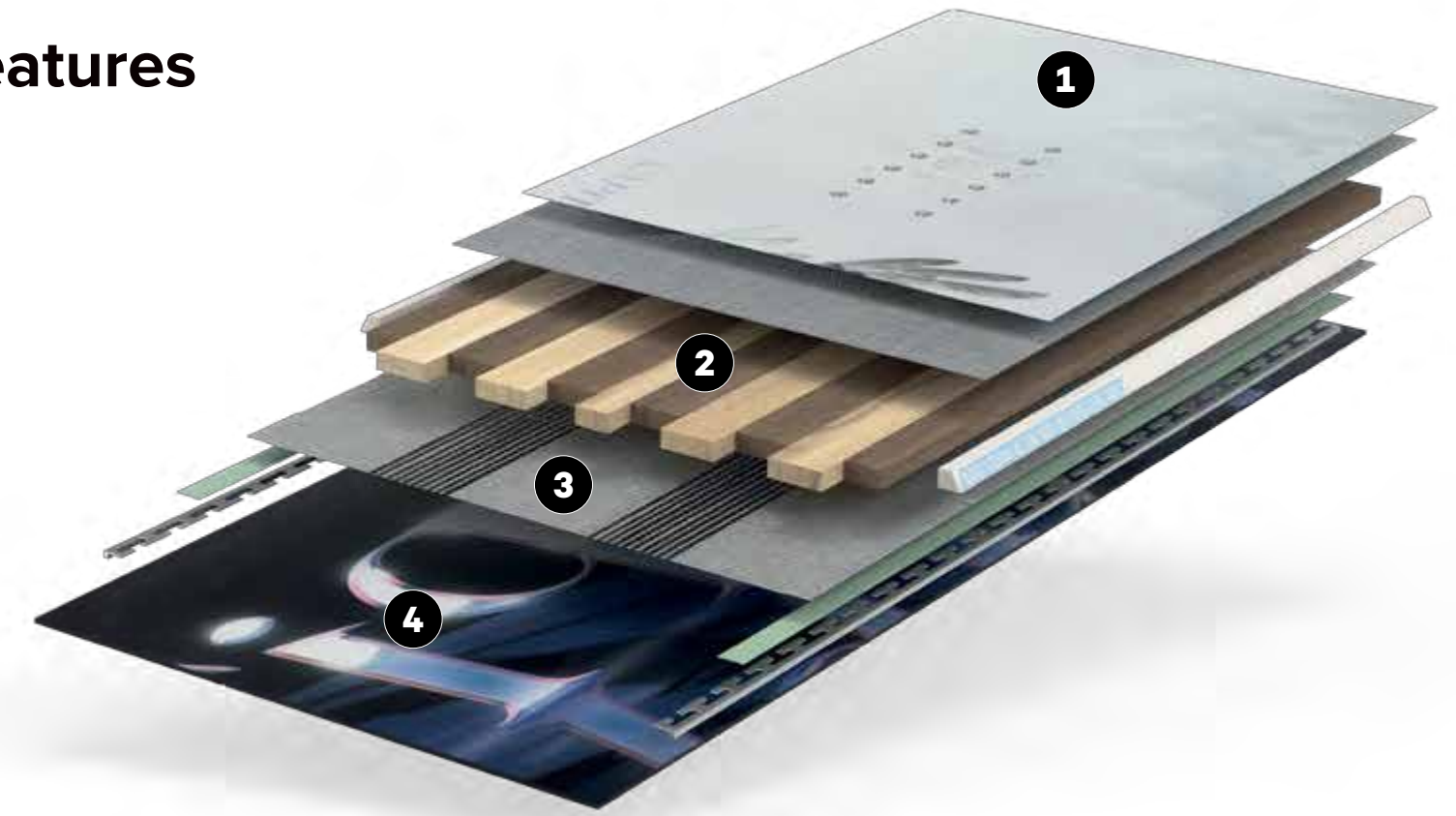

1 TOPSHEET TECH:
PLT Technology
• Digital + Screen Print
• Metallic Underlay

2 CORE:
P2 SUPERLIGHT™

3 GLASS + RESIN:
HYBRID CARBON HOLYSHEET™
BI/BI
MAGIC BEAN™ RESIN

4 BASE:
QUANTUM DRIVE™
• Sublimation

CORE:
■ CARBON
■ PAULOWNIA
■ POPLAR



The *Birds of a Feather* achieves award-winning performance through a light-weight, durable, and poppy P2 Superlight™ Core. The *Bird's* Hybrid HolySheet™ is directly interwoven with Carbon Boosters for a precise, featherweight construction.

OUTERSPACE LIVING

Resort / Directional Twin / Hybrid Camber

The *Outerspace Living* features a true-twin free-style shape blended with an all-terrain camber profile built for freeriding.

Inspired by the award-winning *Mercury* series, positive camber lies underfoot for power retention while an elevated nose and tail help the board swim through variable conditions.

Do you want to crush laps through the park after the powder is tracked out? If so, then this is the board for you.



OUTERSPACE LIVING

Resort / Directional Twin / Hybrid Camber



OUTERSPACE LIVING WIDE

Resort / Directional Twin / Hybrid Camber



OUTERSPACE LIVING

Lightweight and versatile, this board shines for the intermediate all-terrain freerider.

RIDER TYPE:
Resort

SHAPE:
Directional Twin
0.5" Set Back

SIDECUT:
Radial

FLEX:
Twin
5

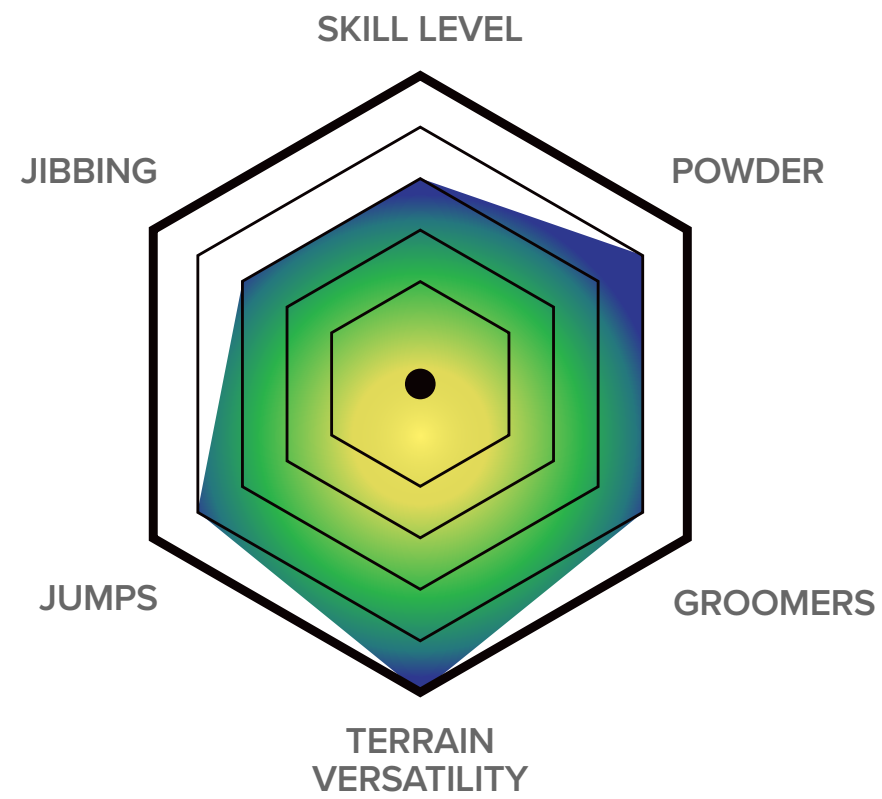

HYBRID CAMBER:
Resort V3

The *RESORT V3 Profile* provides the best of both worlds. It has a raised camber platform through the inserts to retain high-speed edge hold through variable terrain, elevated contact points to land and float in powder, and traditional tip and tail arcs for smoother transitions.



LENGTH	EFFECTIVE EDGE (mm)	WAIST	NOSE / TAIL	SIDECUT	REF. STANCE (cm / inches)	SUGGESTED WEIGHT (lbs / kg)
148	1120	24.4	28.2 / 28.2	7.5	50.8 / 20.0	80-140 / 36-63
150	1136	24.6	28.5 / 28.5	7.6	53.3 / 21.0	100-150 / 45-68
152	1152	24.8	28.8 / 28.8	7.7	53.3 / 21.0	110-160 / 50-72
154	1168	25.0	29.1 / 29.1	7.8	53.3 / 21.0	120-180 / 54-81
156	1184	25.2	29.4 / 29.4	7.9	55.9 / 22.0	130-190 / 59-86
158	1200	25.4	29.7 / 29.7	8.0	55.9 / 22.0	140-200 / 63-90
160	1216	25.6	30.0 / 30.0	8.1	58.4 / 23.0	150-210 / 68-95
155 W	1180	26.0	30.3 / 30.3	7.8	55.9 / 22.0	125-185 / 57-84
157 W	1196	26.2	30.6 / 30.6	7.9	55.9 / 22.0	135-195 / 61-88
159 W	1212	26.4	30.9 / 30.9	8.0	55.9 / 22.0	145-210 / 66-95
161 W	1228	26.6	31.2 / 31.2	8.1	58.4 / 23.0	155-225 / 70-102

OVERVIEW

Tech Features

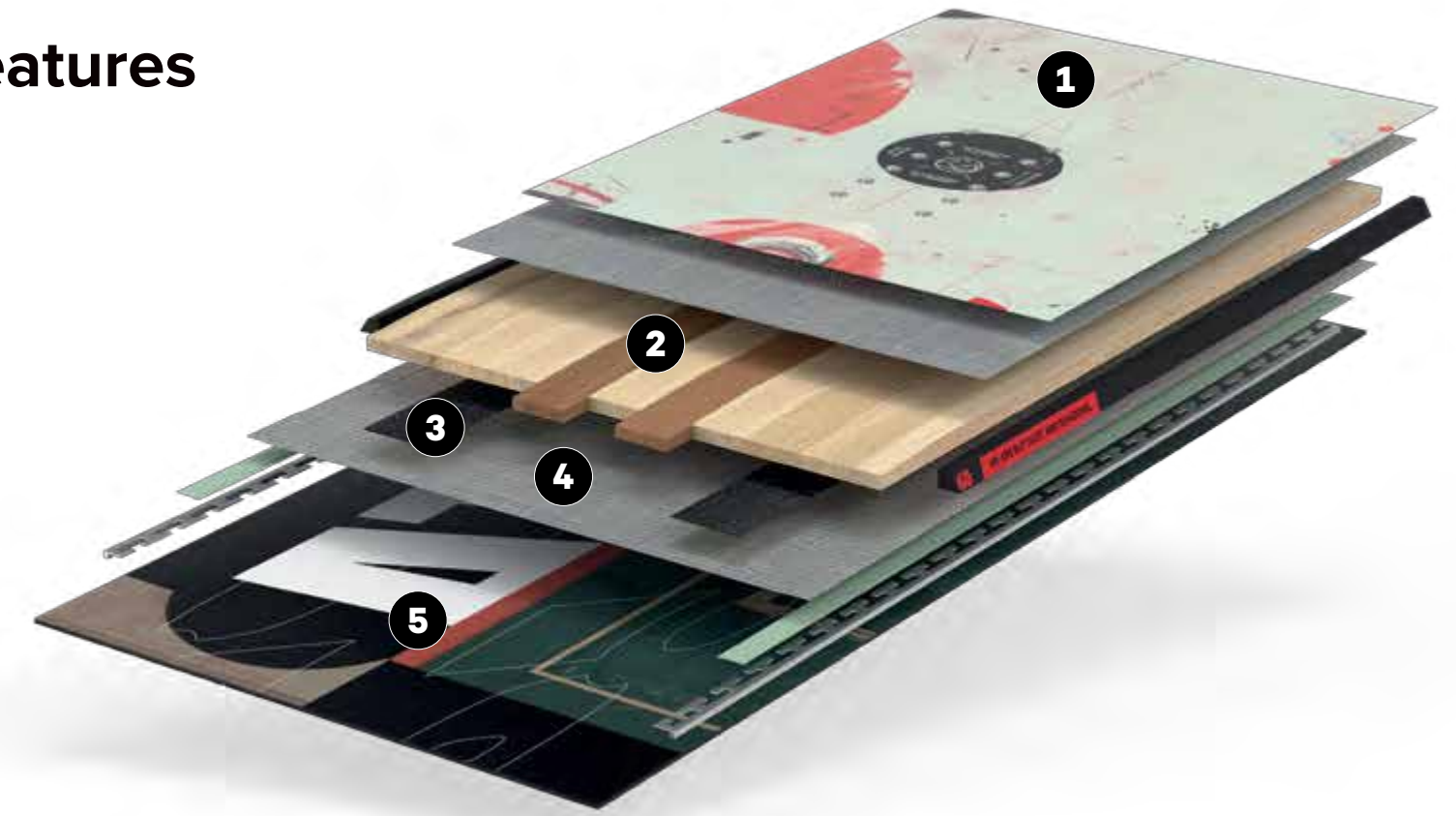

1 TOPSHEET TECH:
PLT Technology
• Digital + Screen Print
• Metallic Underlay

2 CORE:
MULTIZONE DUAL CORE™

3 ADDITIVE:
NEW!
4 x 30 mm
CARBON BOOSTERS

4 GLASS + RESIN:
SPECIAL BLEND FIBERGLASS MAGIC BEAN™ RESIN

5 BASE:
SUPERDRIVE™ ADV
• Digital Print

CORE:
■ CARBON
■ BEECH
■ POPLAR



The *Outerspace Living* delivers unmatched versatility in a lightweight package with the Multizone Dual Core™ at its heart. The *Outerspace Living* solidifies its place as the go-to series for intermediate resort riders looking to boost their riding to the next level.

PARADISE

Women's / Resort / Directional Twin / Hybrid Camber

These perfectly balanced all-terrain freeride boards are stable and supportive – yet forgiving and easy to ride at the same time.

Featuring camber underfoot for controlled turns and a rockered nose and tail that floats in powder, the *Paradise* is the perfect board to cruise side-country powder in the morning and laps through the park in the afternoon.



PARADISE

Women's / Resort / Directional Twin / Hybrid

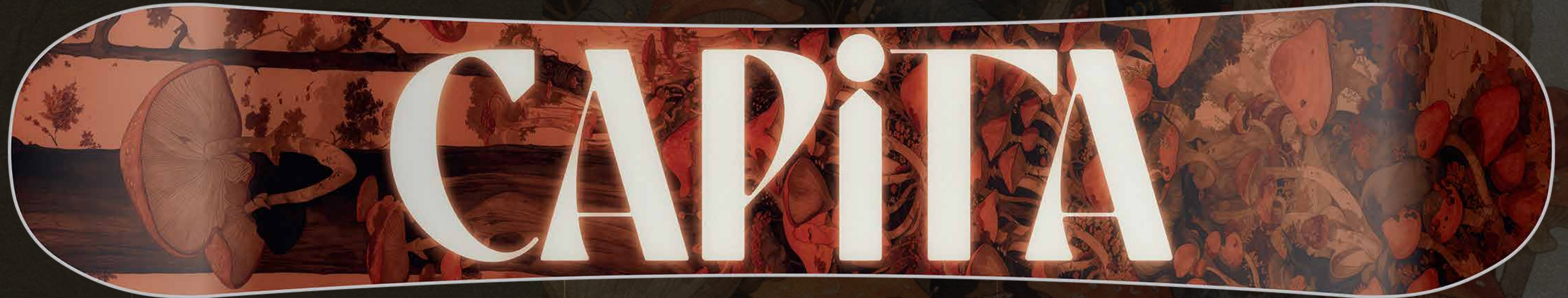

PARADISE WIDE

Women's / Resort / Directional Twin / Hybrid



PARADISE



Lightweight and versatile, this board shines for the intermediate all-terrain freerider.

RIDER TYPE:
Resort

SHAPE:
Directional Twin
0.5" Set Back

SIDECUT:
Radial

FLEX:
Twin
5

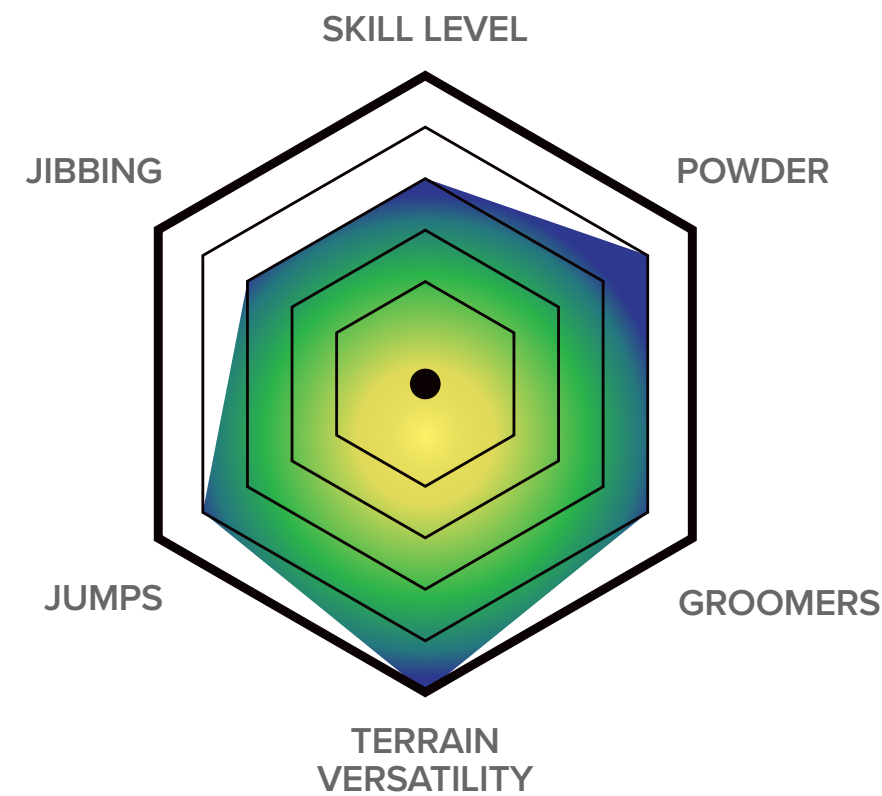

HYBRID CAMBER:
Resort V3

The *RESORT V3 Profile* provides the best of both worlds. It has a raised camber platform through the inserts to retain high-speed edge hold through variable terrain, elevated contact points to land and float in powder, and traditional tip and tail arcs for smoother transitions.

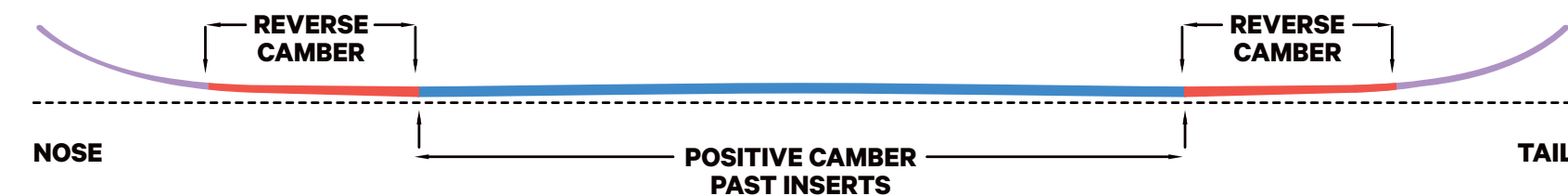

LENGTH	EFFECTIVE EDGE (mm)	WAIST	NOSE / TAIL	SIDECUT	REF. STANCE (cm / inches)	SUGGESTED WEIGHT (lbs / kg)
139	1056	23.0	26.7 / 26.7	7.0	45.7 / 18.0	80-130 / 36-59
141	1072	23.2	27.0 / 27.0	7.1	48.3 / 19.0	85-135 / 38-61
143	1088	23.4	27.3 / 27.3	7.2	48.3 / 19.0	90-140 / 41-64
145	1104	23.6	27.6 / 27.6	7.3	50.8 / 20.0	95-145 / 43-65
147	1120	23.8	27.9 / 27.9	7.4	50.8 / 20.0	100-150 / 45-68
149	1136	24.0	28.2 / 28.2	7.5	50.8 / 20.0	110-160 / 49-73
151	1152	24.2	28.5 / 28.5	7.6	53.3 / 21.0	115-170 / 52-77
148 W	1120	24.4	28.2 / 28.2	7.5	50.8 / 20.0	100-150 / 45-68
150 W	1136	24.6	28.5 / 28.5	7.6	53.3 / 21.0	110-160 / 49-72
152 W	1152	24.8	28.8 / 28.8	7.7	53.3 / 21.0	115-175 / 52-79

OVERVIEW

Tech Features

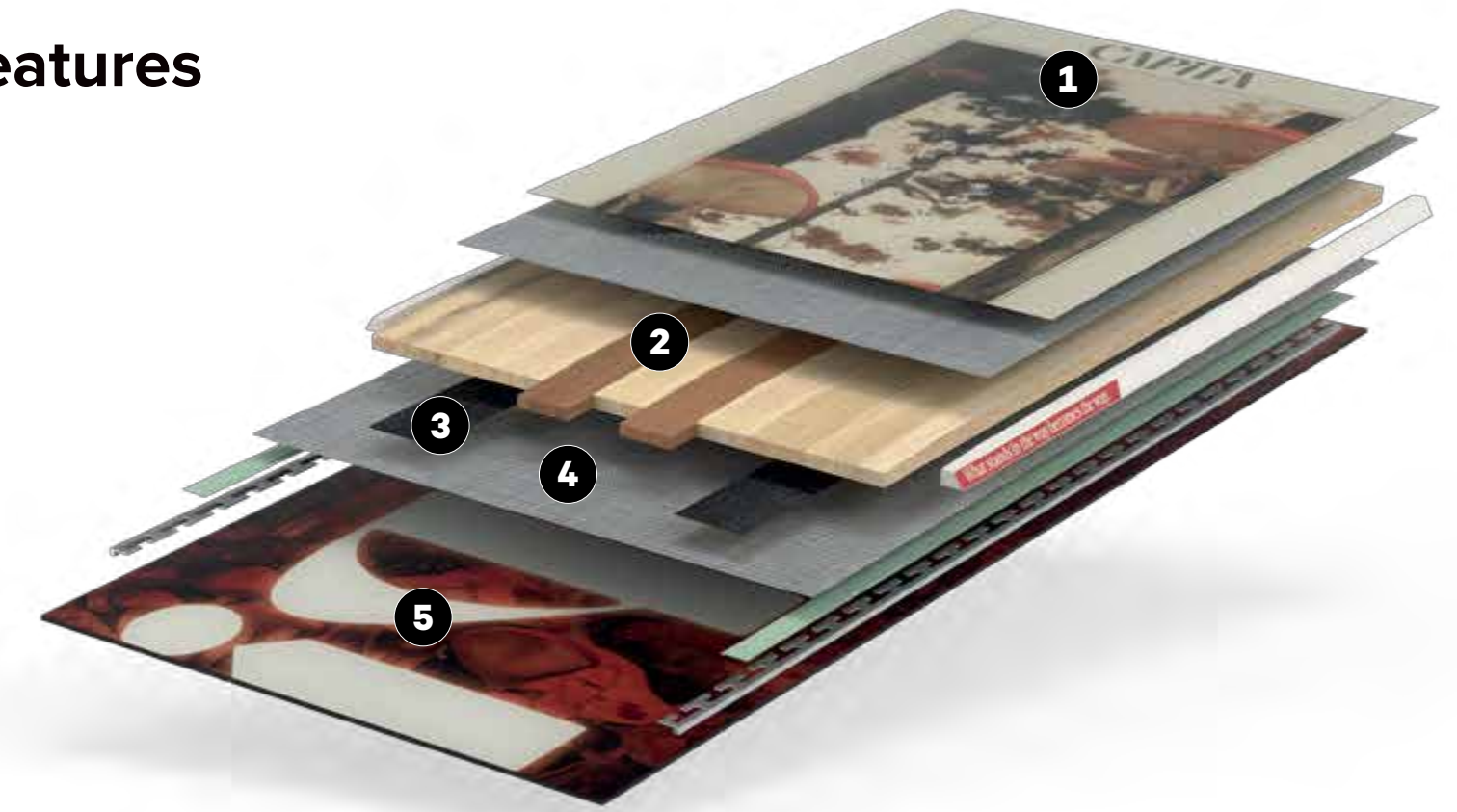

- 1** TOPSHEET TECH: **PLT Technology**
• Digital + Screen Print
• Metallic Underlay
- 2** CORE: **MULTIZONE DUAL CORE™**
- 3** ADDITIVE: **NEW!**
4 x 30 mm **CARBON BOOSTERS**

- 4** GLASS + RESIN: **SPECIAL BLEND FIBERGLASS MAGIC BEAN™ RESIN**
- 5** BASE: **SUPERDRIVE™ ADV**
• Digital Print

- CORE:
- CARBON
 - BEECH
 - POPLAR



The *Paradise* delivers unmatched versatility in a lightweight package with the Multizone Dual Core™ at its heart.

The *Paradise* solidifies its place as the go-to series for intermediate resort riders looking to boost their riding to the next level.

FREESTYLE



MILES FALLON



- AUSTIN VIZZ
- MIKE RAV
- SCOTT STEVENS
- BENNY MILAM

Engineered for transitions, rails and parks.

FREESTYLE



INDOOR SURVIVAL



ULTRAFEAR



DARK HORSE



PATHFINDER



SPACE METAL FANTASY

INDOOR SURVIVAL

Park + Resort / True Twin / Traditional Camber

The *Indoor Survival* is a standout performer both at the resort and in the park.

It achieves this through its innovative Meta Core™ and Titanal Centerline Booster, which provide exceptional underfoot responsiveness while maintaining a lightweight construction.

Furthermore, the *Indoor Survival* features the New Age Twin shape with Death Grip™, allowing you to maximize its carving prowess, enhancing your experience on the slopes.



INDOOR SURVIVAL

Park + Resort / True Twin / Traditional Camber



INDOOR SURVIVAL WIDE

Park + Resort / True Twin / Traditional Camber



INDOOR SURVIVAL



The poppy and quick-turning freestyle board that can do it all.

RIDER TYPE:
Park / Resort

SHAPE:
True Twin

SIDECUT:
**New Age Radial
Death Grip™**

FLEX:
**Twin
4.5**

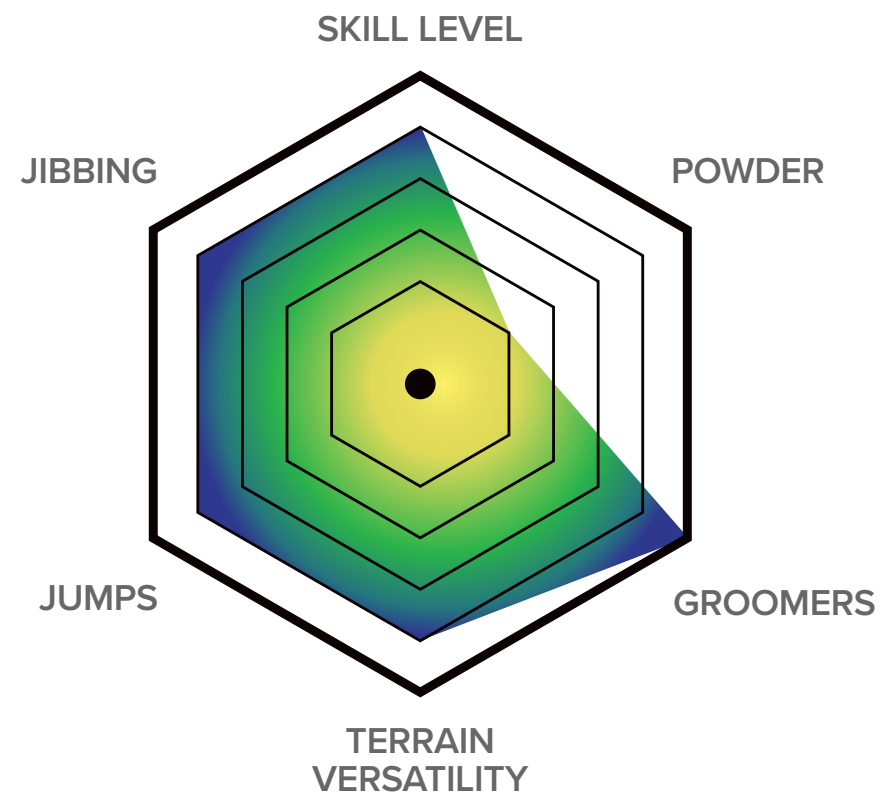

TRADITIONAL CAMBER:
Park V1 + Flat Kick Tech

The *PARK V1* camber configuration zeros out a traditional camber approach 4 cm before the end of the sidecut transitioning into a Flat Kick nose and tail.

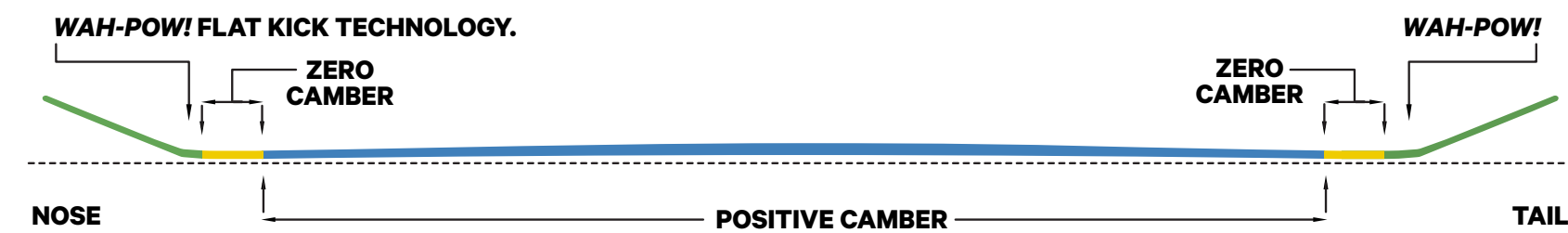

LENGTH	EFFECTIVE EDGE (mm)	WAIST	NOSE / TAIL	SIDECUT	REF. STANCE (cm / inches)	SUGGESTED WEIGHT (lbs / kg)
150	1165	24.9	29.2 / 29.2	7.7 / -1.5 / 7.7	50.8 / 20.0	100-150 / 45-68
152	1180	25.0	29.6 / 29.6	7.7 / -1.5 / 7.7	53.3 / 21.0	110-160 / 50-72
154	1196	25.5	30.0 / 30.0	7.9 / -1.5 / 7.9	53.3 / 21.0	120-180 / 54-81
156	1211	25.8	30.4 / 30.4	7.9 / -1.5 / 7.9	55.9 / 22.0	130-190 / 59-86
158	1227	26.0	30.8 / 30.8	8.0 / -1.5 / 8.0	55.9 / 22.0	140-200 / 63-90
160	1242	26.2	31.2 / 31.2	8.1 / -1.5 / 8.1	58.4 / 23.0	150-210 / 68-95
155 W	1203	26.1	30.9 / 30.9	7.9 / -1.5 / 7.9	55.9 / 22.0	130-190 / 59-86
158 W	1227	26.5	31.3 / 31.3	8.0 / -1.5 / 8.0	55.9 / 22.0	140-200 / 63-90
161 W	1250	26.8	31.7 / 31.7	8.1 / -1.5 / 8.1	58.4 / 23.0	155-215 / 70-97

OVERVIEW

Tech Features

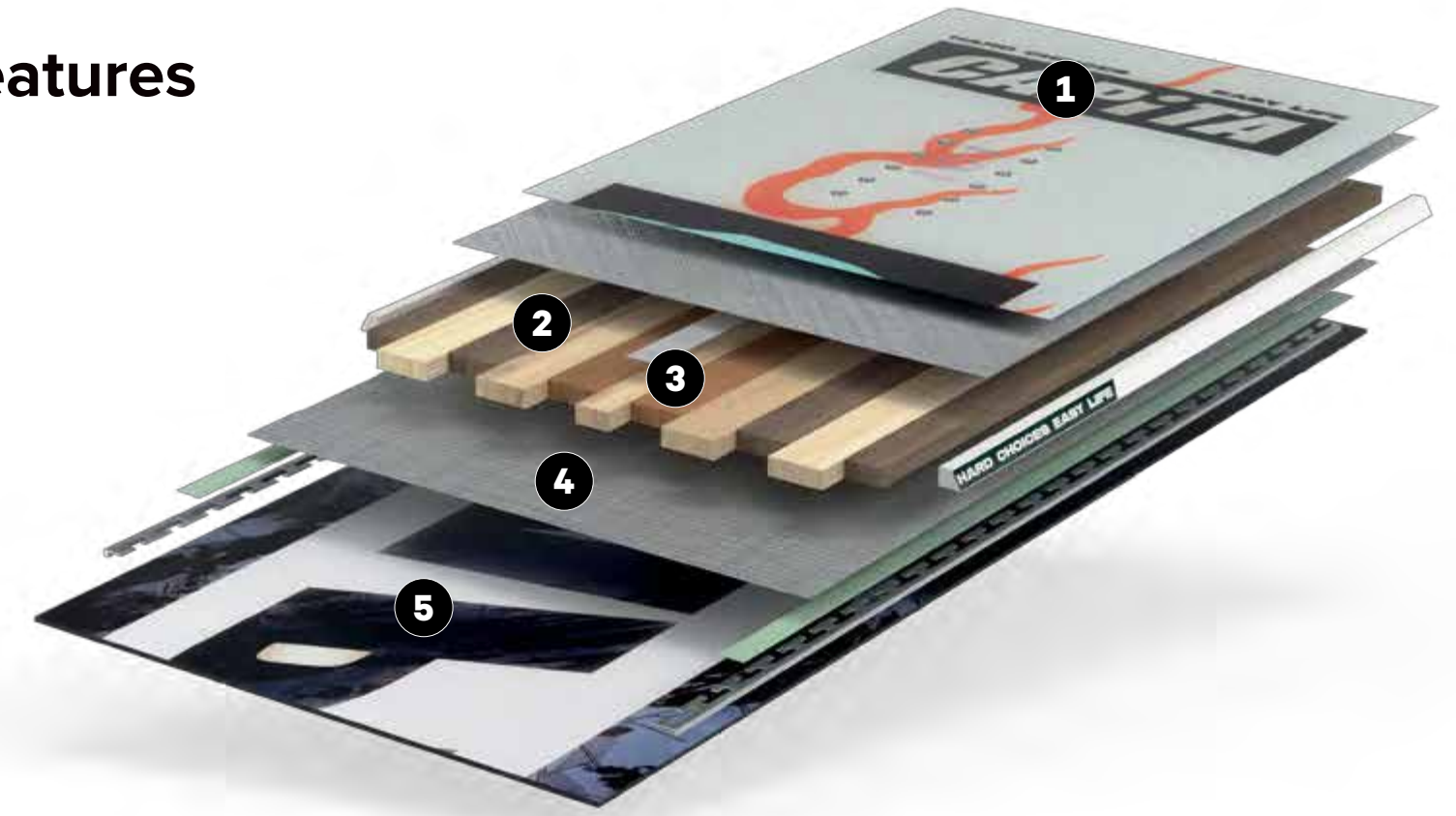

1 TOPSHEET TECH: **PLT Technology**
• Digital + Gloss/Matte Print
• Metallic Underlay

2 CORE: **META CORE™**

3 ADDITIVES: **TITANAL CENTERLINE BOOSTER**

4 GLASS + RESIN: **HOLYSHEET™ TRI/BI**
MAGIC BEAN™ RESIN

5 BASE: **QUANTUM DRIVE™**
• Sublimation

• **DEATH GRIP™ SIDECUT**

CORE:

- TITANAL
- BEECH
- PAULOWNIA
- POPLAR



The *Indoor Survival* excels at the resort and in the park with its Meta Core™ and Titanal Centerline Booster which creates incredible underfoot response in a light-weight package. Additionally, the *Indoors'* New Age Twin shape with Death Grip™ maximizes its carving capability.

RESHAPED!

ULTRAFEAR

Resort + Freestyle / True Twin / Traditional Camber

The *Ultrafear* has carved out a legendary position as one of the greatest jib and park boards in the world. For 2026 we've brought back its original shape for a retro take on this award-winning design.

Loaded with technical attributes that exceed its price tag, this series is ready to help you unlock new tricks and new features at your resort all winter long.



ULTRAFEAR

Resort + Freestyle / True Twin / Traditional Camber



ULTRAFEAR WIDE

Resort + Freestyle / True Twin / Traditional Camber



RESHAPED! ULTRAFEAR



The reshaped resort and park freestyle destroyer with new tech and a legendary reputation.

RIDER TYPE:
Resort / Freestyle

SHAPE:
True Twin

SIDECUT:
Radial

FLEX:
Twin 5.5

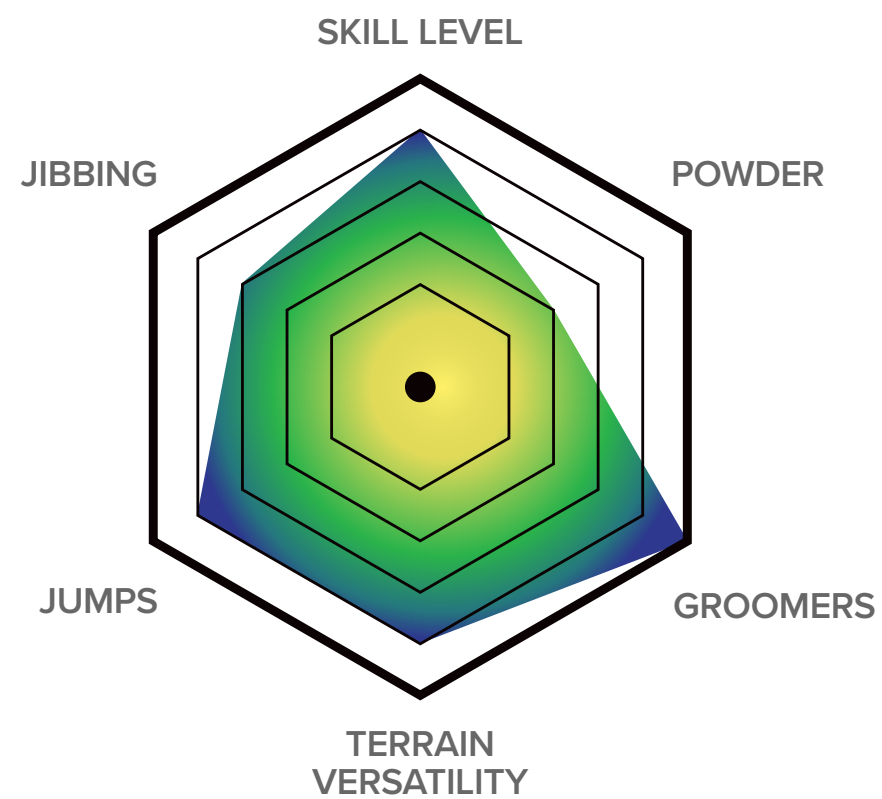

HYBRID CAMBER:
Resort V1 + Flat Kick Tech

Our *RESORT V1 Profile* boards take full advantage of the benefits of traditional camber, zero camber, and reverse camber. This next generation design allows you to get the pop and response of a cambered board with all the predictability and easy turn initiation of zero camber or reverse camber shapes.

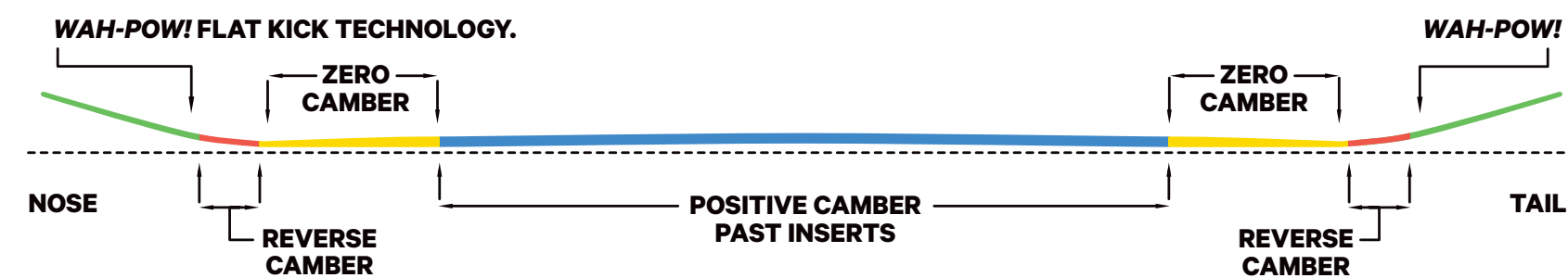

LENGTH	EFFECTIVE EDGE (mm)	WAIST	NOSE / TAIL	SIDECUT	REF. STANCE (cm / inches)	SUGGESTED WEIGHT (lbs / kg)
149	1150	25.0	29.3 / 29.3	7.6	50.8 / 20.0	100-150 / 45-68
151	1166	25.2	29.5 / 29.5	7.7	53.3 / 21.0	110-160 / 50-72
153	1182	25.3	29.7 / 29.7	7.8	53.3 / 21.0	120-170 / 54-81
155	1198	25.5	29.9 / 29.9	7.9	55.9 / 22.0	130-180 / 58-86
157	1213	25.6	30.0 / 30.0	8.0	55.9 / 22.0	140-190 / 63-90
153 W	1182	26.3	30.7 / 30.7	7.8	53.3 / 21.0	130-200 / 59-86
155 W	1198	26.5	30.9 / 30.9	7.9	55.9 / 22.0	140-190 / 63-90
157 W	1213	26.6	31.1 / 31.1	8.0	55.9 / 22.0	150-210 / 68-95

OVERVIEW

Tech Features



1 TOPSHEET TECH:
PLT Technology
• Digital Print
• Gloss/Matte Print
• Metallic Underlay

2 CORE:
P2 SUPERLIGHT CORE™

3 ADDITIVES:
1.5 mm FULL CORK
EDGE DAMPENING
SYSTEM

4 GLASS + RESIN:
NEW! HYBRID CARBON HOLYSHEET™
BI/BI
MAGIC BEAN™ RESIN

5 BASE:
SUPERDRIVE™ ADV
• Digital Print

CORE:
■ CARBON + ARAMID
■ CORK
■ PAULOWNIA
■ POPLAR



With a P2 Superlight Core™, 1.5mm Full Cork Edge Dampening System, and an all new Hybrid HolySheet™ directly interwoven with tip-to-tail Carbon Boosters, the reshaped *Ultrafear* is loaded with high-end technical attributes and delivers the ollie power and stability coveted by freestyle riders.

NEW SERIES!

DARK HORSE

Park + Resort / True Twin / Traditional Camber

The *Dark Horse* is a new wallet-friendly iteration of the team-favorite *Outsiders* that crushes park jumps, side hits, and freestyle features.

Pared down with only technical components you need in an array of standard and wide sizes – *Dark Horse* leverages its dynamic design to deliver maximum power and performance.



DARK HORSE

Park + Resort / True Twin / Traditional Camber



DARK HORSE WIDE

Park + Resort / True Twin / Traditional Camber



NEW SERIES!

DARK HORSE

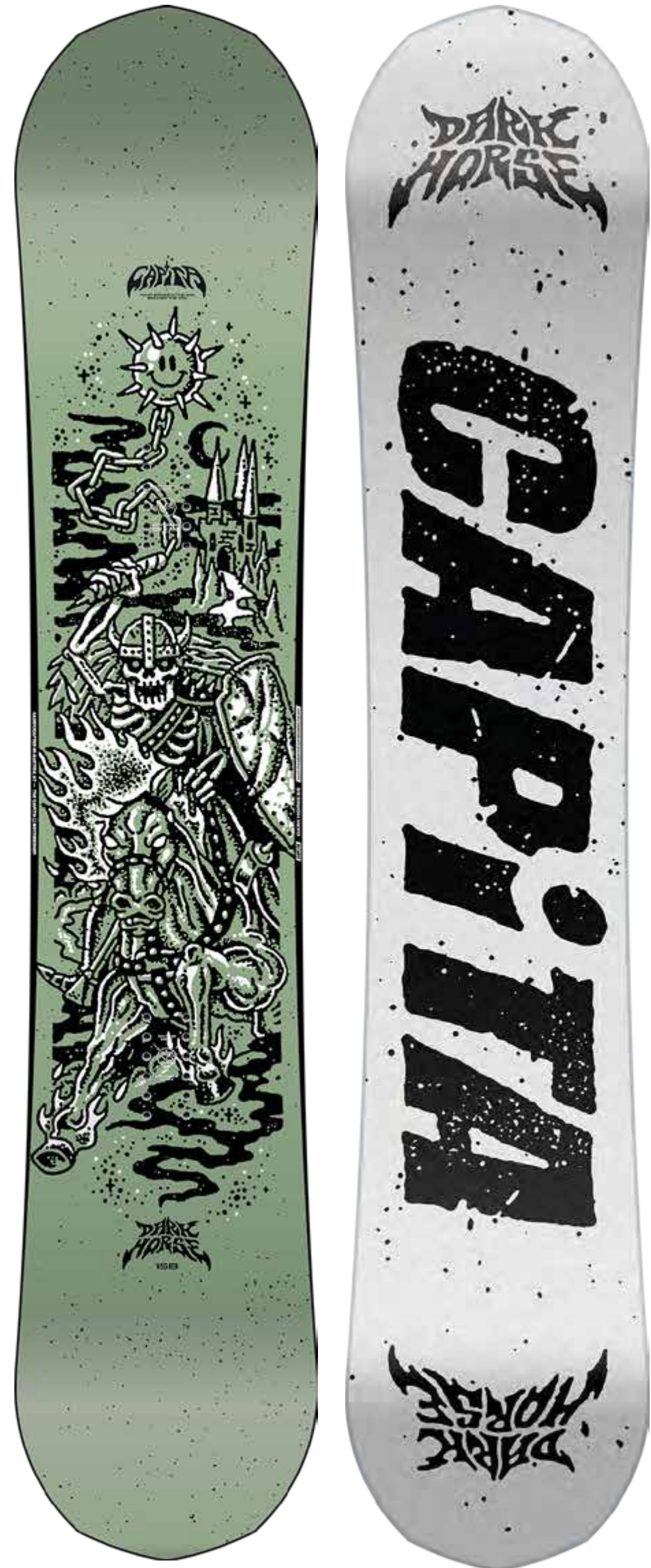

A budget friendly build for the progressive park and resort rider that loves transitions.

RIDER TYPE:
Park / Resort

SHAPE:
True Twin

SIDECUT:
Radial

FLEX:
Twin 6

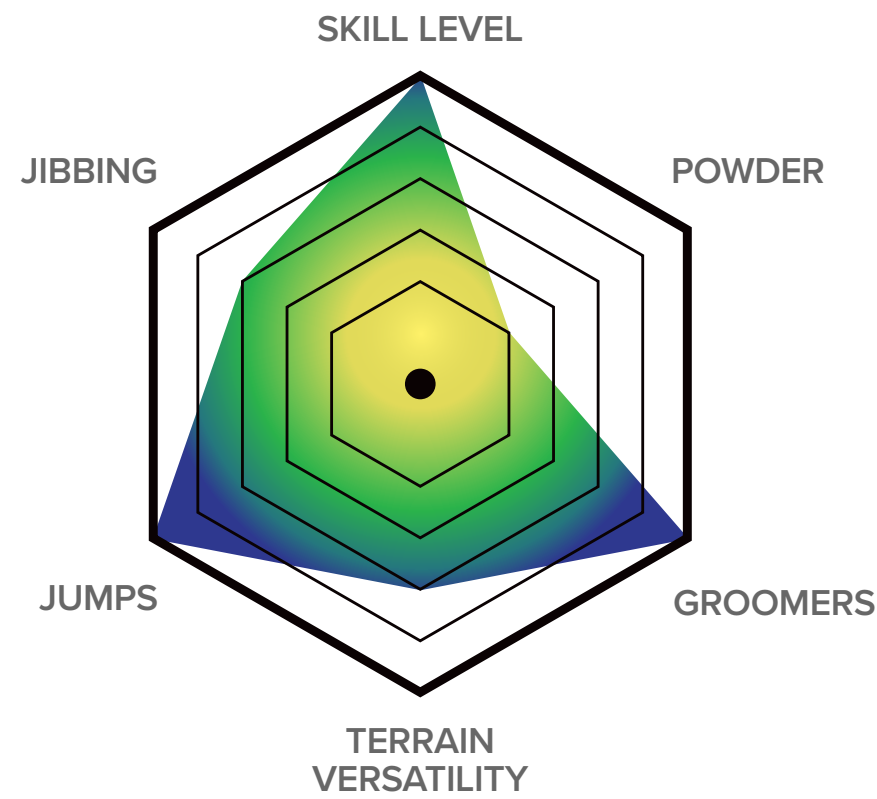

TRADITIONAL CAMBER:
Park V1

The *PARK V1* camber configuration zeros out a traditional camber approach 4 cm before the end of the sidecut. The small zero camber sections provide a more controlled ride while retaining the response and power of a cambered board.



LENGTH	EFFECTIVE EDGE (mm)	WAIST	NOSE / TAIL	SIDECUT	REF. STANCE (cm / inches)	SUGGESTED WEIGHT (lbs / kg)
148	1150	24.8	29.0 / 29.0	7.7	50.8 / 20.0	90-140 / 40-63
150	1170	25.0	29.3 / 29.3	7.8	53.3 / 21.0	100-150 / 45-68
152	1185	25.2	29.5 / 29.5	7.9	53.3 / 21.0	110-160 / 49-72
154	1188	25.3	29.7 / 29.7	8.0	53.3 / 21.0	120-180 / 54-81
156	1220	25.5	29.9 / 29.9	8.1	55.9 / 22.0	130-190 / 59-86
158	1245	25.8	30.2 / 30.2	8.3	55.9 / 22.0	140-200 / 63-90
154 W	1200	25.8	30.1 / 30.1	8.0	53.3 / 21.0	120-180 / 54-81
156 W	1220	26.0	30.4 / 30.4	8.1	55.9 / 22.0	130-190 / 59-86
158 W	1230	26.4	30.8 / 30.8	8.3	55.9 / 22.0	140-200 / 63-90
160 W	1250	26.8	31.2 / 31.2	8.5	58.4 / 23.0	150-210 / 68-95

OVERVIEW

Tech Features

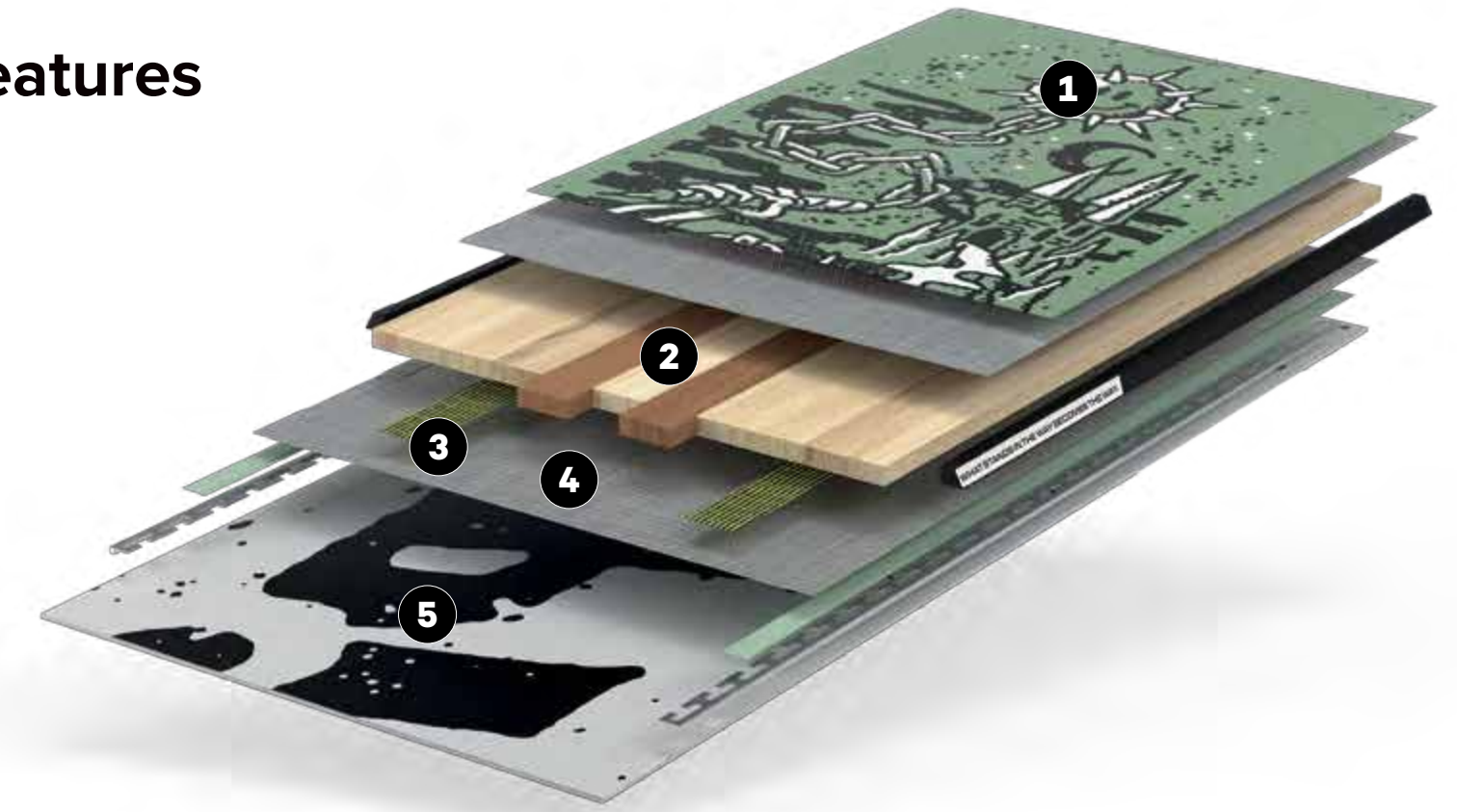

1 TOPSHEET TECH:
• Pearlescent Screen
+ Gloss/Matte Print

2 CORE:
DUAL CORE™

3 ADDITIVE:
2 x 30 mm
CARBON ARAMID
BOOSTERS

4 GLASS + RESIN:
SPECIAL BLEND FIBERGLASS
MAGIC BEAN™ RESIN

5 BASE:
SUPERDRIVE™
• Screen Print

CORE:
■ CARBON ARAMID
■ BEECH
■ POPLAR

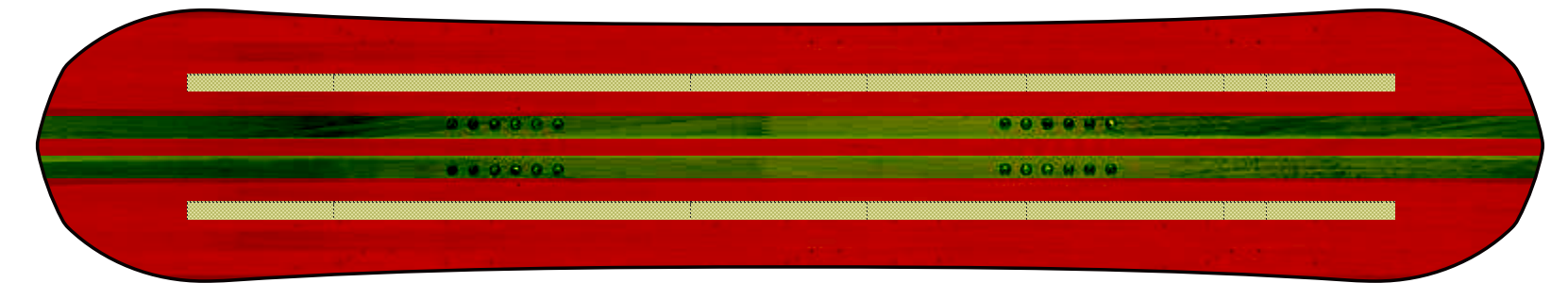

The *Dark Horse* maximizes the power potential of a lightweight and energetic board in a budget friendly construction. It delivers the pop and power, demanded by progressive freestyle riders through with its tried and trusted combination of Dual Core™ and Special Blend Fiberglass further enhanced with 2 x 30 mm Carbon Aramid Boosters.

PATHFINDER

Freestyle / True Twin / Reverse Camber

The *Pathfinder* is the perfect board for a wide range of riders looking to progress their riding at a minimal cost. It is fun, maneuverable, easy to ride and capable of big things.

The *Pathfinder* provides a user-friendly and confident chassis for riders new to the game, with plenty of upside for intermediate or advanced park riders looking for a value-packed opportunity for the next freestyle-focused resort board.



PATHFINDER

Freestyle / True Twin / Reverse Camber

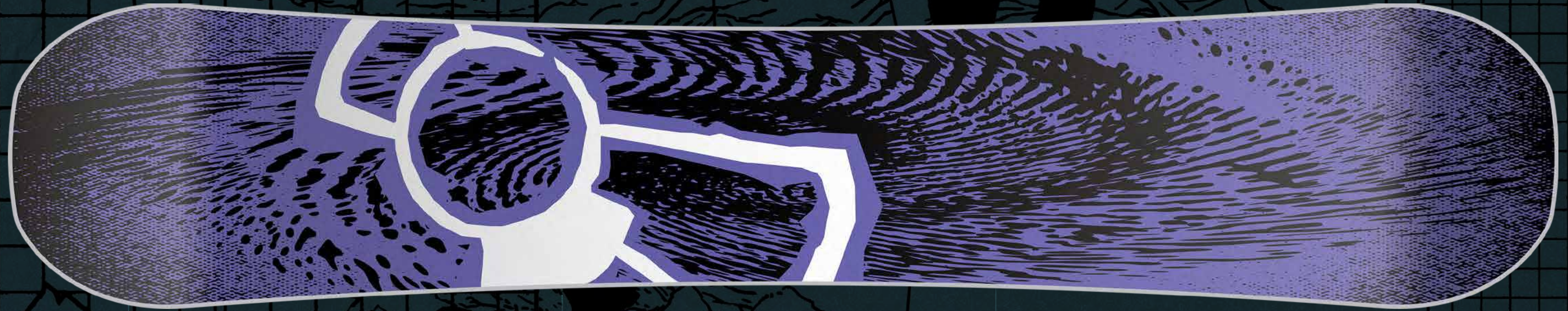
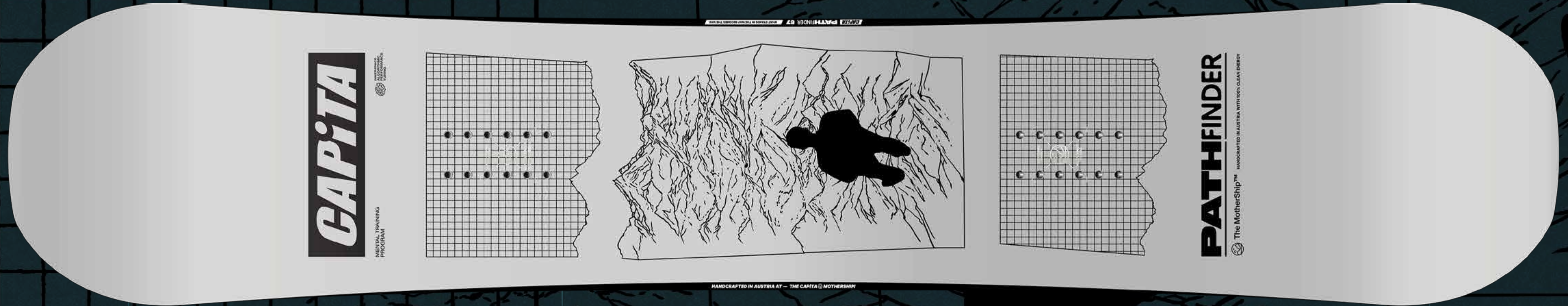

PATHFINDER WIDE

Freestyle / True Twin / Reverse Camber

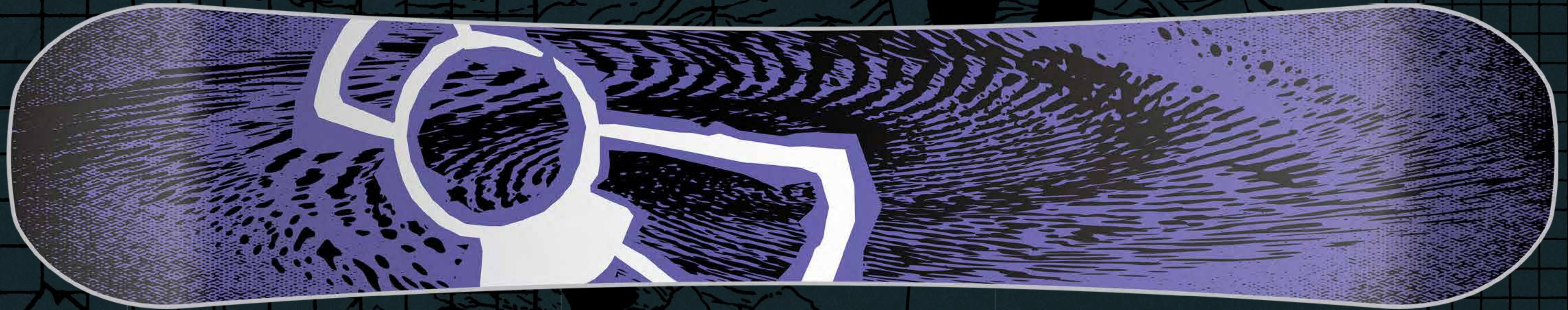
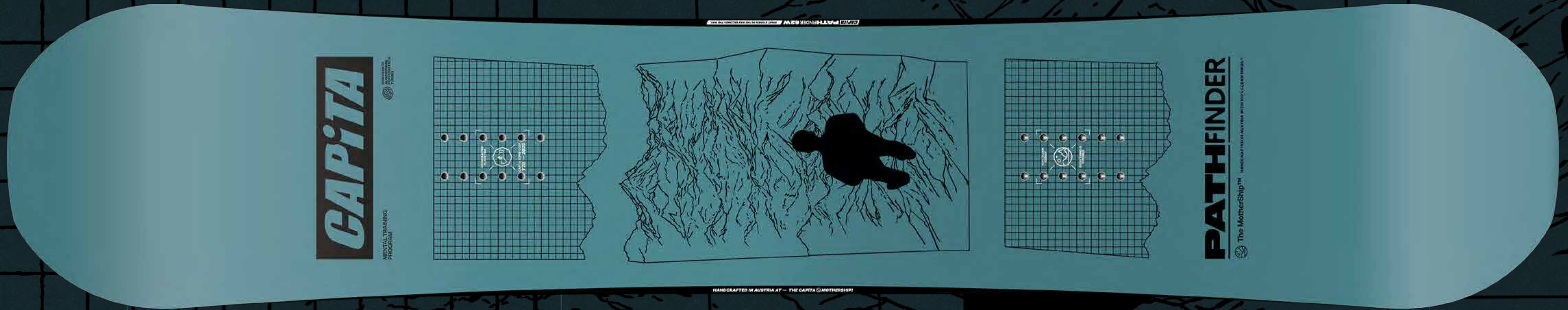

PATHFINDER

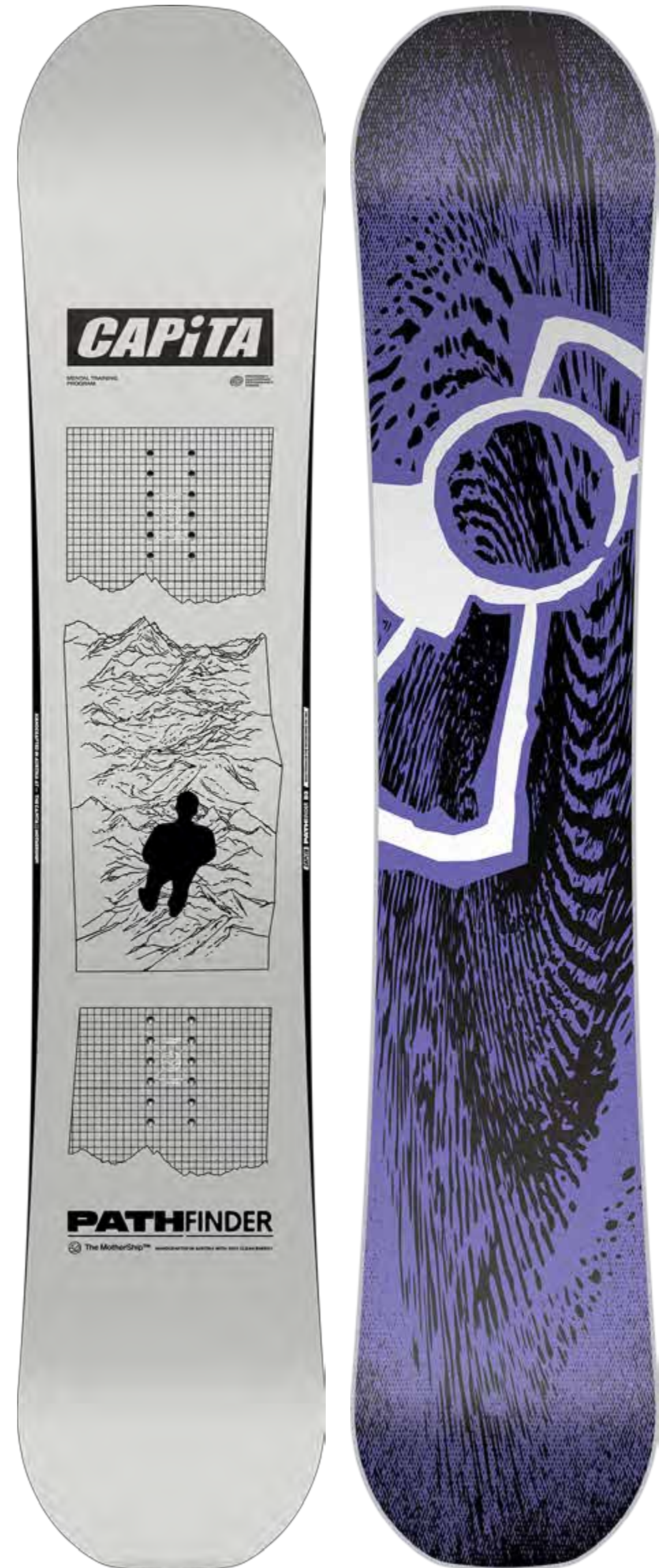

From the new rider to the next freestyle master, this series offers big potential at an affordable price.

RIDER TYPE:
Freestyle

SHAPE:
True Twin

SIDECUT:
Radial

FLEX:
Twin 4

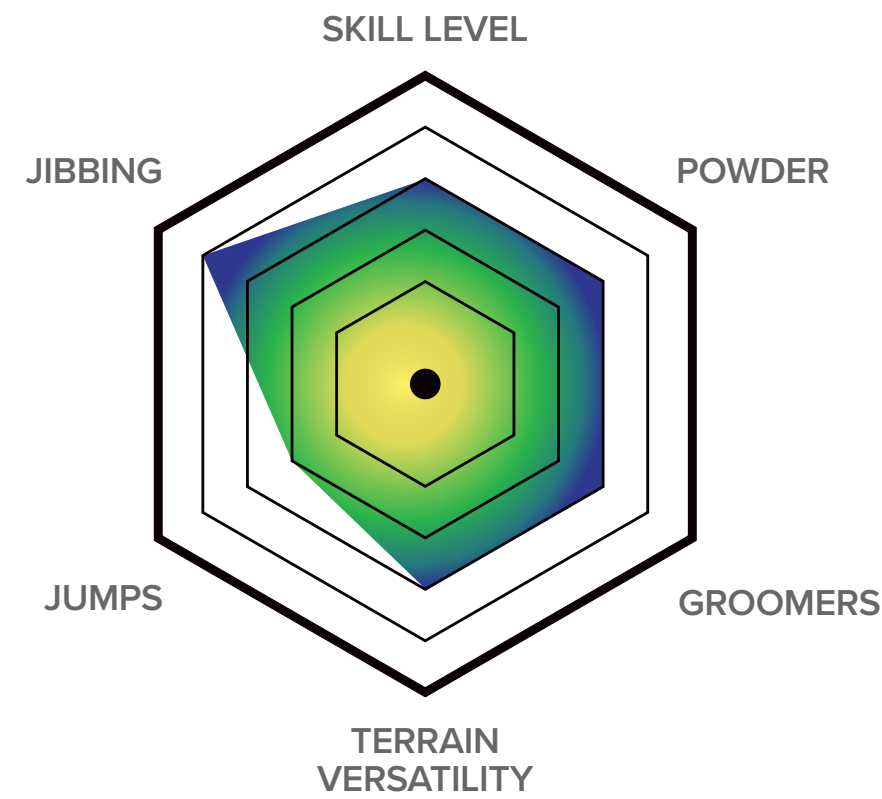

REVERSE CAMBER:
Park V2 + Flat Kick Tech

These versatile boards feature a dual reverse camber Flat Kick freestyle shape. A zero camber section throughout the insert area provides a stable skate-style feel, while elevated contact points turn on a dime and float effortlessly in powder.

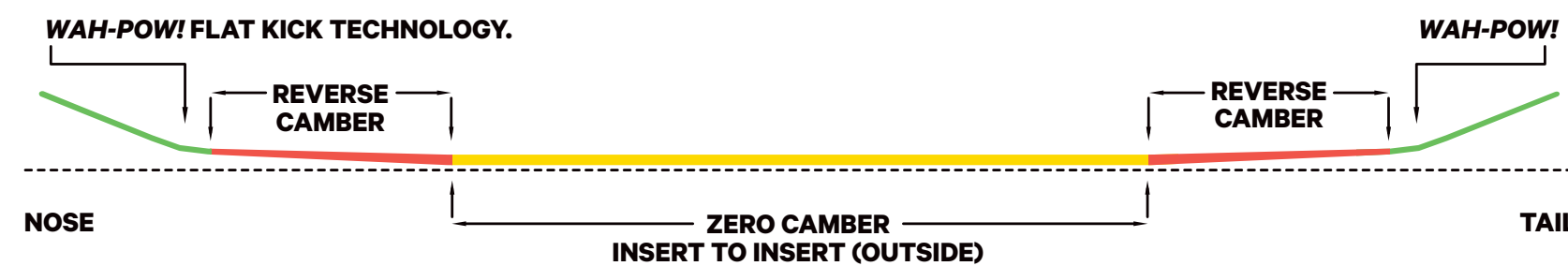

LENGTH	EFFECTIVE EDGE (mm)	WAIST	NOSE / TAIL	SIDECUT	REF. STANCE (cm / inches)	SUGGESTED WEIGHT (lbs / kg)
145	1154	24.6	29.0 / 29.0	7.4	50.8 / 20.0	80-120 / 36-54
147	1171	24.8	29.2 / 29.2	7.5	50.8 / 20.0	90-140 / 41-63
149	1186	25.0	29.5 / 29.5	7.6	50.8 / 20.0	95-150 / 43-68
151	1202	25.2	29.7 / 29.7	7.7	53.3 / 21.0	100-155 / 45-70
153	1218	25.4	30.0 / 30.0	7.8	53.3 / 21.0	110-170 / 49-77
155	1234	25.6	30.3 / 30.3	7.9	55.9 / 22.0	120-180 / 54-81
157	1250	25.8	30.5 / 30.5	8.0	55.9 / 22.0	140-200 / 63-90
153 W	1218	26.0	30.6 / 30.6	7.8	53.3 / 21.0	110-170 / 50-77
155 W	1234	26.1	30.8 / 30.8	7.9	55.9 / 22.0	130-190 / 59-86
157 W	1250	26.3	31.0 / 31.0	8.0	55.9 / 22.0	140-200 / 64-91
159 W	1265	26.5	31.2 / 31.2	8.2	55.9 / 22.0	150-210 / 68-95
162 W	1291	26.8	31.6 / 31.6	8.2	58.4 / 23.0	160-220 / 72-99

OVERVIEW

Tech Features

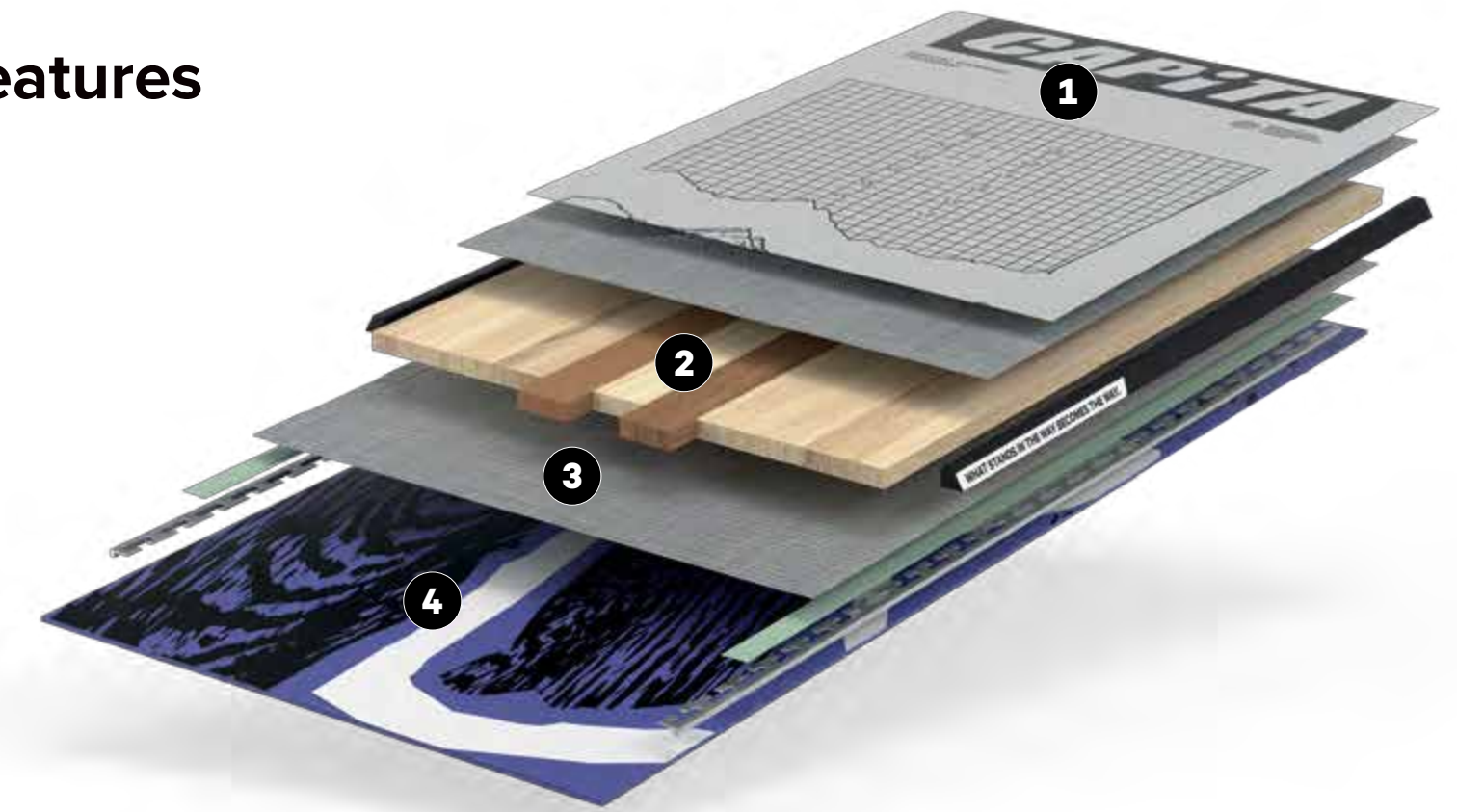

1 TOPSHEET TECH:
• Metallic Screen
+ Gloss/Matte Print

2 CORE:
DUAL CORE™

3 GLASS + RESIN:
SPECIAL BLEND FIBERGLASS
MAGIC BEAN™ RESIN

4 BASE:
SUPERDRIVE™
• Screen Print

• BITTER END™ DEFLECTION TUNING

CORE:
■ BEECH
■ POPLAR



The *Pathfinder* excels in a variety of resort and freestyle terrain with the tried and trusted combination of Dual Core™ and Special Blend Fiberglass + Magic Bean™ Resin.

SPACE METAL FANTASY

Women's / Resort + Freestyle / True Twin /
Reverse Camber

The award winning *Space Metal Fantasy* is widely regarded as one of the best women's park boards on the market. However, to be fair, labeling it as a park board severely understates its potential.

We present it as a park series for classification purposes, but in truth, it's much more than that. The *Space Metal Fantasy* is fun for carving around the slopes, playing on features in the park, and even floats ridiculously well in powder.

This very forgiving reverse camber shape provides a fun experience for beginner to intermediate riders looking to expedite the learning curve and take their riding to the next level on many different types of terrain.



SPACE METAL FANTASY

Women's / Resort + Freestyle / True Twin / Reverse Camber

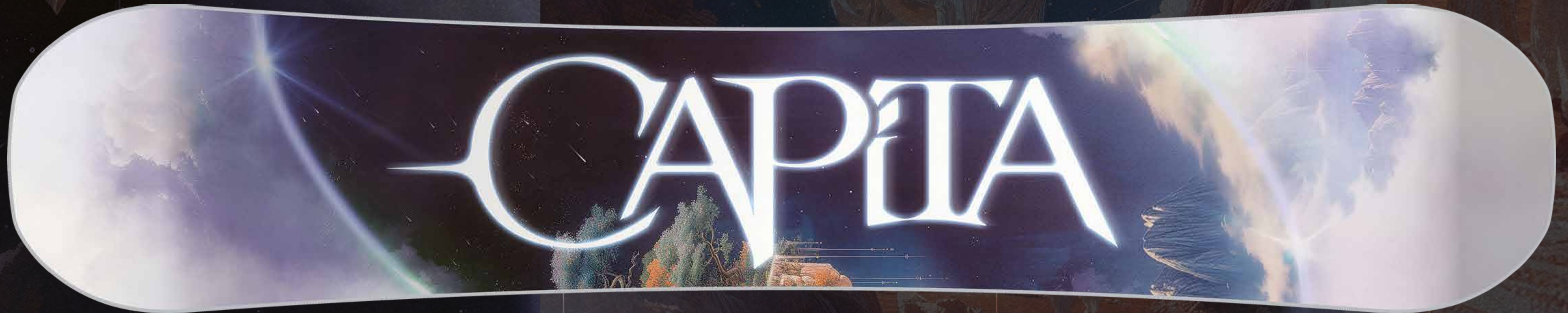

SPACE METAL FANTASY WIDE

Women's / Resort + Freestyle / True Twin / Reverse Camber

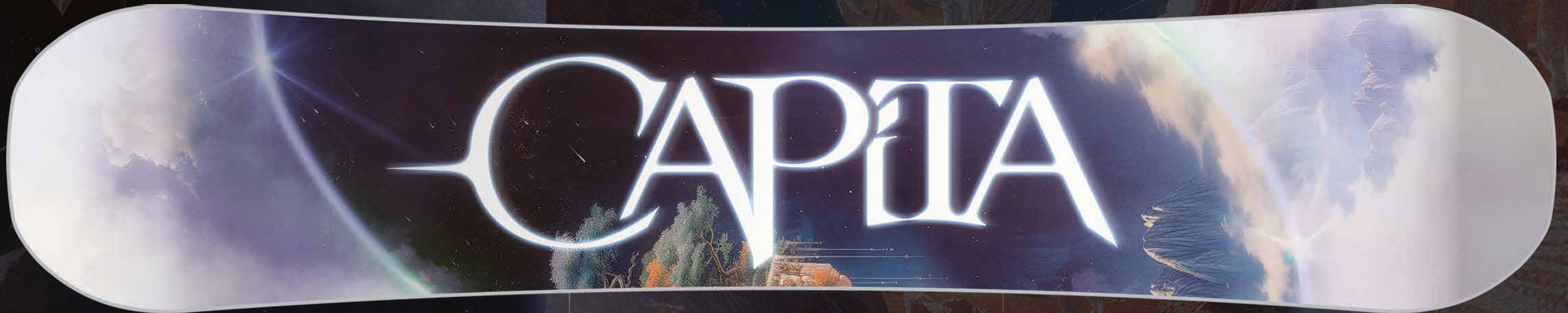

SPACE METAL FANTASY

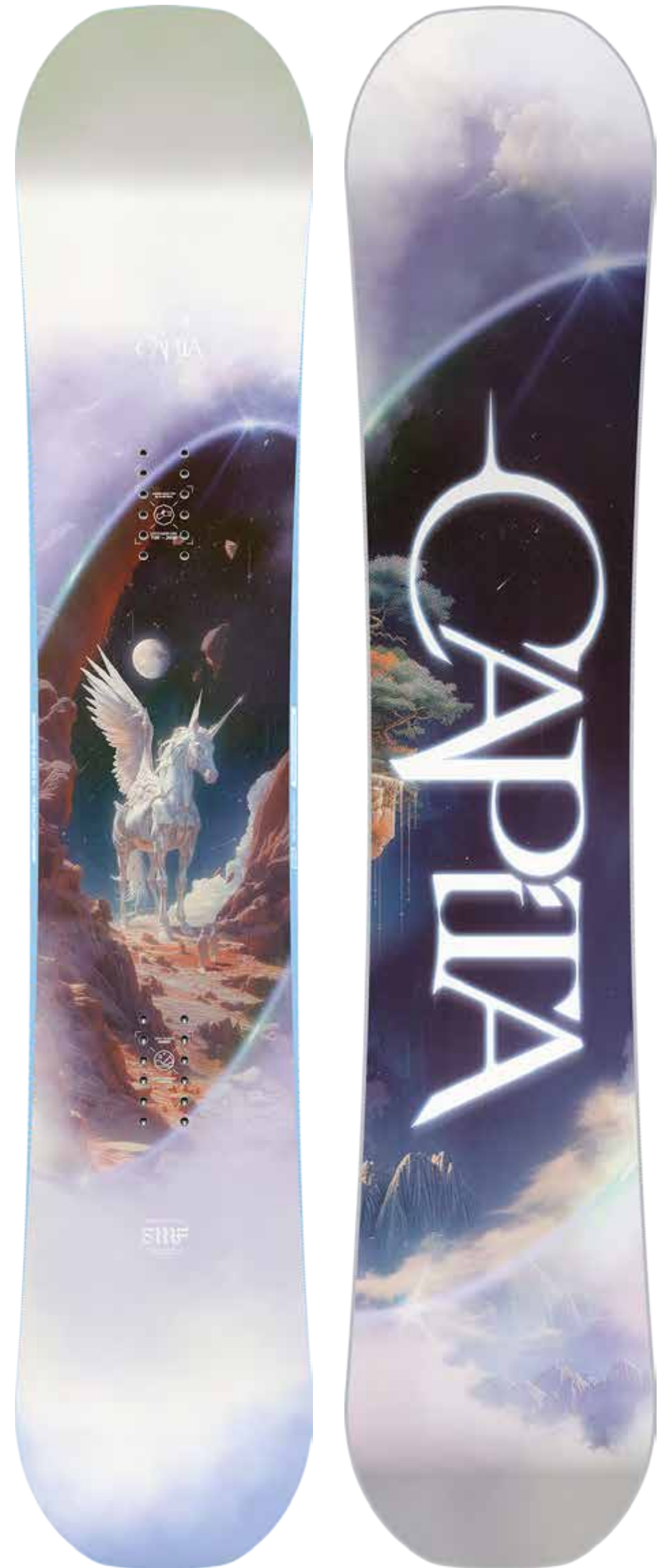

The easy-riding board that can do anything for the rider that does a little of everything.

RIDER TYPE:
Freestyle / Resort

SHAPE:
True Twin

SIDECUT:
Radial

FLEX:
Twin 4

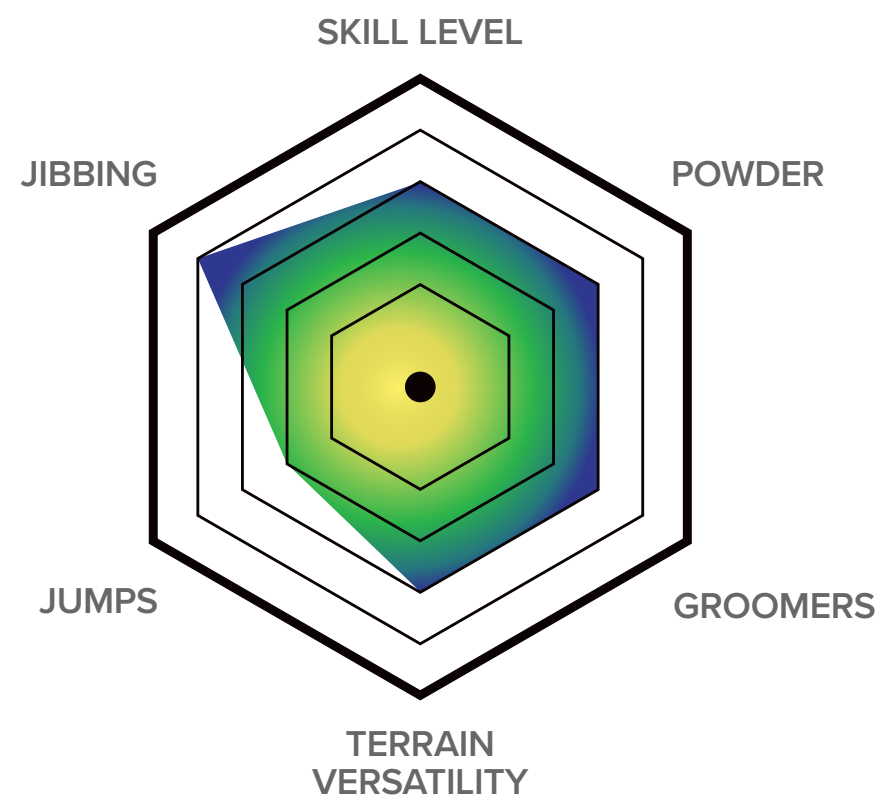

REVERSE CAMBER:
Park V2 + Flat Kick Tech

These versatile boards feature a dual reverse camber Flat Kick freestyle shape. A zero camber section throughout the insert area provides a stable skate-style feel, while elevated contact points turn on a dime and float effortlessly in powder.

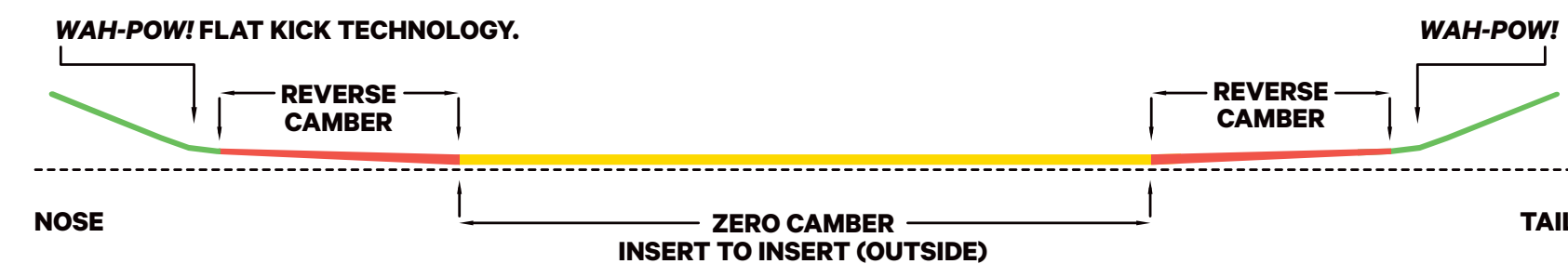

LENGTH	EFFECTIVE EDGE (mm)	WAIST	NOSE / TAIL	SIDECUT	REF. STANCE (cm / inches)	SUGGESTED WEIGHT (lbs / kg)
139	1106	22.8	27.2 / 27.2	6.7	45.7 / 18.0	80-130 / 36-59
141	1121	23.1	27.6 / 27.6	6.8	48.3 / 19.0	85-135 / 38-61
143	1137	23.3	27.8 / 27.8	6.9	48.3 / 19.0	90-140 / 41-63
145	1153	23.6	28.1 / 28.1	7.1	50.8 / 20.0	95-145 / 43-66
147	1171	23.9	28.4 / 28.4	7.3	50.8 / 20.0	100-150 / 45-68
149	1186	24.1	28.6 / 28.6	7.5	50.8 / 20.0	105-155 / 47-70
151	1203	24.3	28.8 / 28.8	7.7	53.3 / 21.0	110-160 / 49-73
153	1219	24.5	29.0 / 29.0	7.9	53.3 / 21.0	120-170 / 54-77
145 W	1154	24.6	28.9 / 28.9	7.1	50.8 / 20.0	95-145 / 43-66
149 W	1186	25.0	29.4 / 29.4	7.5	50.8 / 20.0	105-155 / 47-70
153 W	1218	25.4	30.0 / 30.0	7.9	53.3 / 21.0	120-170 / 54-77

OVERVIEW

Tech Features

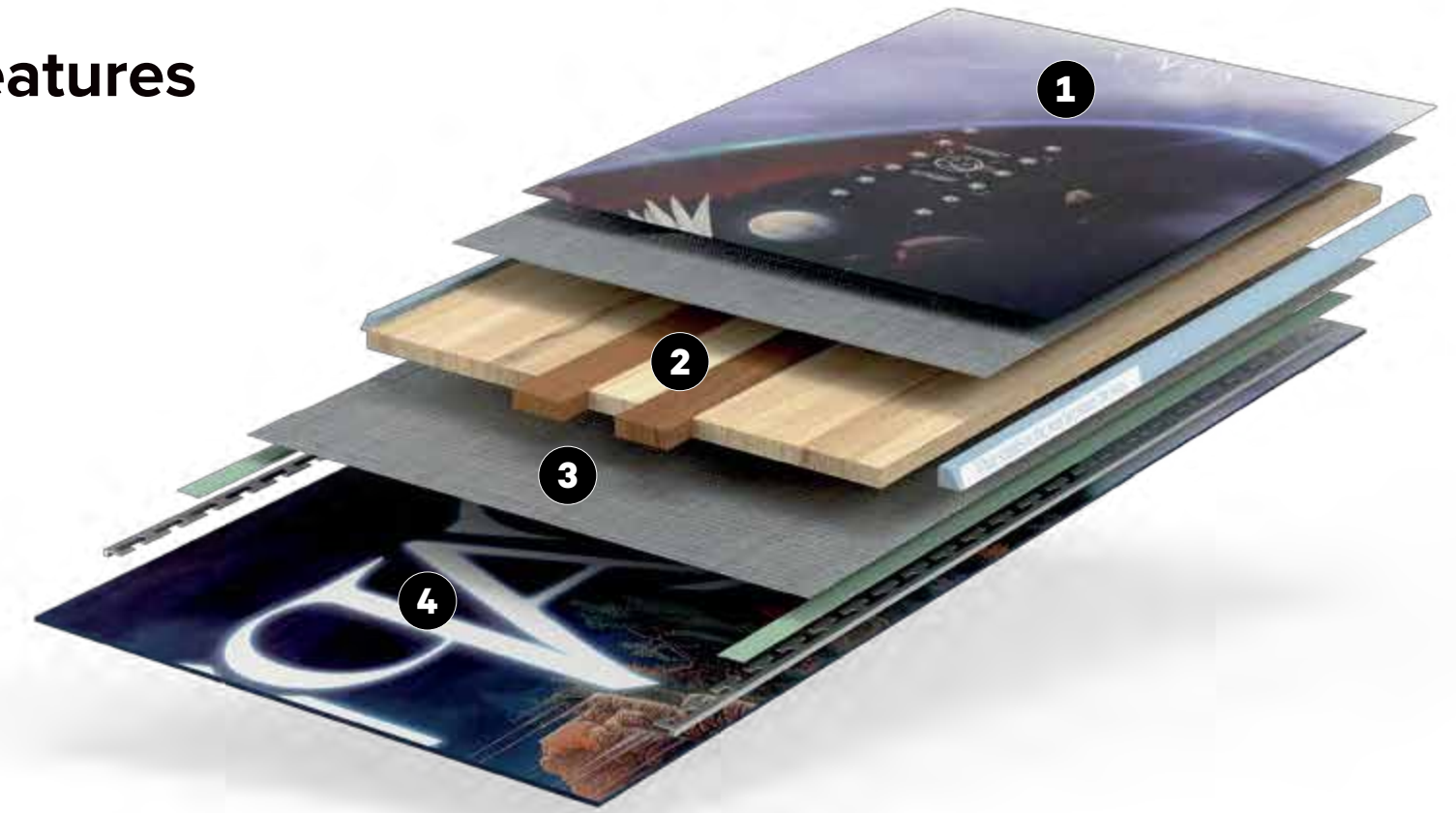

1
TOPSHEET TECH:
PLT Technology
• Digital Print
• Metallic Underlay

2
CORE:
DUAL CORE™

3
GLASS + RESIN:
SPECIAL BLEND FIBERGLASS
MAGIC BEAN™ RESIN

4
BASE:
SUPERDRIVE™
• Digital Print

• BITTER END™ DEFLECTION TUNING

CORE:
■ BEECH
■ POPLAR

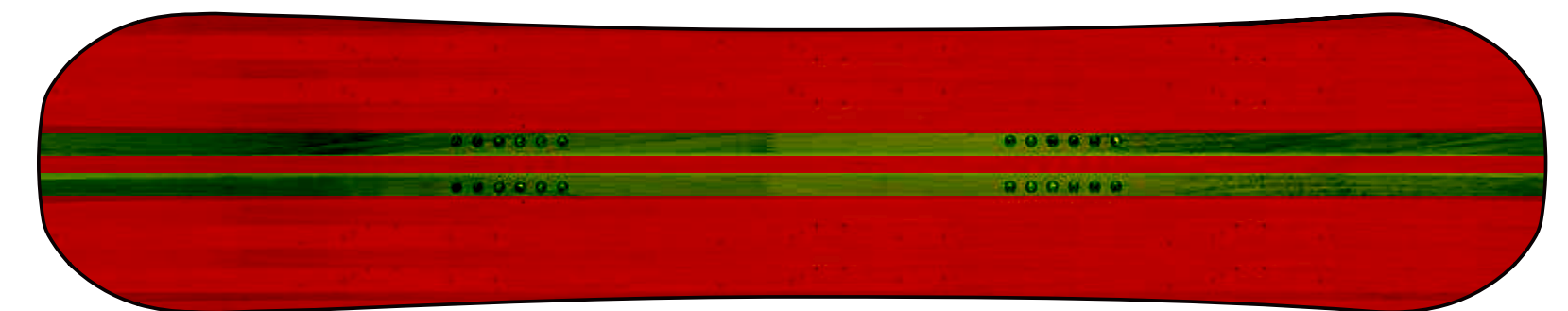

The *Space Metal Fantasy* excels in a variety of resort and freestyle terrain with the tried and trusted combination of Dual Core™ and Special Blend Fiberglass + Magic Bean™ Resin.

FREERIDE

BR

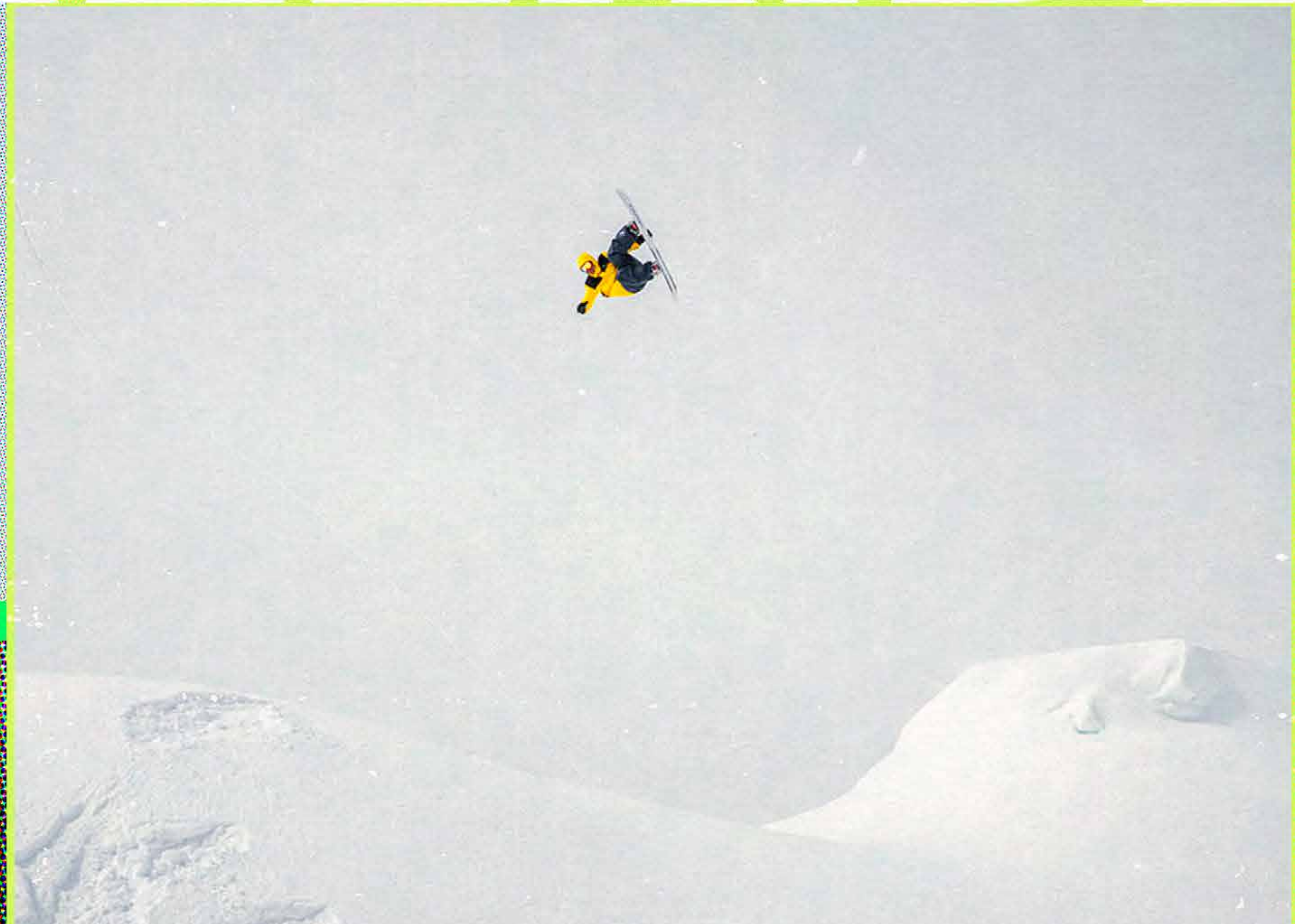
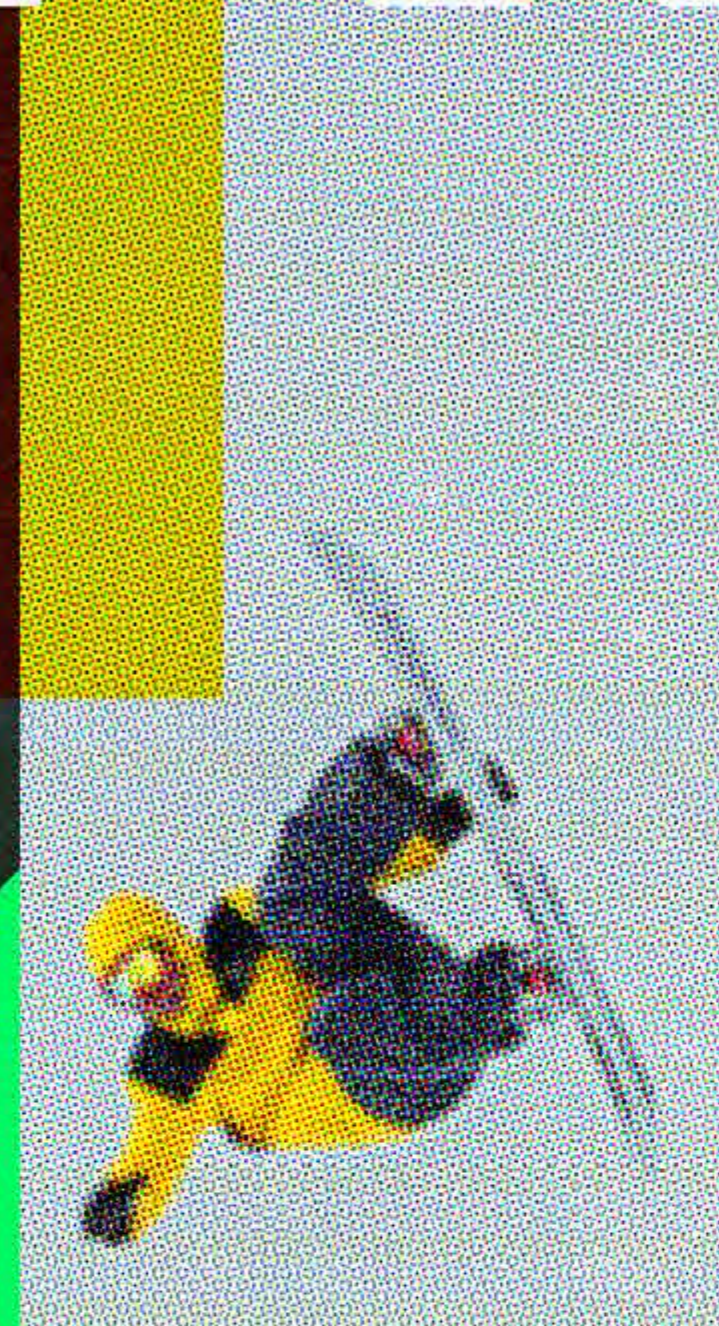

BRANDON COCARD

JESS KIMURA
KAZU KOKUBO
ARTHUR LONGO
TORSTEIN HORGMO
MILES FALLON

Engineered to float in powder and thrive in the mountains.

FREERIDE



MEGA DEATH



MEGA MERC



MEGA SPLIT



THE BLACK SNOWBOARD
OF DEATH



KAZU KOKUBO PRO



MERCURY

FREERIDE



THE NAVIGATOR



THE NAVIGATOR
WMN



NAVIGATOR SPLIT



NAVIGATOR WMN
SPLIT



THE EQUALIZER

THE BLACK SNOWBOARD OF DEATH

All-Mtn + Freeride / Directional / Hybrid Camber

The Black Snowboard of Death has achieved legendary status as an all-terrain slayer, boasting an impressive collection of accolades. Over the last 25 years, it has undergone constant evolution and modification in the relentless pursuit of perfection. The one constant amidst these changes has been its iconic name.

Featuring a finely balanced directional shape and high-powered construction, this custom-designed rocketship offers exceptional control, enabling riders to elevate their skills and navigate varying terrain and changing conditions with confidence.



Y2K — 2025

*Our life began
when the world was supposed to end.*

THE BLACK SNOWBOARD OF DEATH

All-Mtn + Freeride / Directional / Hybrid Camber



THE BLACK SNOWBOARD OF DEATH

KEVIN JONES 159

All-Mtn + Freeride / Directional / Hybrid Camber



THE BLACK SNOWBOARD OF DEATH



The OG legendary CAPiTA freeride series for the advanced all-mountain technician.

RIDER TYPE:
All-Mtn / Freeride

SHAPE:
**Directional
0.8" Setback**

SIDECUT:
**New Age
Progressive
Death Grip™**

FLEX:
**Directional
6.5**

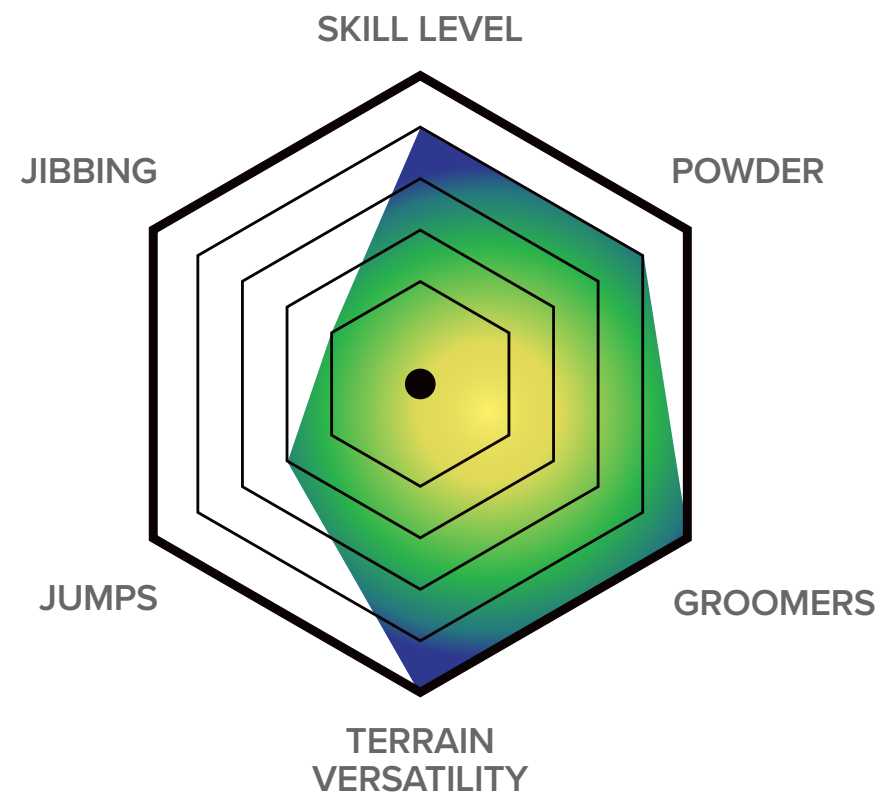

HYBRID CAMBER:
Alpine V1 Directional + Flat Kick Tech

The *ALPINE V1 Profile* design features mid-body camber with a flat tail and a reverse cambered nose. This allows for tons of pop and stability on hard pack while increasing float and landing power, improving the rider's performance in deep snow. The camber runs longer in the tail—providing extra power for the ascent or for larger riders drawn to a dedicated wide series.

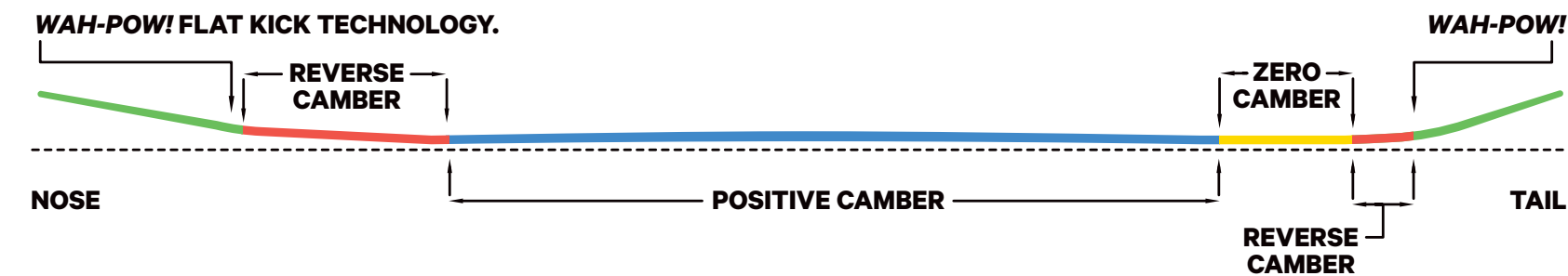

LENGTH	EFFECTIVE EDGE (mm)	WAIST	NOSE / TAIL	TAPER	SIDECUT	REF. STANCE (cm / inches)	SUGGESTED WEIGHT (lbs / kg)
156	1197	25.6	29.6 / 29.5	1.1	8.2 / 7.8 / 7.6	55.9 / 22.0	130-190 / 59-86
159	1221	25.9	30.0 / 29.9	1.1	8.4 / 8.0 / 7.8	55.9 / 22.0	140-200 / 63-90
162	1245	26.2	30.4 / 30.3	1.1	8.6 / 8.2 / 8.0	58.4 / 23.0	150-210 / 68-95
157 W	1205	26.4	30.5 / 30.4	1.1	8.2 / 7.8 / 7.7	55.9 / 22.0	140-200 / 63-90
161 W	1237	26.7	30.9 / 30.8	1.1	8.5 / 8.1 / 8.0	58.4 / 23.0	150-210 / 68-95
165 W	1269	27.0	31.2 / 31.1	1.0	8.8 / 8.4 / 8.2	58.4 / 23.0	160-220 / 72-100
169 W	1301	27.4	31.7 / 31.6	1.1	9.0 / 8.6 / 8.5	58.4 / 23.0	170-230 / 77-104

OVERVIEW

Tech Features

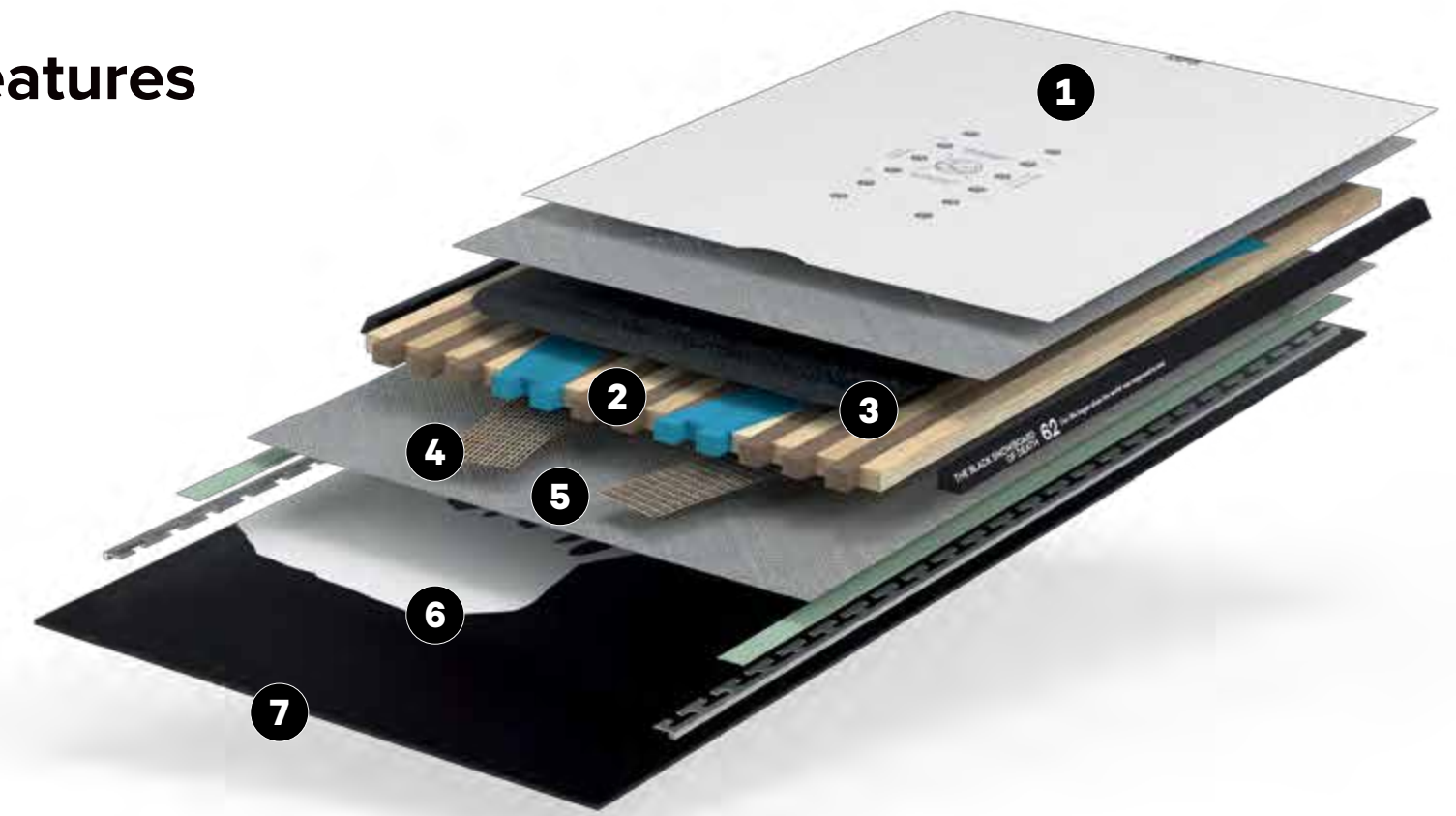

- 1** TOPSHEET TECH: PLT Technology • Screen + Gloss/Matte Print
- 2** CORE: THERMOPOLYMER HOVER CORE™
- 3** ADDITIVES: CARBON FLEECE POWER SHIELD™
- 4** ADDITIVES: 4 x 25 mm CARBONFLAX™ AMPLIFIER
- 5** GLASS + RESIN: HOLYSHEET™ TRI/TRI MAGIC BEAN™ RESIN
- 6** BASE: HYPERDRIVE™ ADV XT • Die-cut
MOONSHOT OMNI-TUNE™
- 7** BASE TECH: INLAID ALLOY SKID PLATES
• DEATH GRIP™ SIDECUT

CORE:

- PET
- CARBONFLAX™
- CARBON FLEECE
- PAULOWNIA
- POPLAR

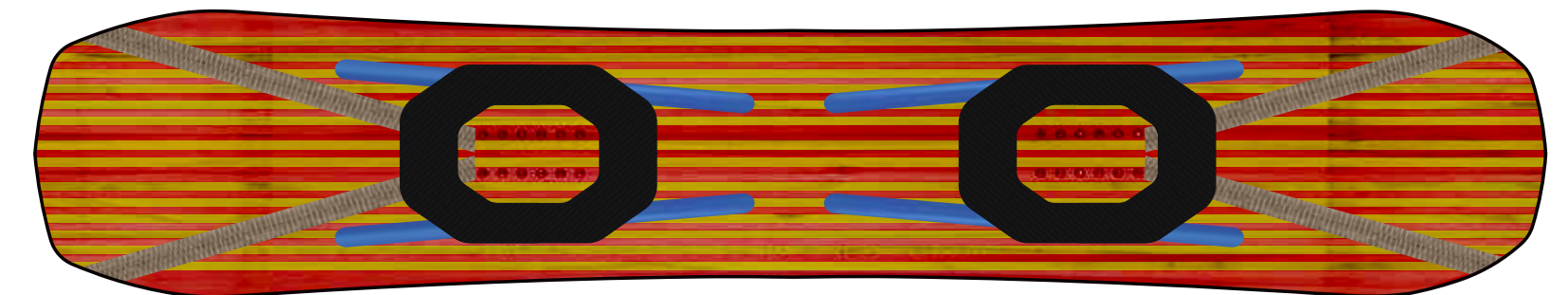

This iconic CAPiTA series is packed with technology—integrating a Thermopolymer Hover Core™ with Carbon Fleece Power Shields™ and Carbonflax™ Amplifiers for a high-powered construction which allows for incredible control.

KAZU KOKUBO PRO

All-Mtn + Freeride / Directional / Hybrid Camber

Fast and powerful, this is the switchblade of powder boards.

The *Kazu Kokubo Pro* comes in a compact chassis with a powder nose and a slightly tapered tail, making this award-winning series quick and maneuverable.

This versatility is perfect for side-country powder mornings that transition to resort riding after you've tracked your secret stash. And, while it's a lofty goal, this board is your first step towards trying to emulate Kazu's legendary riding style.



KAZU KOKUBO PRO

All-Mtn + Freeride / Directional / Hybrid Camber



KAZU KOKUBO PRO WIDE

All-Mtn + Freeride / Directional / Hybrid Camber



KAZU KOKUBO PRO



Inspired by *Kazu's* legendary riding style, this series is dedicated to big mountain freestylers.

RIDER TYPE:
All-Mtn / Freeride

SHAPE:
**Directional Twin
0.8" Set Back**

SIDECUT:
Radical Taper

FLEX:
**Directional
6.5**

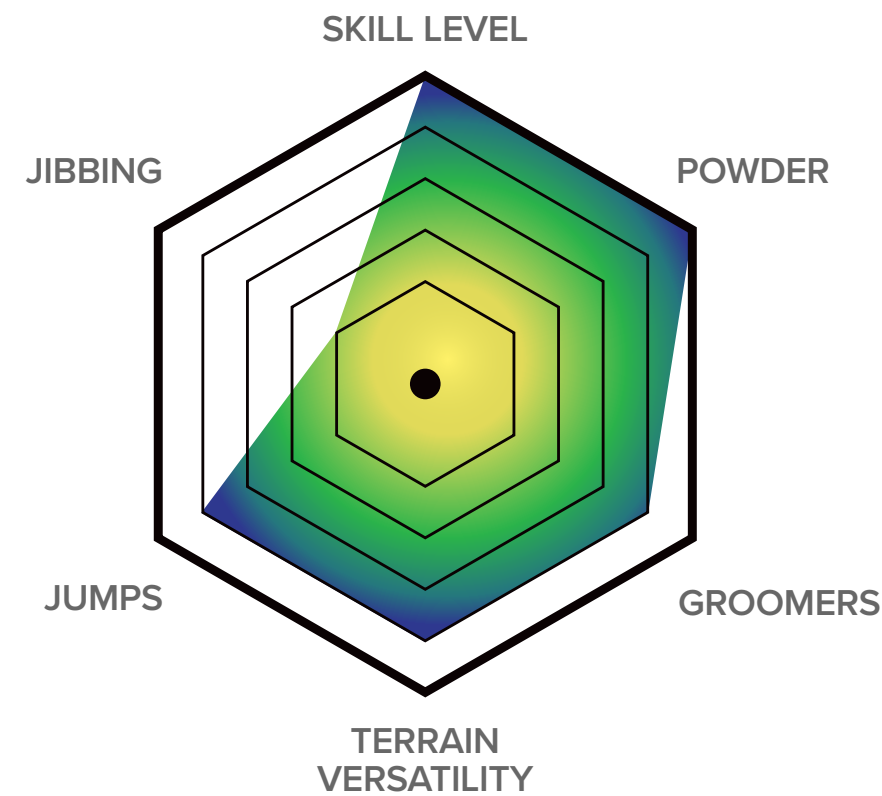

HYBRID CAMBER:
Resort V3 Directional

The *RESORT V3 Profile* provides the best of both worlds. It has a raised camber platform through the inserts to retain high-speed edge hold through variable terrain, elevated contact points to land and float in powder, and traditional tip and tail arcs for smoother transitions.

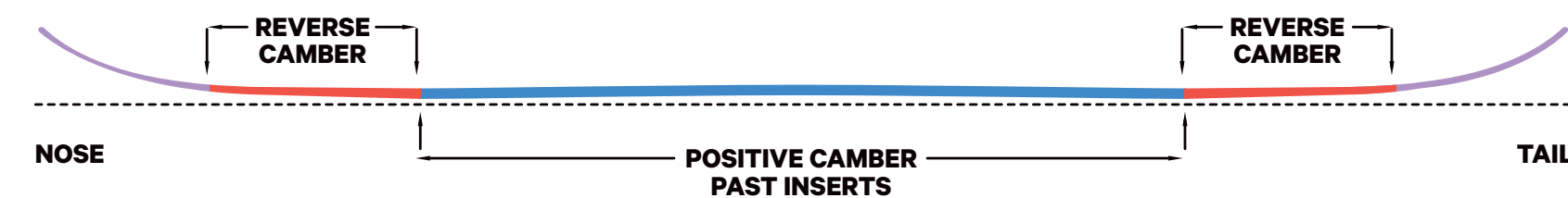

LENGTH	EFFECTIVE EDGE (mm)	WAIST	NOSE / TAIL	TAPER	SIDECUT	REF. STANCE (cm / inches)	SUGGESTED WEIGHT (lbs / kg)
151	1170	25.1	29.6 / 28.9	6.3	8.0	53.3 / 21.0	100-150 / 45-68
154	1200	25.3	30.0 / 29.2	7.7	8.2	53.3 / 21.0	100-160 / 45-72
157	1222	25.5	30.4 / 29.5	9.9	8.4	55.9 / 22.0	130-190 / 59-86
160	1254	25.7	30.7 / 29.7	10.0	8.6	58.4 / 23.0	140-200 / 63-90
155 W	1214	26.3	31.0 / 30.2	8.0	8.3	55.9 / 22.0	110-170 / 50-77
158 W	1244	26.5	31.4 / 30.6	8.0	8.5	55.9 / 22.0	130-190 / 59-86
161 W	1262	26.7	31.6 / 30.8	8.0	8.7	58.4 / 23.0	150-210 / 68-95

OVERVIEW

Tech Features

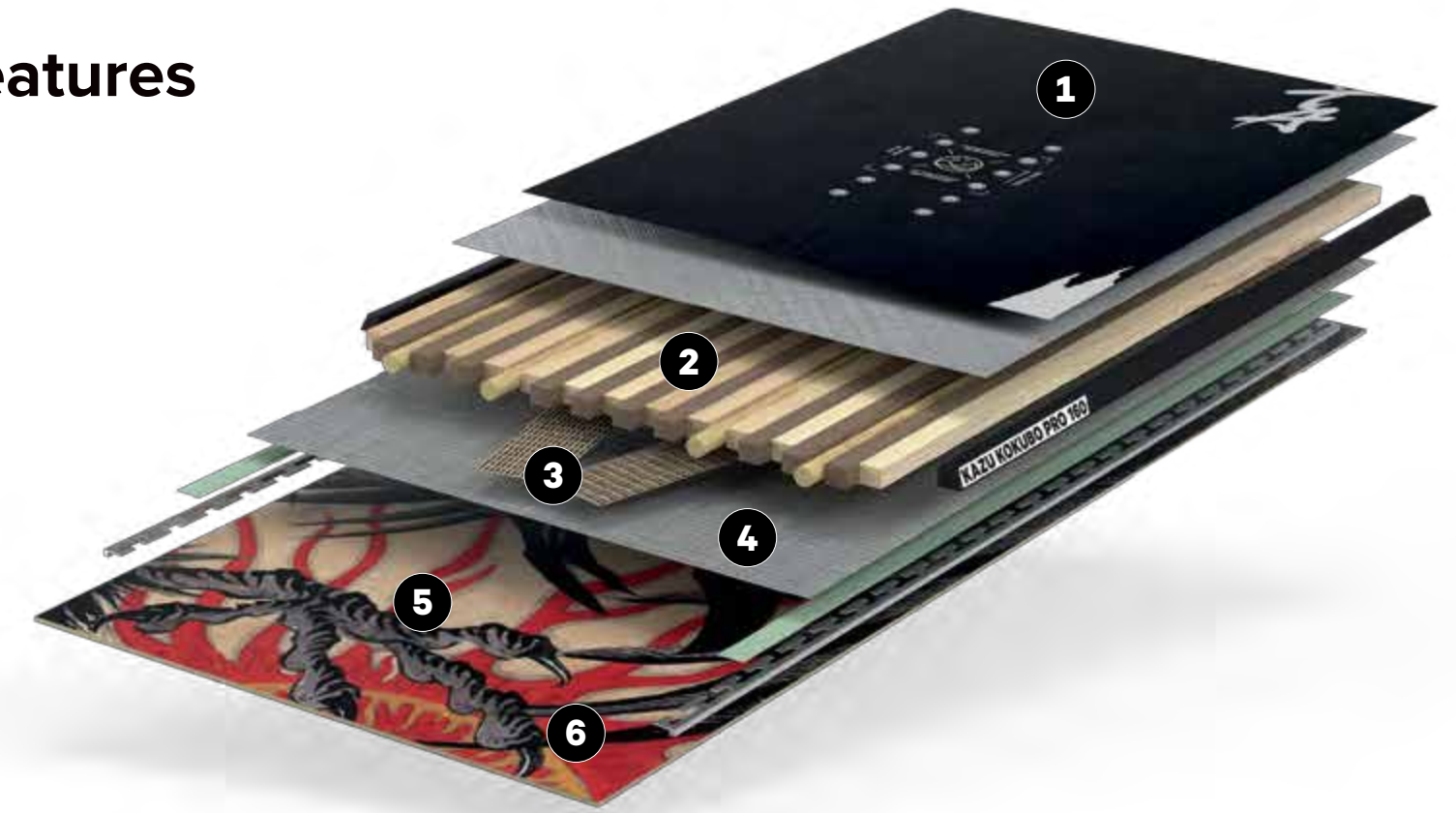

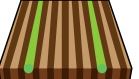

- 

1 TOPSHEET TECH:
SKINLESS™ CORE ASH WOODGRAIN TOPSHEET
• Digital Print
- 

2 CORE:
PANDA HOVER CORE™
- 





3 ADDITIVES:
4 x 25 mm CARBONFLAX™ AMPLIFIER
- 

4 GLASS + RESIN:
HOLYSHEET™ TRI/BI MAGIC BEAN™ RESIN
- 

5 BASE:
HYPERDRIVE™ ADV XT
• Sublimation
- 

6 BASE TECH:
MOONSHOT™ OMNI-TUNE™

CORE:

-  CARBONFLAX™
-  BAMBOO
-  PAULOWNIA
-  POPLAR



Quick and maneuverable, the *Kazu Pro's* lightweight power and pop comes from its Panda Hover Core™, CarbonFlax™ Amplifiers and a HolySheet™ Tri/Bi fiberglass configuration. Upgraded for 2025, the *Kazu Kokubo Pro* is now powered by a tougher HyperDrive™ ADV XT base with factory-direct Moonshot Omni-Tune™.

MERCURY



All-Mtn + Freeride / Directional / Hybrid Camber

The *Mercury* is your ticket to dominating every possible situation.

This award-winning series is renowned for its remarkable all-terrain versatility, excelling in powder, kickers, side hits, and park laps. With this board at your disposal, you won't need to obsessively check the weather report because it's ready to handle any condition and terrain you throw its way.



MERCURY

All-Mtn + Freeride / Directional / Hybrid Camber

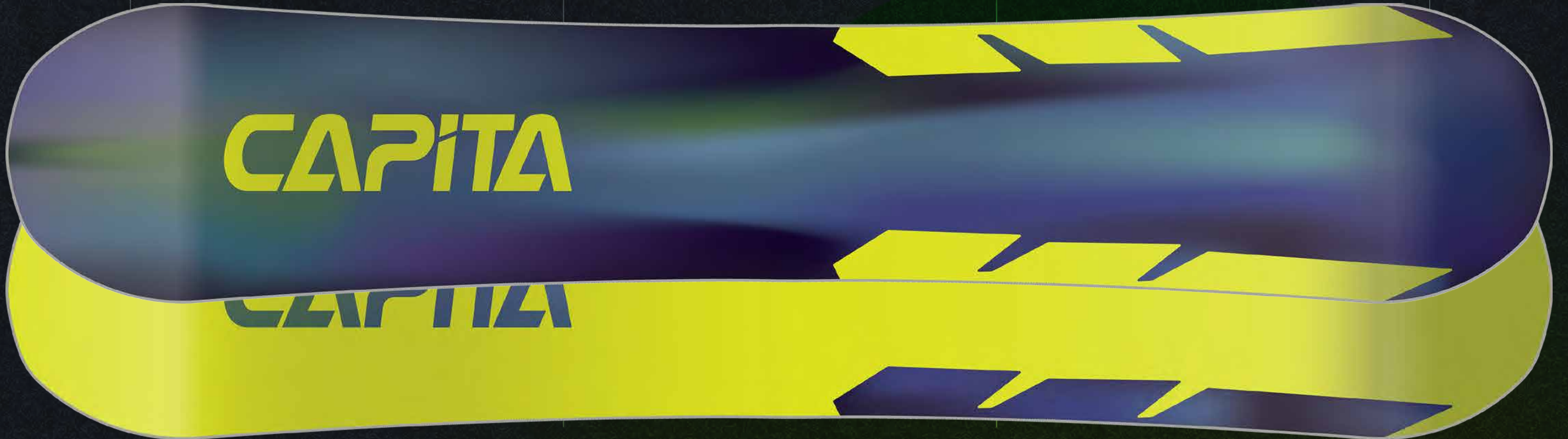

MERCURY



The new quiver killer. For the rider seeking one board to maximize all days.

RIDER TYPE:
All-Mtn / Freeride

SHAPE:
**Directional
0.5" Setback**

SIDECUT:
**New Age
Progressive
Death Grip™**

FLEX:
**Directional
6.5**

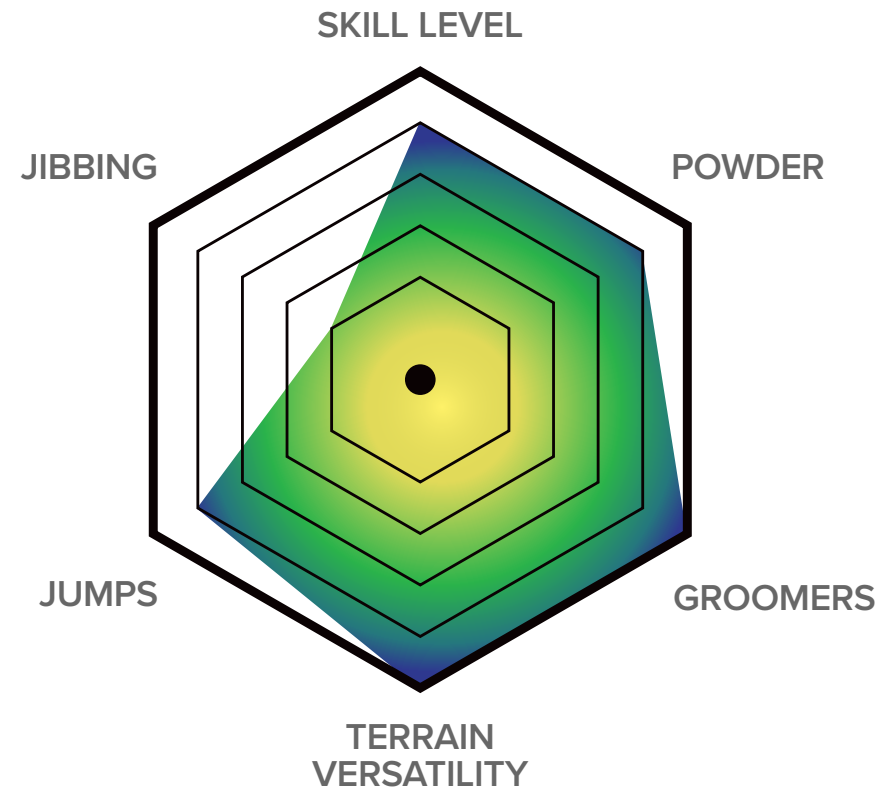

HYBRID CAMBER:
Resort V2 Directional + Flat Kick Tech

This revolutionary all-terrain shape provides the best of both worlds. It has a raised camber platform through the inserts to retain high-speed edge hold through variable terrain, elevated contact points to land and float in powder, and Flat Kick tip and tail arcs for faster, more aggressive transitions.

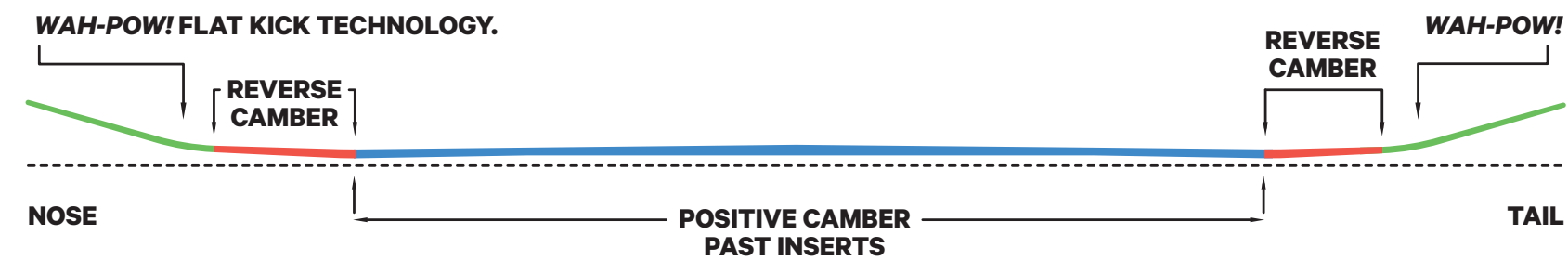

LENGTH	EFFECTIVE EDGE (mm)	WAIST	NOSE / TAIL	SIDECUT	REF. STANCE (cm / inches)	SUGGESTED WEIGHT (lbs / kg)
147	1135	24.8	29.1 / 29.1	7.1 / -1.5 / 7.1	50.8 / 20.0	80-140 / 36-63
150	1159	25.1	29.3 / 29.3	7.3 / -1.5 / 7.3	53.3 / 21.0	90-150 / 40-68
153	1183	25.3	29.6 / 29.6	7.5 / -1.5 / 7.5	53.3 / 21.0	100-160 / 45-72
155	1199	25.5	29.8 / 29.8	7.7 / -1.5 / 7.7	55.9 / 22.0	120-180 / 54-81
157	1215	25.7	30.1 / 30.1	7.8 / -1.5 / 7.8	55.9 / 22.0	130-190 / 59-86
159	1231	25.9	30.3 / 30.3	8.0 / -1.5 / 8.0	55.9 / 22.0	140-200 / 63-90
161	1247	26.1	30.5 / 30.5	8.1 / -1.5 / 8.1	58.4 / 23.0	160-220 / 72-99
156 W	1207	26.1	30.5 / 30.5	7.8 / -1.5 / 7.8	55.9 / 22.0	120-180 / 54-81
158 W	1223	26.3	30.7 / 30.7	7.9 / -1.5 / 7.9	55.9 / 22.0	130-190 / 59-86
160 W	1239	26.5	30.9 / 30.9	8.0 / -1.5 / 8.0	58.4 / 23.0	140-200 / 63-90
NEW! 162 W	1255	26.7	31.1 / 31.1	8.1 / -1.5 / 8.1	58.4 / 23.0	150-210 / 68-95

OVERVIEW

Tech Features

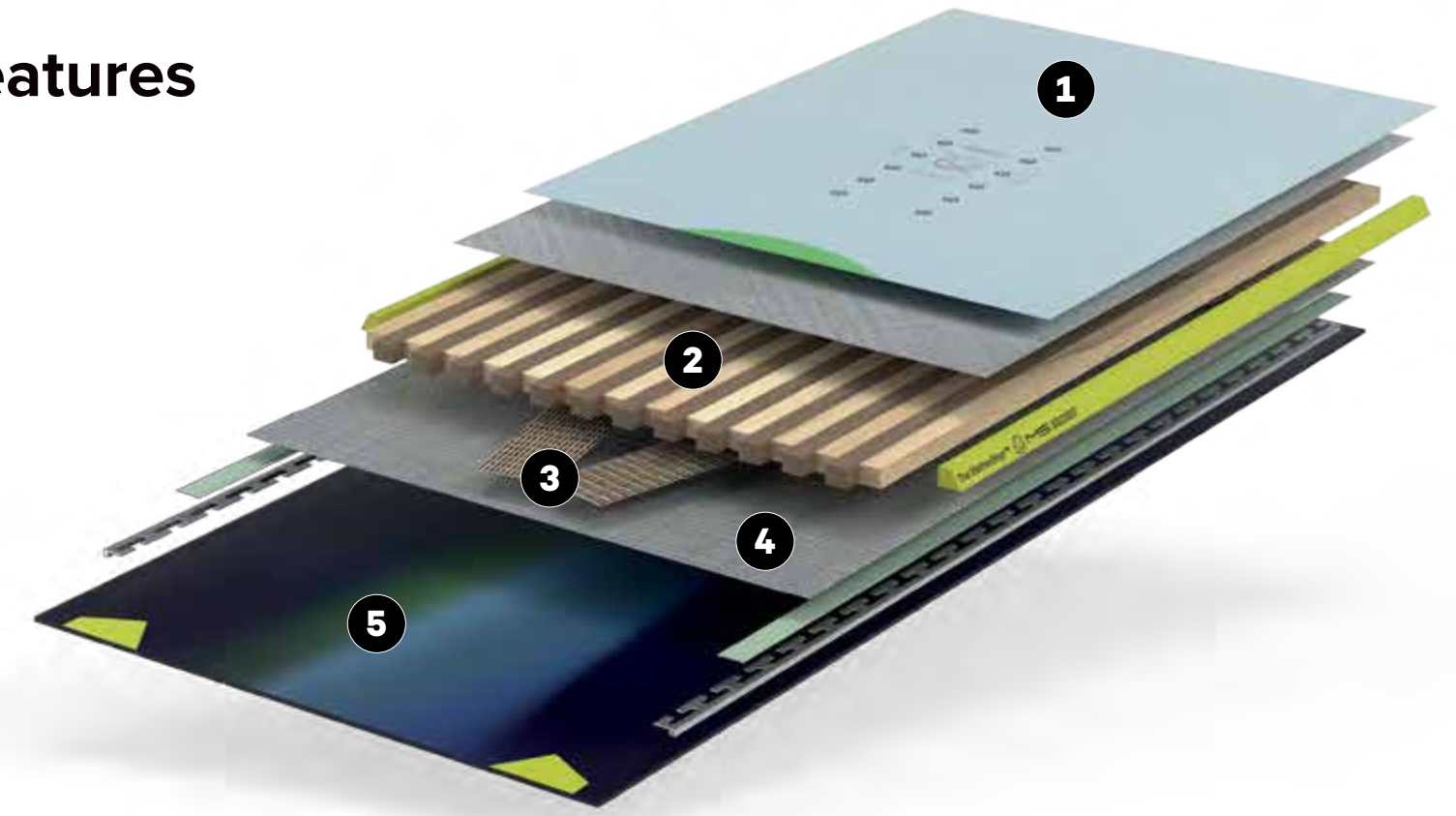

- 1** TOPSHEET TECH: **PLT Technology**
 - Digital + Screen
 - + Gloss/Matte Print
 - Pearlescent Underlay
- 2** CORE: **HOVER CORE™**
- 4** ADDITIVES: **4 x 25 mm CARBONFLAX™ AMPLIFIER**
- 4** GLASS + RESIN: **HOLYSHEET™ TRI/BI MAGIC BEAN™ RESIN**
- 5** BASE: **HYPERDRIVE™**
 - Die-cut + Sublimation
- **DEATH GRIP™ SIDECUT**

- CORE:
- CARBONFLAX™
 - PAULOWNIA
 - POPLAR

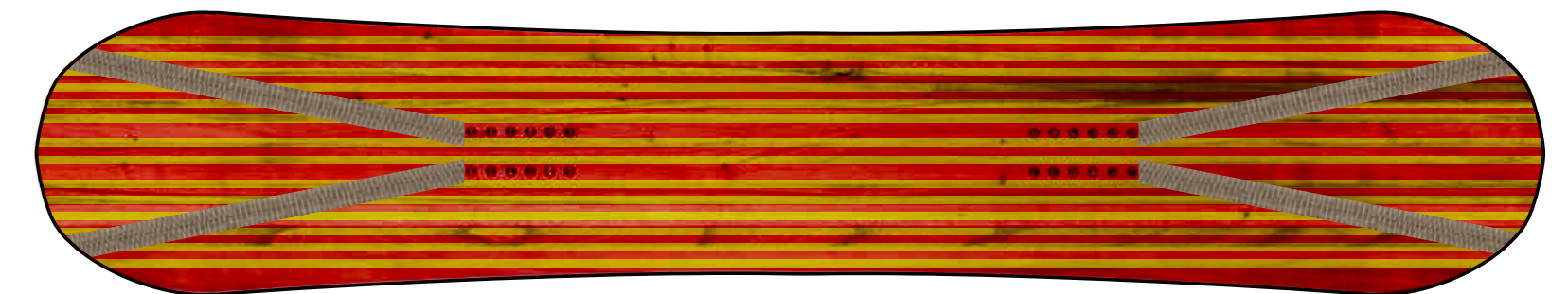

The *Mercury* is designed for power when you want it and float when you need it. Featuring a Hover Core™, CarbonFlax™ Amplifiers and a HolySheet™ Tri/Bi fiberglass configuration, the *Mercury's* durability and ollie power reign supreme.

THE NAVIGATOR

Powder + Resort / Directional / Hybrid Camber

Riding powder is like hiking into a backcountry camping trip. Once you're past the trailhead, if you have the right gear, there's nothing better. If you packed the wrong kit, there's nothing worse. The Navigator is your fire starter; it is your unwavering compass. It is essential to the experience.

This powder-annihilating series features a parabolic sidecut and a sinking tapered tail to swim through the soft stuff while the wide-frame rockered nose naturally floats above deep snow. The resulting shape transforms tiring powder days into emotionally fulfilling outdoor experiences.

NAVIGATOR WMN

Women's / Powder + Resort / Directional / Hybrid Camber



NAVIGATOR WMN

Women's / Powder + Resort / Directional / Hybrid Camber



145

147

151

BASE

NAVIGATOR

Powder + Resort / Directional / Hybrid Camber



NAVIGATOR

Powder + Resort / Directional / Hybrid Camber



155



158



161



164



167



BASE

NAVIGATOR



The perfect series for side-country and resort powder annihilators.

RIDER TYPE:
Powder / Resort

SHAPE:
**Directional
0.8" Set Back**

SIDECUT:
**Parabolic
Radical Taper**

FLEX:
**Directional
5.5**

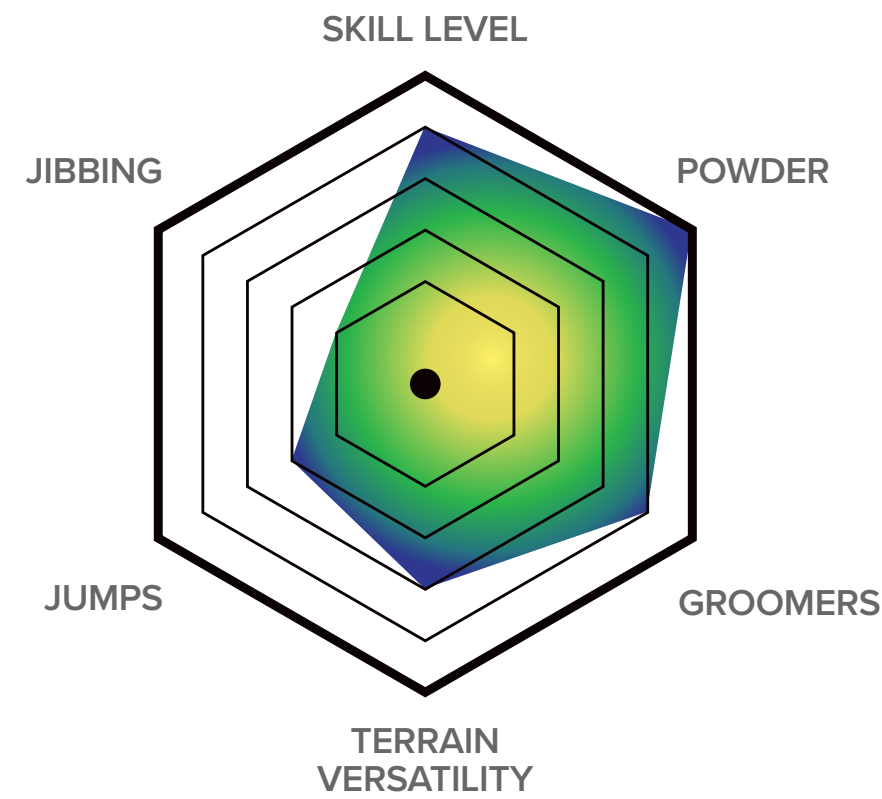

HYBRID CAMBER:
Resort V2 Directional + Flat Kick Tech

This revolutionary all-terrain shape provides the best of both worlds. It has a raised camber platform through the inserts to retain high-speed edge hold through variable terrain, elevated contact points to land and float in powder, and Flat Kick tip and tail arcs for faster, more aggressive transitions.

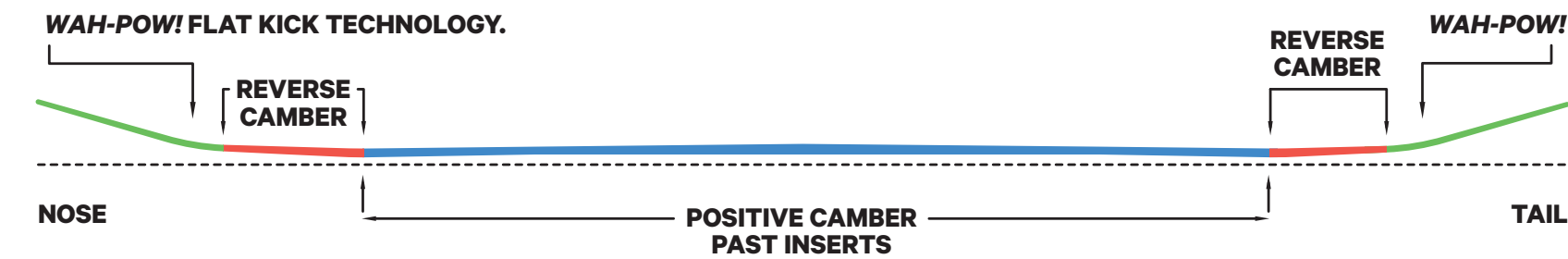

LENGTH	EFFECTIVE EDGE (mm)	WAIST	NOSE / TAIL	TAPER	SIDECUT	REF. STANCE (cm / inches)	SUGGESTED WEIGHT (lbs / kg)
143 WMN	1077	24.0	28.4 / 27.7	7.0	7.1 / 6.0 / 7.1	48.3 / 19.0	80-130 / 36-58
147 WMN	1107	24.1	28.7 / 27.8	8.8	7.3 / 6.2 / 7.3	50.8 / 20.0	90-140 / 40-63
151 WMN	1135	24.5	29.3 / 28.3	9.8	7.5 / 6.4 / 7.5	53.3 / 21.0	110-160 / 59-73
155	1169	25.2	30.1 / 29.0	11.6	8.0 / 6.8 / 8.0	53.3 / 21.0	130-190 / 59-86
158	1192	25.6	30.5 / 29.3	11.8	8.1 / 7.0 / 8.1	55.9 / 22.0	150-200 / 68-90
161	1216	26.0	31.0 / 29.7	12.9	8.3 / 7.2 / 8.3	58.4 / 23.0	160-210 / 72-95
164	1229	26.4	31.5 / 30.1	13.9	8.5 / 7.4 / 8.5	58.4 / 23.0	170-220 / 77-100
167	1249	26.8	32.2 / 30.7	14.9	8.7 / 7.6 / 8.7	58.4 / 23.0	180-230 / 81-104

OVERVIEW

Tech Features

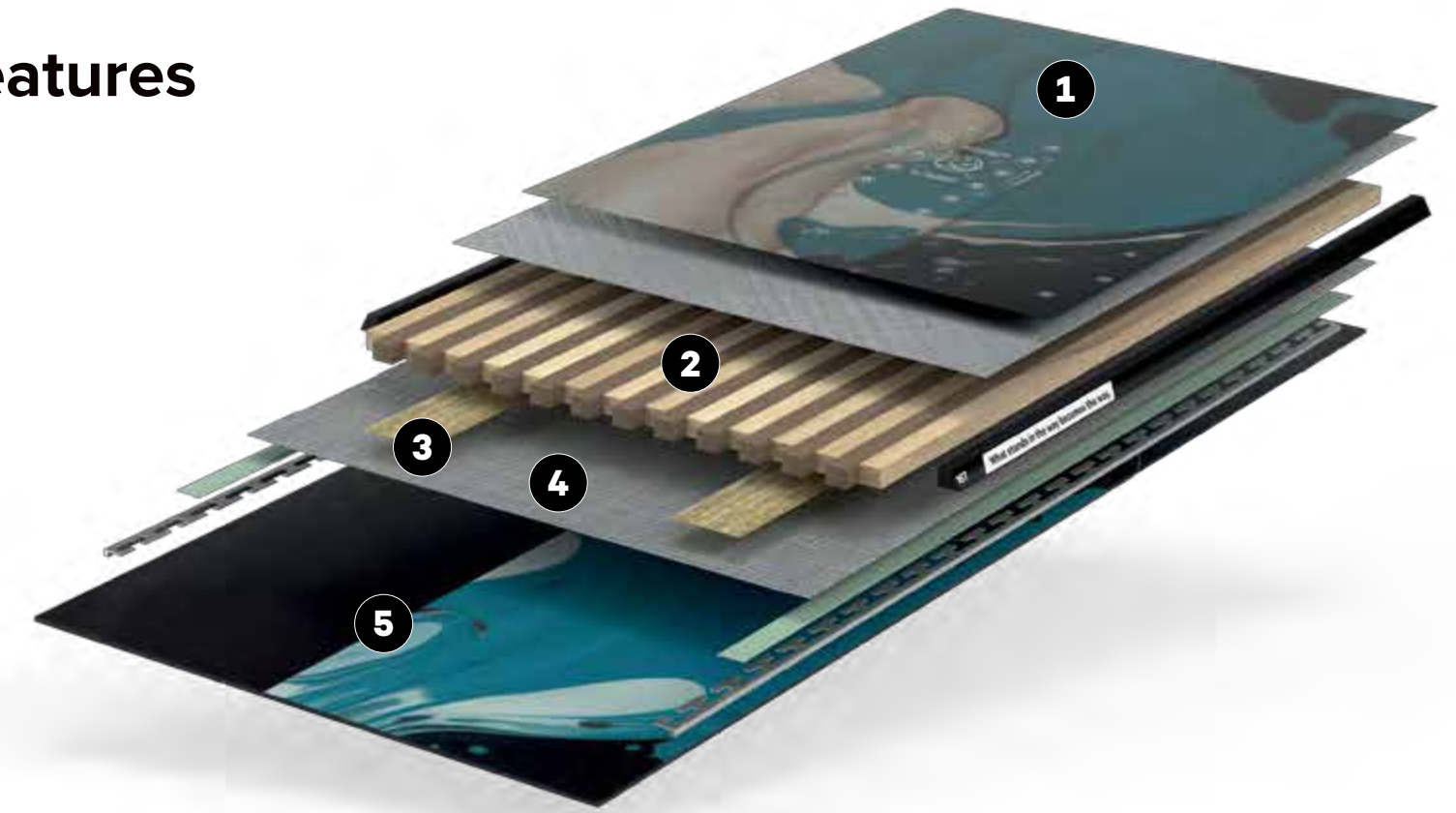

- 1** TOPSHEET TECH: SKINLESS™ CORE ASH WOODGRAIN TOPSHEET • Digital Print
- 2** CORE: HOVER CORE™
- 3** ADDITIVES: 2 x 30 mm TECHNORA™ FLAX BOOSTERS

- 4** GLASS + RESIN: HOLYSHEET™ TRI/BI MAGIC BEAN™ RESIN
- 5** BASE: HYPERDRIVE™ • Die-cut + Sublimation

- CORE:
- TECHNORA™ FLAX
 - PAULOWNIA
 - POPLAR



The *Navigator* achieves its playful nature that riders worldwide have grown to love from its Hover Core™ with Technora™ Flax Boosters. For 2025, the *Navigator* series has also been upgraded with a new HyperDrive™ high speed sintered base.

NAVIGATOR SPLIT

Split Board / Powder + Resort / Directional
Hybrid Camber

The *Navigator*, known as a powder-annihilating favorite of the CAPiTA collection is again available in a factory-direct split. This side-country slayer will help unlock worlds of new terrain out of bounds or access a skin up your favorite resort line when uphill travel is allowed.

This series provides lightweight, controlled ascents with camber underfoot, and endless float and smooth turns on the descent thanks to its sinking tapered tail and parabolic sidecut.

The *Navigator Split* is a value-drive tool for unlocking endless pow stashes and epic-level experiences.



NAVIGATOR WMN SPLIT

Split Board / Women's / Powder + Resort / Directional / Hybrid Camber

HANDCRAFTED WITH SELF-GENERATED CLEAN ENERGY
AT THE CAPiTA MOTHERSHIP

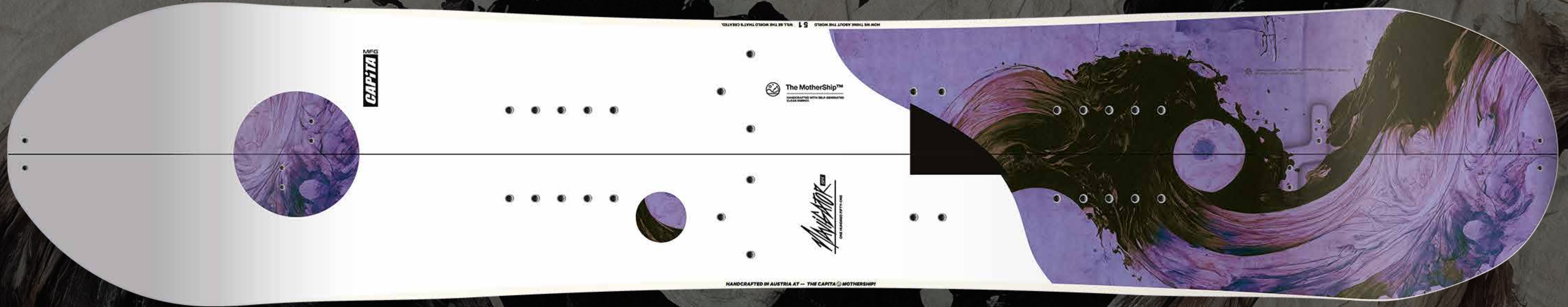

NAVIGATOR WMN SPLIT

Split Board / Women's / Powder + Resort / Directional / Hybrid Camber

HANDCRAFTED WITH SELF-GENERATED CLEAN ENERGY
AT THE CAPITA MOTHERSHIP



147

151

BASE

NAVIGATOR SPLIT

Split Board / Powder + Resort / Directional / Hybrid Camber

HANDCRAFTED WITH SELF-GENERATED CLEAN ENERGY AT THE CAPITA MOTHERSHIP

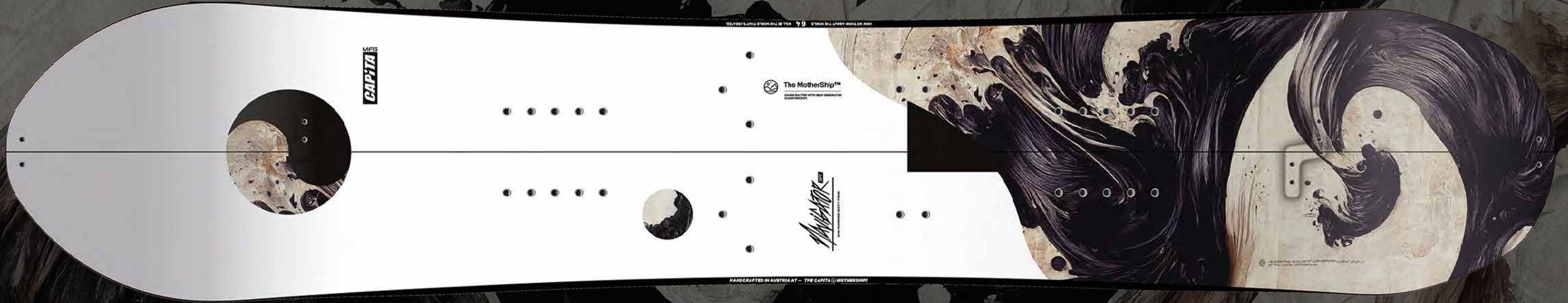

NAVIGATOR SPLIT

Split Board / Powder + Resort / Directional / Hybrid Camber

HANDCRAFTED WITH SELF-GENERATED CLEAN ENERGY AT THE CAPITA MOTHERSHIP



155

158

161

164

BASE

NAVIGATOR SPLIT



The value driven split option for sidecountry missions near and far.

RIDER TYPE:
Powder Seeker

SHAPE:
Directional
0.8" Set Back

SIDECUT:
Parabolic
Radical Taper

FLEX:
Directional
6

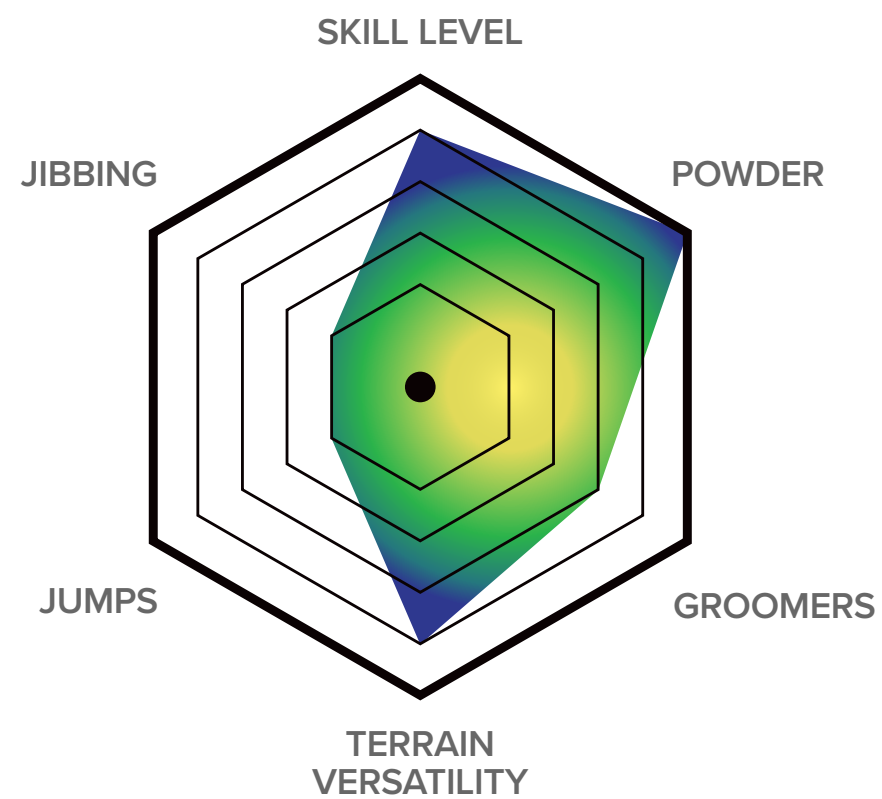

HYBRID CAMBER:
Resort V2 Directional + Flat Kick Tech

This revolutionary all-terrain shape provides the best of both worlds. It has a raised camber platform through the inserts to retain high-speed edge hold through variable terrain, elevated contact points to land and float in powder, and Flat Kick tip and tail arcs for faster, more aggressive transitions.

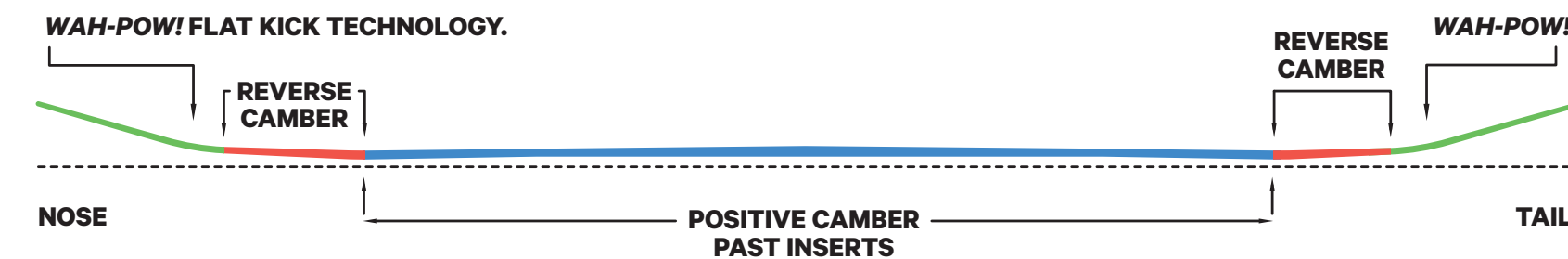

LENGTH	EFFECTIVE EDGE (mm)	WAIST	NOSE / TAIL	TAPER	SIDECUT	REF. STANCE (cm / inches)	SUGGESTED WEIGHT (lbs / kg)
147 WMN	1110	24.1	28.7 / 27.8	8.8	7.3 / 6.2 / 7.3	50.8 / 20.0	90-140 / 40-63
151 WMN	1140	24.5	29.3 / 28.3	9.8	7.5 / 6.4 / 7.5	53.3 / 21.0	110-160 / 59-73
155	1182	25.2	30.1 / 29.0	11.6	8.0 / 6.8 / 8.0	53.3 / 21.0	130-190 / 59-86
158	1195	25.6	30.5 / 29.3	11.8	8.1 / 7.0 / 8.1	55.9 / 22.0	150-200 / 68-90
161	1222	26.0	31.0 / 29.7	12.9	8.3 / 7.2 / 8.3	58.4 / 23.0	160-210 / 72-95
164	1238	26.4	31.5 / 30.1	13.9	8.5 / 7.4 / 8.5	58.4 / 23.0	170-220+ / 77-100+

OVERVIEW

Tech Features



1 TOPSHEET TECH:
• Digital Print
• Metallic Underlay

2 CORE:
NEW!
3D ASCEND 2
SPLIT CORE™

3 ADDITIVES:
2 x 30 mm
TECHNORA™ FLAX
BOOSTERS

4 GLASS + RESIN:
HOLYSHEET™ TRI/TRI
MAGIC BEAN™ RESIN

5 BASE:
NEW!
HYPERDRIVE™
• Die-cut + Digital Print

6 EXPEDITION SKINS
UNION BINDING COMPANY MONTANA
INCLUDED:
• UNION EXPEDITION SKINS
BY MONTANA™
• UNION PRO CLIPS
AND HOOKS

CORE:
■ TECHNORA™ FLAX
■ BEECH
■ POPLAR



This series combines incredible performance with its Ascend 2 Split Core™, Technora™ Flax Boosters and a new HyperDrive™ base while its value is unmatched as it comes factory direct with Union Expedition Skins by Montana™ and Union Pro Clips and Hooks.

THE EQUALIZER

With Jess Kimura
Women's / All-Mtn + Freeride / Directional /
Hybrid Camber

Inspired by *Jess Kimura's* progression from the streets to the backcountry, *The Equalizer* was born to level the playing field on the mountain and offer riders a high-end all-mountain option designed specifically for women.

The series now features an updated custom designed hybrid camber profile, providing positive camber through the length of the board for carving control, while reverse camber in the nose and tail maximizes float in powder.

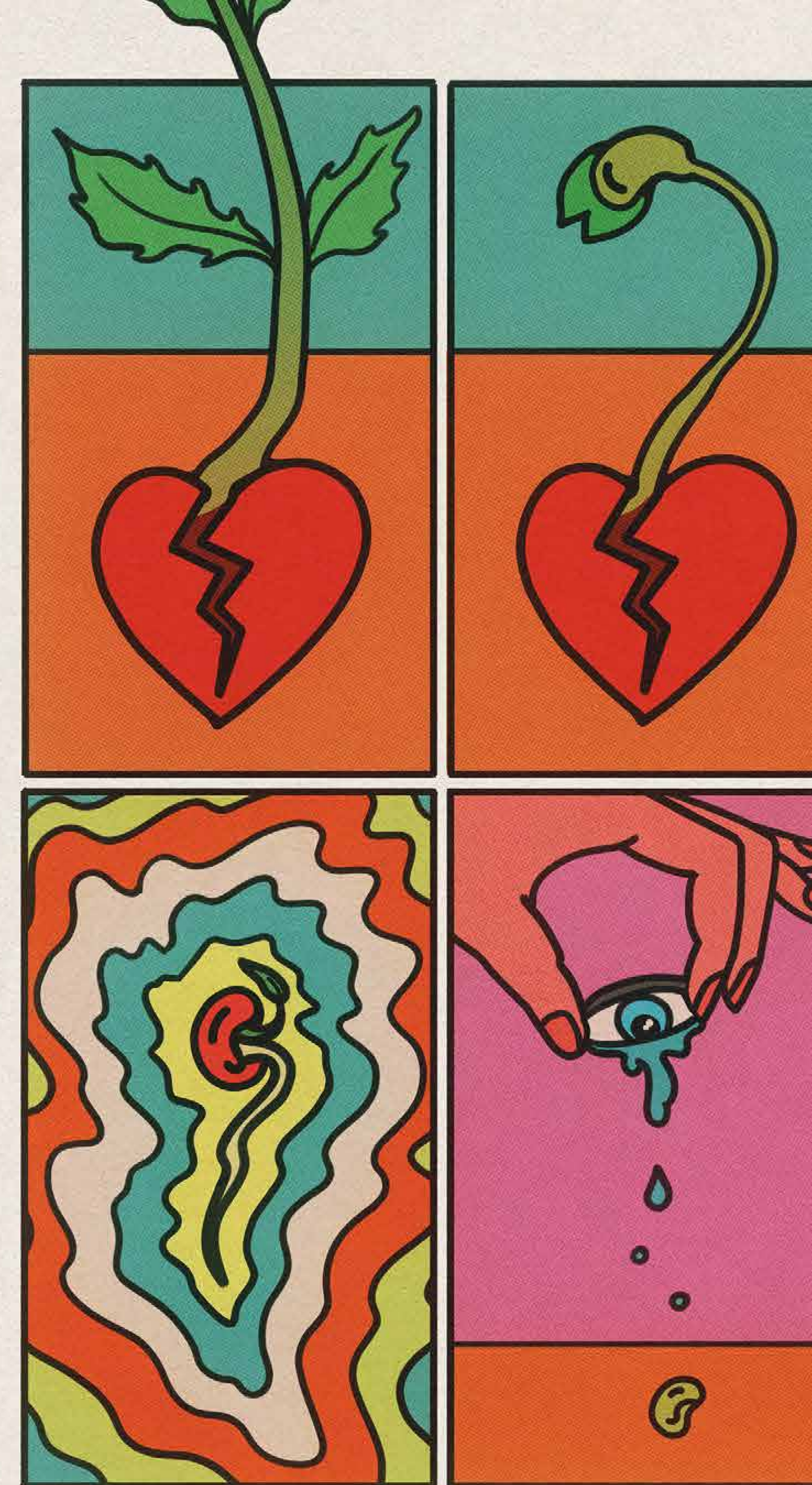

THE EQUALIZER

BY JESS KIMURA

Women's / All-Mtn + Freeride / Directional / Hybrid Camber



THE EQUALIZER

BY JESS KIMURA

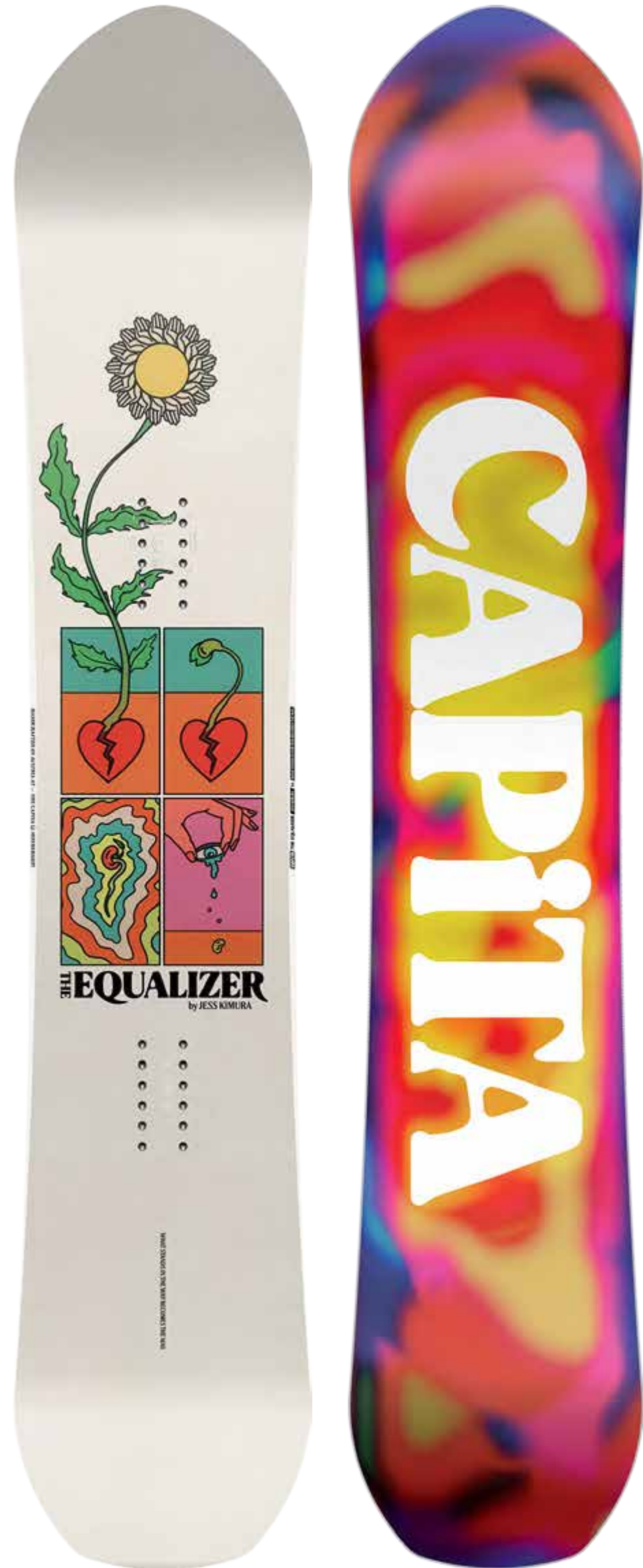

For the inspired rider looking to unlock all possible terrain.

RIDER TYPE:
All-Mtn / Freeride

SHAPE:
Directional
0.8" Set Back

SIDECUT:
Blended Radial

FLEX:
Directional
5.5

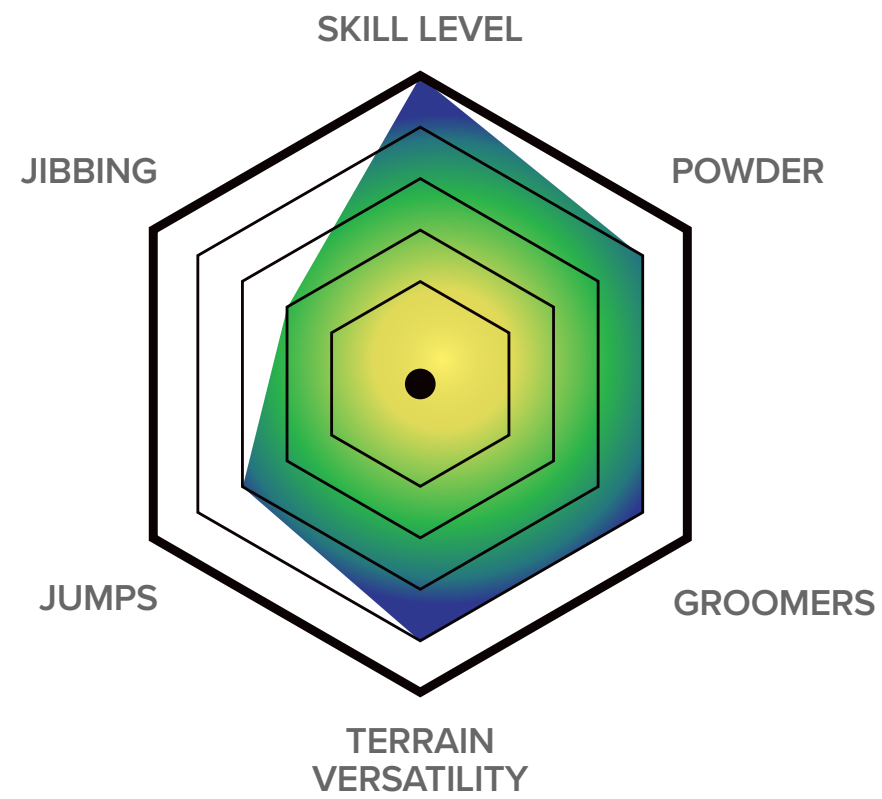

HYBRID CAMBER:
Resort V2 Directional + Flat Kick Tech

This revolutionary all-terrain shape provides the best of both worlds. It has a raised camber platform through the inserts to retain high-speed edge hold through variable terrain, elevated contact points to land and float in powder, and Flat Kick tip and tail arcs for faster, more aggressive transitions.

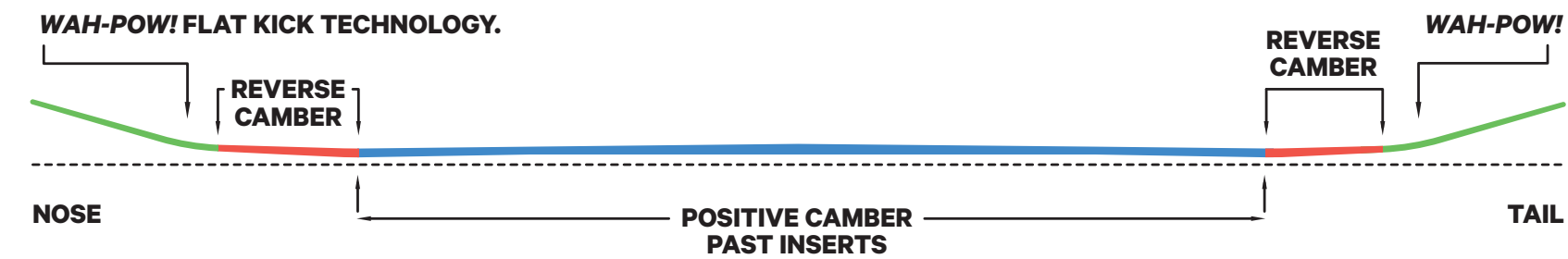

LENGTH	EFFECTIVE EDGE (mm)	WAIST	NOSE / TAIL	SIDECUT	REF. STANCE (cm / inches)	SUGGESTED WEIGHT (lbs / kg)
142	1103	22.9	27.3 / 27.1	6.8	48.3 / 19.0	90-140 / 41-64
146	1141	23.5	27.9 / 27.8	7.2	50.8 / 20.0	100-150 / 45-68
150	1166	24.1	28.5 / 28.4	7.6	50.8 / 20.0	110-170 / 50-77
154	1206	24.7	29.1 / 29.0	8.0	53.3 / 21.0	120-190 / 55-86

OVERVIEW

Tech Features

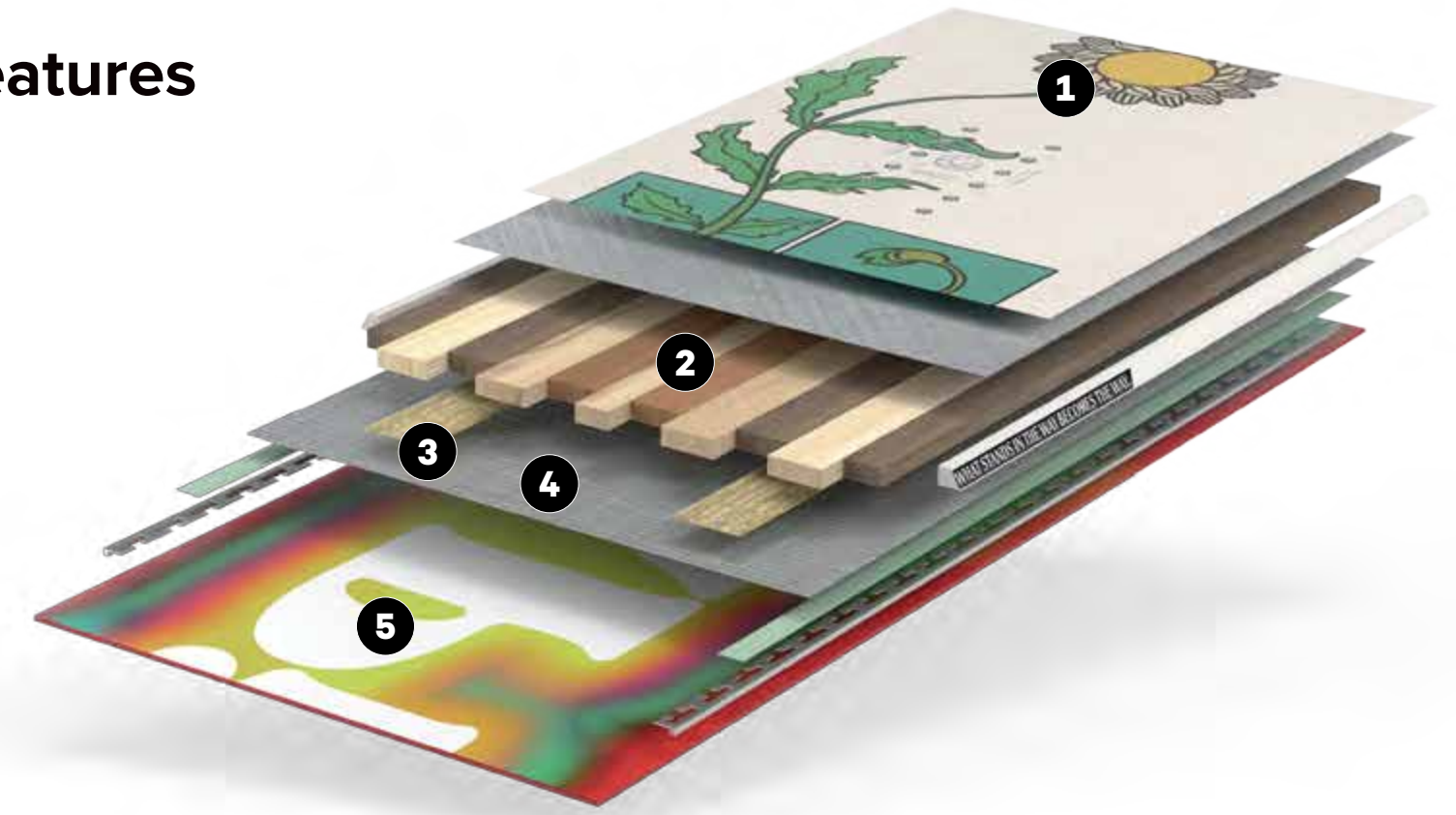

1 TOPSHEET TECH:
PLT Technology

- Digital + Gloss/Matte Print
- Pearlescent Underlay

2 CORE:
META CORE™

3 ADDITIVES:
2 x 30 mm TECHNORA™ FLAX BOOSTERS

4 GLASS + RESIN:
HOLYSHEET™ TRI/BI
MAGIC BEAN™ RESIN

5 BASE:
QUANTUM DRIVE™
• Sublimation

CORE:

- TECHNORA™ FLAX
- BEECH
- PAULOWNIA
- POPLAR

The Equalizer's ride and response comes from its META Core™ to achieve a desirable flex for all-mountain terrain, while Technora™ Flax Boosters provides longitudinal power. Featuring a Quantum Drive™ high-speed sintered base, The Equalizer is one of the most technically advanced women's freeride boards on the market.

HEY YOU T H

CO

FF



YOLOUTHER



CHILDREN OF THE POW



CHILDREN OF THE GNAR



JESS KIMURA MINI



SCOTT STEVENS MINI



MICRO MINI

CHILDREN OF THE POW

Youth / Powder + Resort / Directional / Reverse Camber

The *Children of the Pow* is designed as a powder-specific youth board for the next generation.

It is specifically for the 'tween-age' young guns ready to seek side-country slashes and epic pow stashes; it's for younger riders who want more float and a board designed for powder.

With a progressive shape, and a camber profile inspired by the notorious Spring Break Snowboards series, the *Children of the Pow* will open worlds of new terrain for young shredders during those in-between years.



CHILDREN OF THE POW

Youth / Powder + Resort / Directional / Reverse Camber



CHILDREN OF THE POW

Youth / Resort + Park / True Twin / Hybrid Camber



130



BASE



135



BASE



140



BASE



CHILDREN OF THE POW



For mountain children who live among the powder hounds.

RIDER TYPE:
Powder / Resort

SHAPE:
**Directional Twin
0.8" Set Back**

SIDECUT:
Blended Radial

FLEX:
**Directional
3.5**

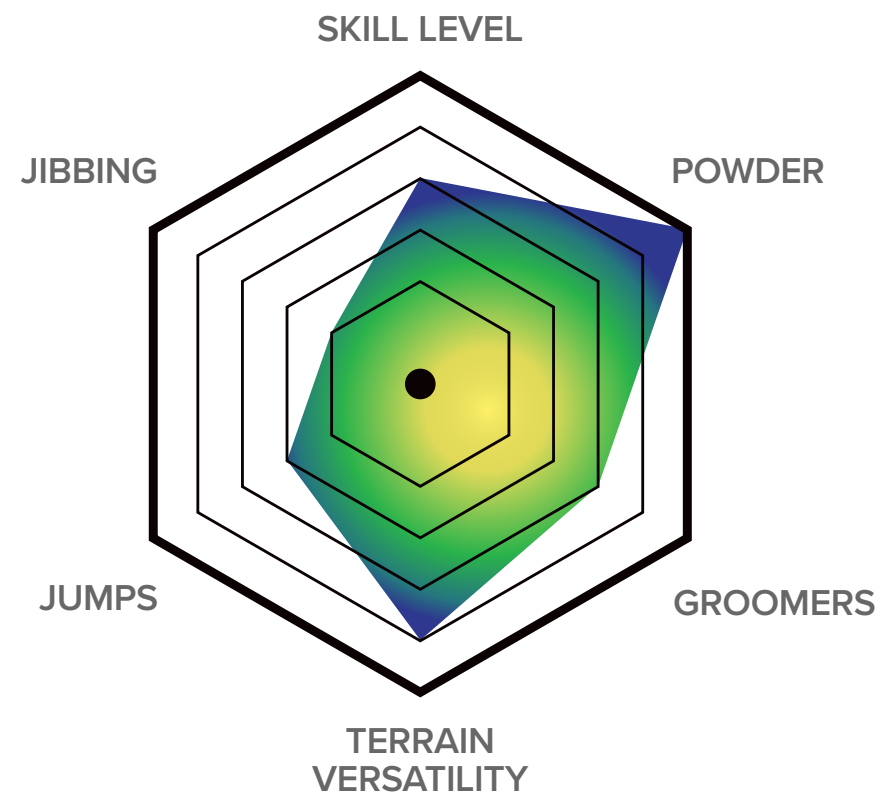

REVERSE CAMBER:
Surf Rocker

The *SURF ROCKER* features a continuous arching tip and tail inspired by the modern design of many of today's best surfboards: flat through the inserts with smooth arching tip and tails. The gentle low angle allows for maximum float and control.



LENGTH	EFFECTIVE EDGE (mm)	WAIST	NOSE / TAIL	TAPER	SIDECUT	REF. STANCE (cm / inches)	SUGGESTED WEIGHT (lbs / kg)
130	891	24.6	29.0 / 27.0	20.0	5.7	43.2 / 17.0	70-105 / 31-47
135	924	25.1	29.5 / 27.5	20.0	6.2	45.7 / 18.0	80-115 / 36-52
140	957	25.6	30.0 / 28.0	20.0	6.7	48.3 / 19.0	90-135 / 41-61

OVERVIEW

Tech Features

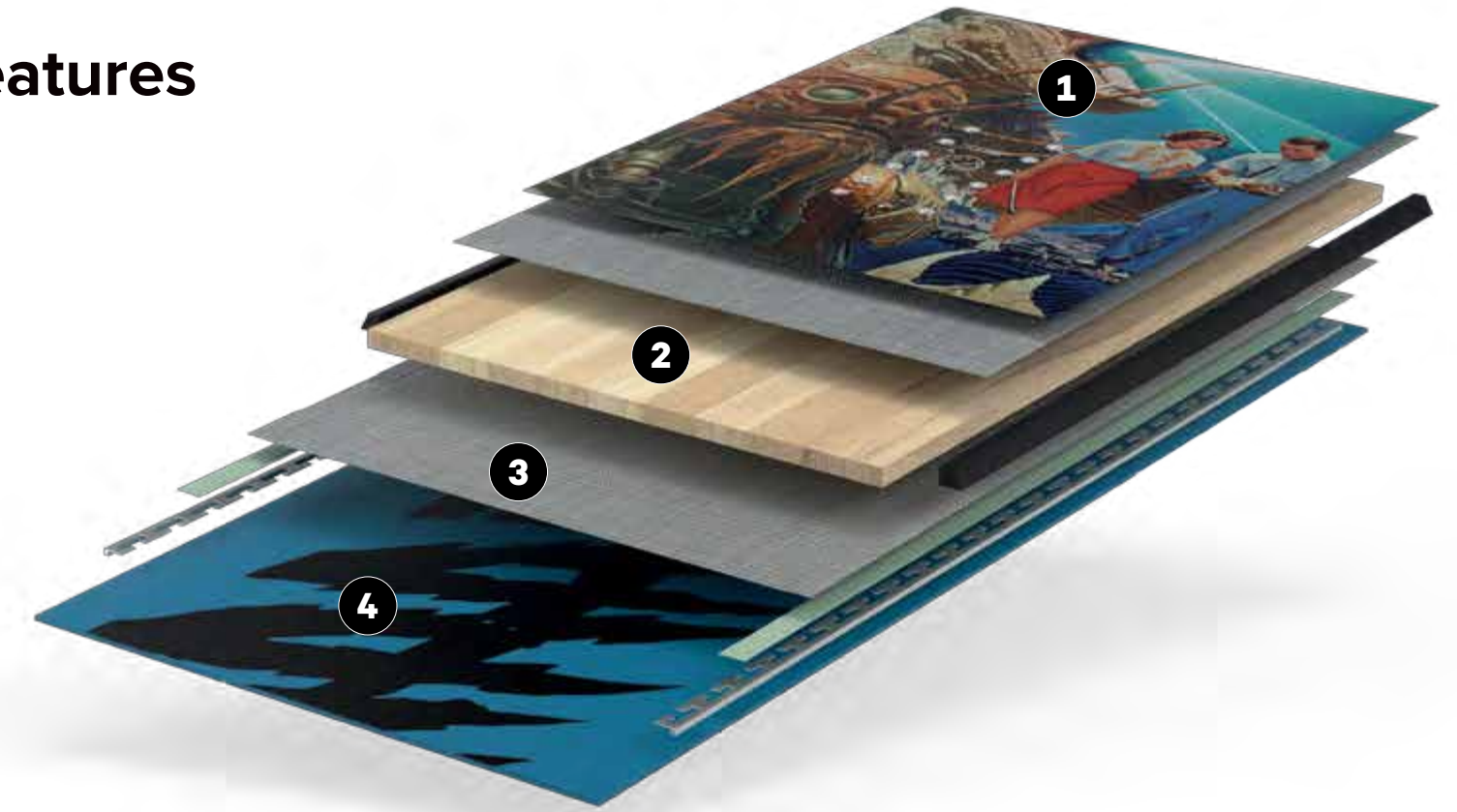

1 TOPSHEET TECH:
• Digital Print

2 CORE:
SELECT 2.0 CORE™

3 GLASS + RESIN:
NEW!
SPECIAL BLEND FIBERGLASS
MAGIC BEAN™ RESIN

4 BASE:
XXX[TRUDED]™
• Sublimation

CORE:
■ POPLAR

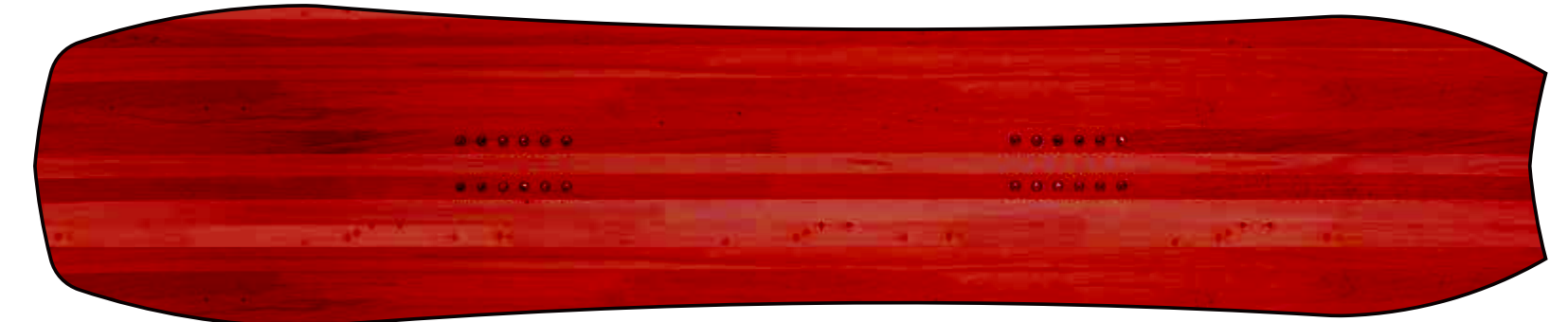

The *Children Of The Pow* provides ultimate floatation and glide thanks to its Surf Rocker profile combined with the Select 2.0 Core™, and a fast, yet easy to maintain XXX[TRUDED]™ Base, upgraded with Special Blend Fiberglass for 2025.

CHILDREN OF THE GNAR

Youth / Resort + Park / True Twin / Hybrid Camber

Designed as a “tween-age” destroyer, these boards form a bridge between the boys and men. It’s here where the kids start riding better than their parents if that hasn’t happened already.

Although this series is very forgiving and promotes skill-building, it is no toy. The *Children of the Gnar* is the go-anywhere, do-anything freestyle deck for young shredders during those in-between years.



CHILDREN OF THE GNAR

Youth / Resort + Park / True Twin / Hybrid Camber



CHILDREN OF THE GNAR

Youth / Resort + Park / True Twin / Hybrid Camber



137



BASE



141



BASE



145



BASE

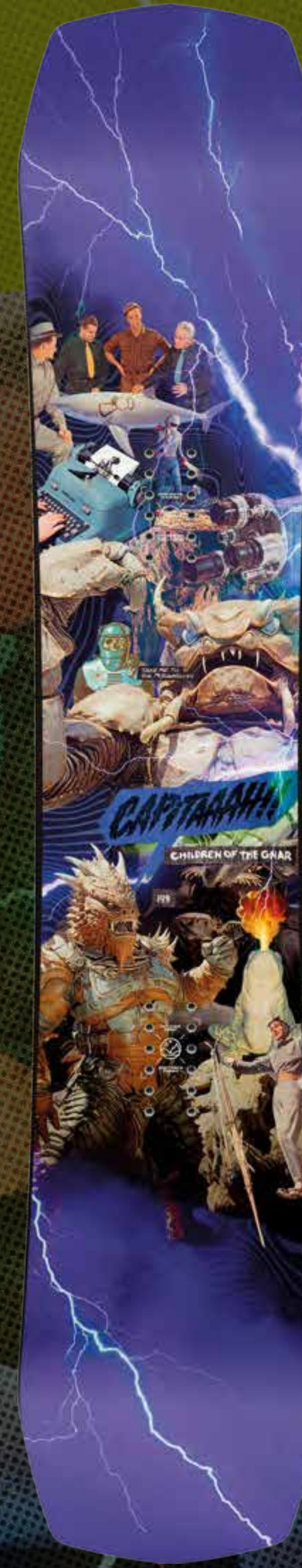

149



BASE

CHILDREN OF THE GNAR



A resort and park board for the next-generation youth ready to progress their riding to new heights.

RIDER TYPE:
Resort / Park

SHAPE:
True Twin

SIDECUT:
Blended Radial

FLEX:
Twin 3.5

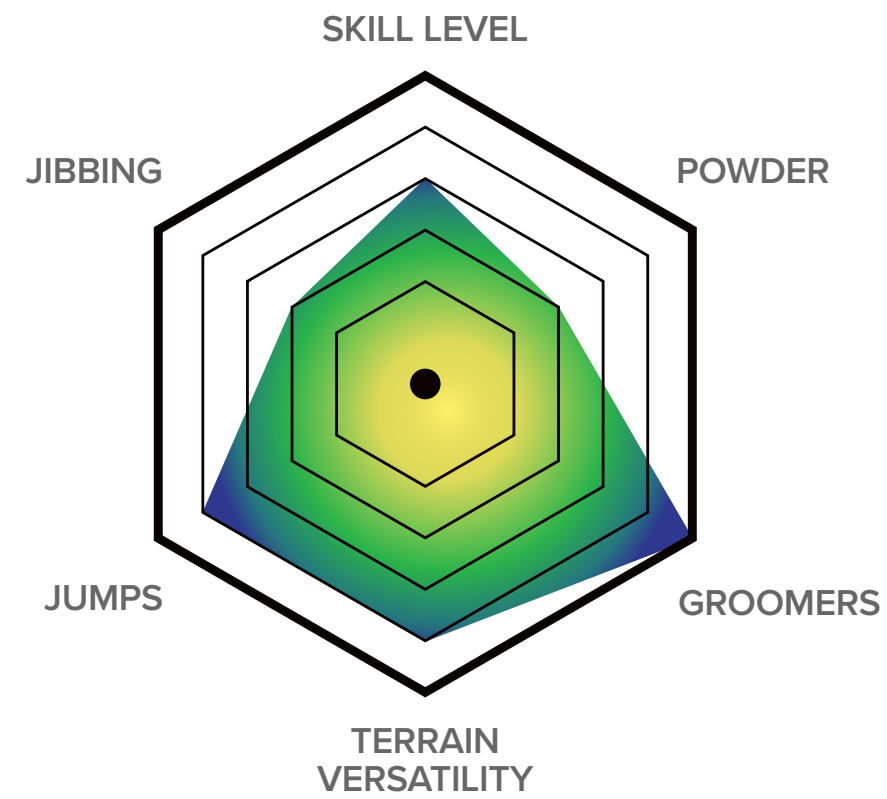

HYBRID CAMBER:
Resort V1 + Flat Kick Tech

Our *RESORT V1 Profile* boards take full advantage of the benefits of traditional camber, zero camber, and reverse camber. This next generation design allows you to get the pop and response of a cambered board with all the predictability and easy turn initiation of zero camber or reverse camber shapes.

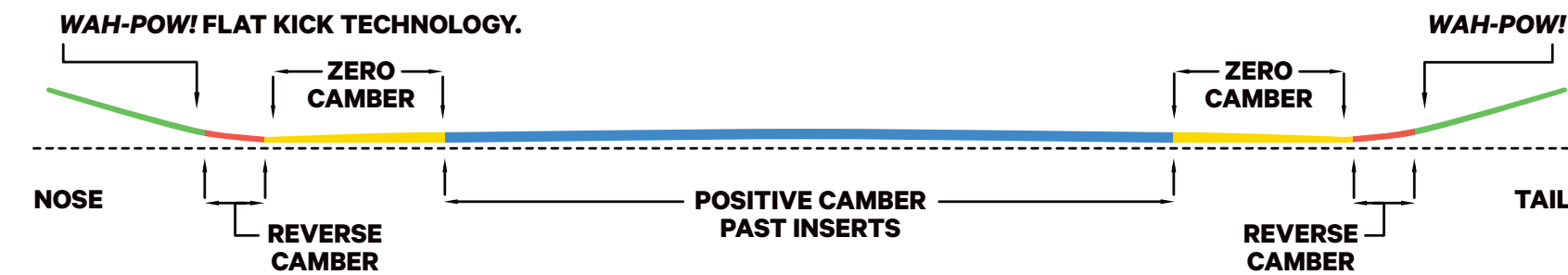

LENGTH	EFFECTIVE EDGE (mm)	WAIST	NOSE / TAIL	SIDECUT	REF. STANCE (cm / inches)	SUGGESTED WEIGHT (lbs / kg)
137	1054	23.8	28.0 / 28.0	6.3	45.7 / 18.0	70-100 / 32-45
141	1089	24.1	28.3 / 28.3	6.7	48.3 / 19.0	80-110 / 36-50
145	1124	24.4	28.7 / 28.7	7.1	50.8 / 20.0	90-130 / 41-59
149	1159	24.7	29.0 / 29.0	7.5	50.8 / 20.0	100-140 / 45-64

OVERVIEW

Tech Features

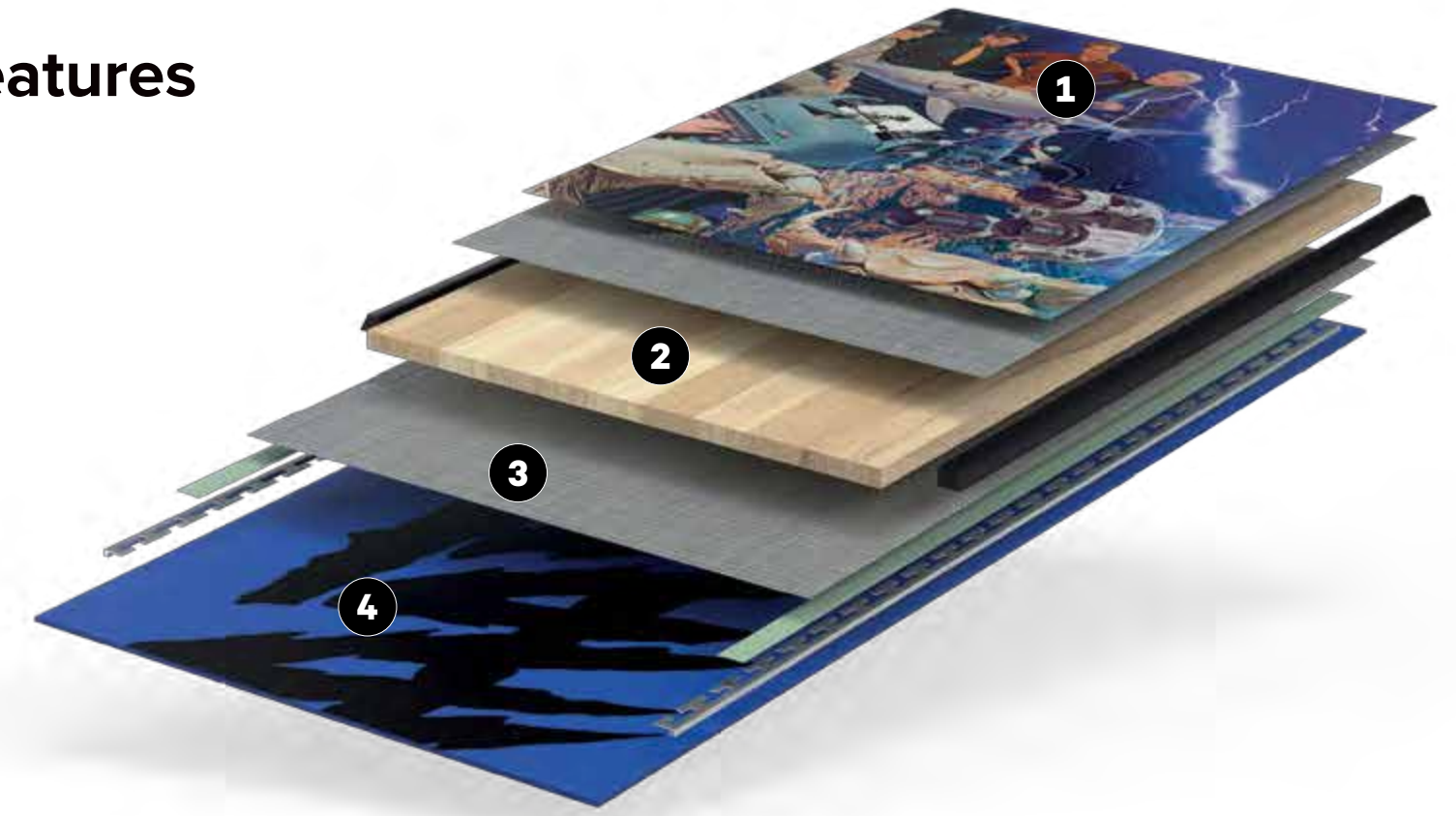

1 TOPSHEET TECH:
• Digital Print

2 CORE:
SELECT 2.0 CORE™

3 GLASS + RESIN:
NEW!
SPECIAL BLEND FIBERGLASS
MAGIC BEAN™ RESIN

4 BASE:
XXX[TRUDED]™
• Die-cut

CORE:
POPLAR



With a camber profile inspired by the award winning D.O.A. series and a Select Core 2.0™ in combination with an upgraded Special Blend Fiberglass and a fast, yet easy to maintain XXX[TRUDED]™ base, the *Children of the Gnar* has the power, pop and durability required for progressive youth riders.

JESS KIMURA MINI

Youth / Resort + Park / True Twin / Reverse Camber

Back again, the *Jess Kimura Mini* is the mini-shred rad girl model designed to bridge the gap between the Micro Mini and the smallest sizes of the mainline ladies' boards.

Produced at The MotherShip™ utilizing clean energy while featuring reforestation-certified sustainable woodcores, these boards are packed with technology at a price parents can afford.

Snappy, soft, and designed with a slight reverse camber and beveled shape, they're everything you've come to expect from a *CAPiTA* in a simplified, scaled-down form.



JESS KIMURA MINI

Youth / Resort + Park / True Twin / Reverse Camber



CAPITA

JESS KIMURA MINI



Catch-free riding for girls looking to progress during their early years of snowboarding.

RIDER TYPE:
Resort / Park

SHAPE:
True Twin

SIDECUT:
Radial

FLEX:
Twin 3

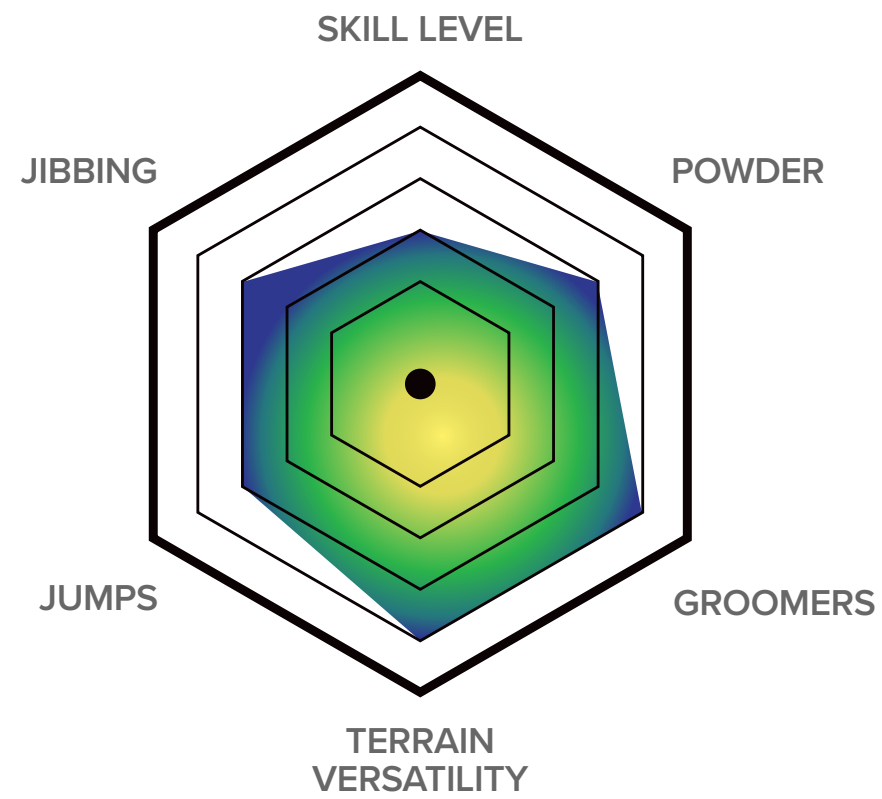

REVERSE CAMBER:
Park Mini

Rockered and beveled for catch free riding.



LENGTH	EFFECTIVE EDGE (mm)	WAIST	NOSE / TAIL	SIDECUT	REF. STANCE (cm / inches)	SUGGESTED WEIGHT (lbs / kg)
115	880	22.1	25.5 / 25.5	5.3	38.1 / 15.0	50-65 / 22-29
120	929	22.5	26.1 / 26.1	5.6	43.2 / 17.0	55-70 / 25-32
125	958	22.9	26.6 / 26.6	5.9	43.2 / 17.0	60-75 / 27-34
130	1001	23.3	27.2 / 27.2	6.2	43.2 / 17.0	65-80 / 29-36
135	1083	23.7	27.6 / 27.6	6.5	45.7 / 18.0	70-85 / 32-39

OVERVIEW

Tech Features

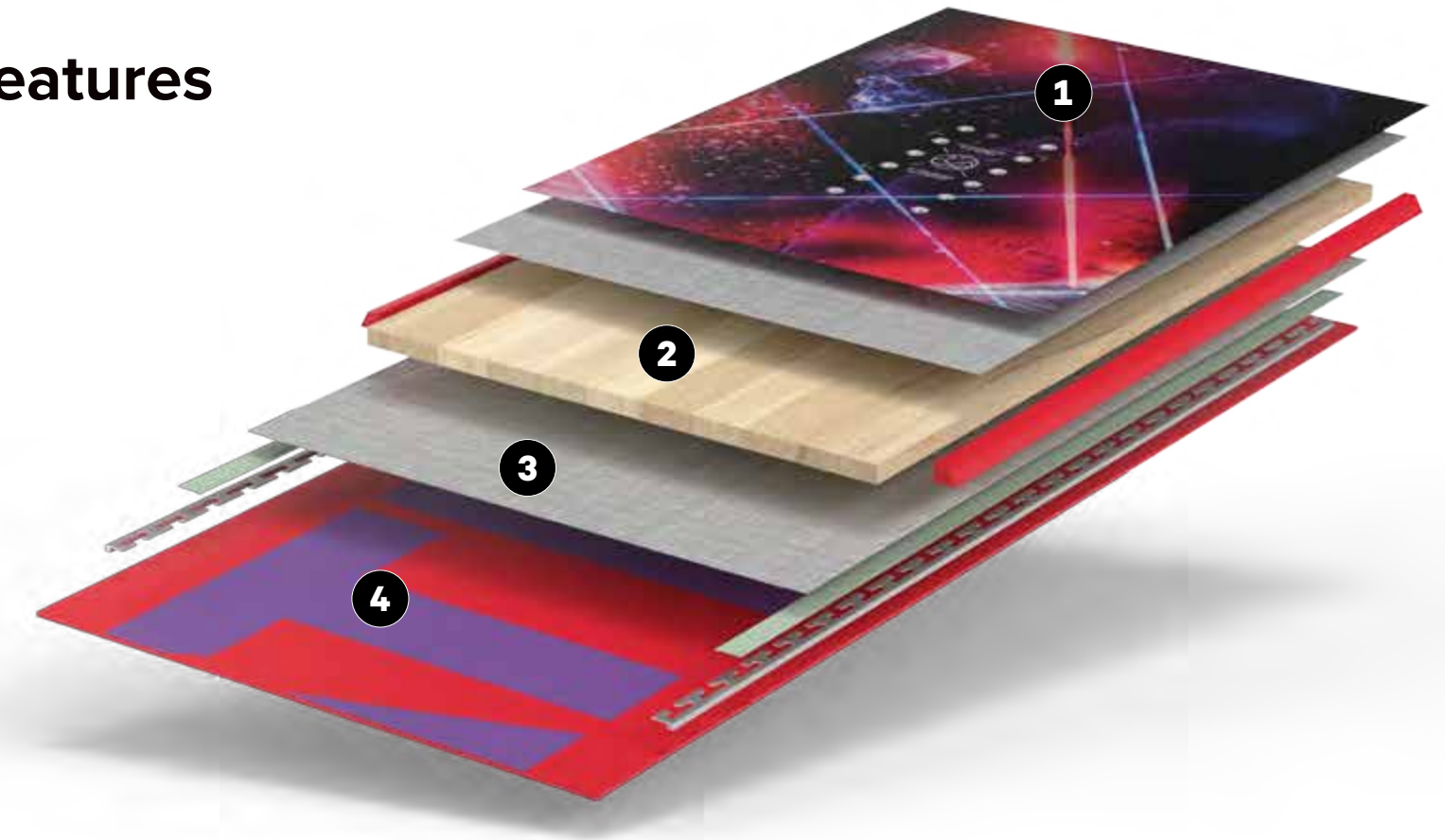

1 TOPSHEET TECH:
• Digital Print

2 CORE:
SELECT 2.0 CORE™

3 GLASS + RESIN:
MICRO-GLASS
MAGIC BEAN™ RESIN

4 BASE:
XXX[TRUDED]™
• Die-cut

CORE:
POPLAR

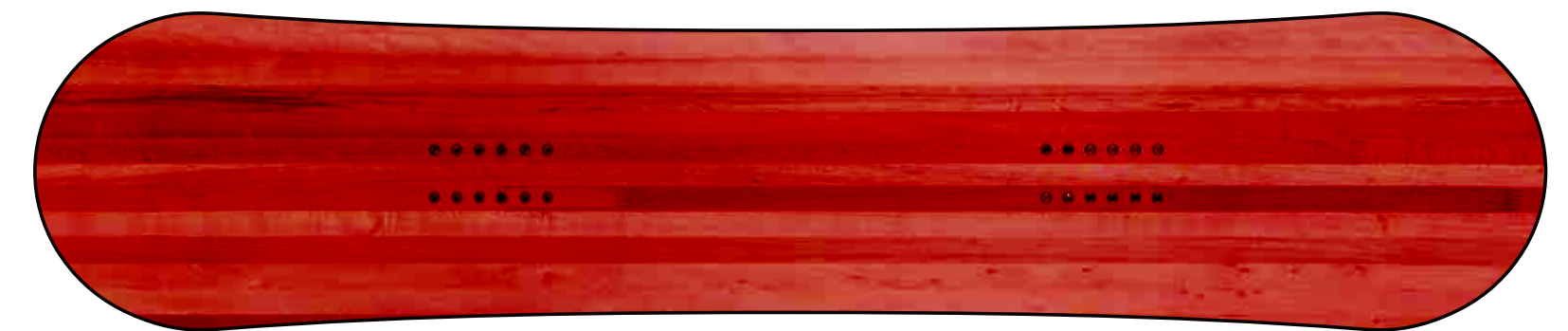

This construction utilizes a Select 2.0 Core™ in combination with a fast, yet easy to maintain XXX[TRUDED]™ base, providing a durable yet lightweight board to allow girls to play on fun stuff like park jumps, bumps, boxes, and freestyle terrain.

SCOTT STEVENS MINI

Youth / Resort + Park / True Twin / Reverse Camber

This mini-shred model is designed to bridge the gap between the Micro Mini and the smallest sizes of the mainline boards.

Produced at The MotherShip™, utilizing clean energy while featuring reforestation-certified sustainable woodcores, these boards are packed with technology at a price parents can afford. Combine that with fan-favorite graphics from *Scott Steven's* pro model archives and the inspiration from the legend himself, and you have an incredible youth board to fuel progression for groms.



SCOTT STEVENS MINI

Youth / Resort + Park / True Twin / Reverse Camber

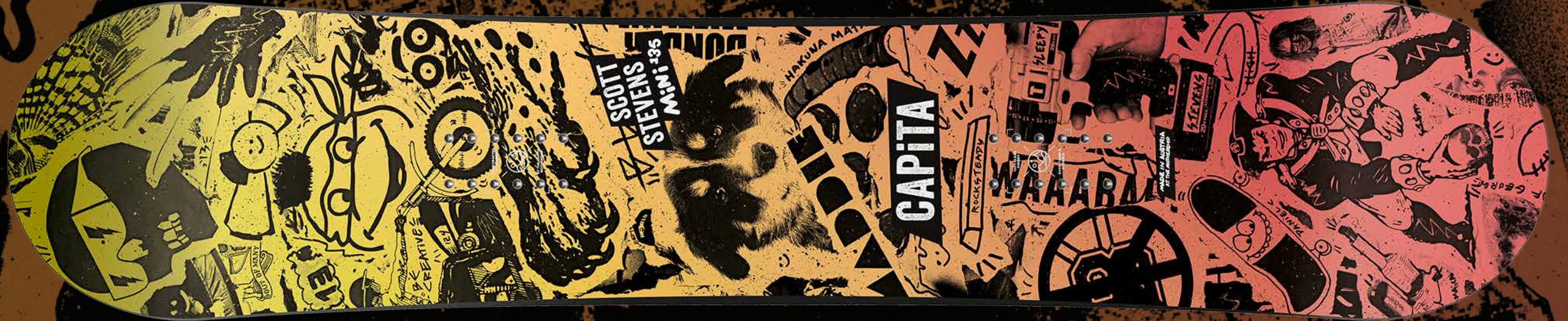

SCOTT STEVENS MINI

Youth / Resort + Park / True Twin / Reverse Camber

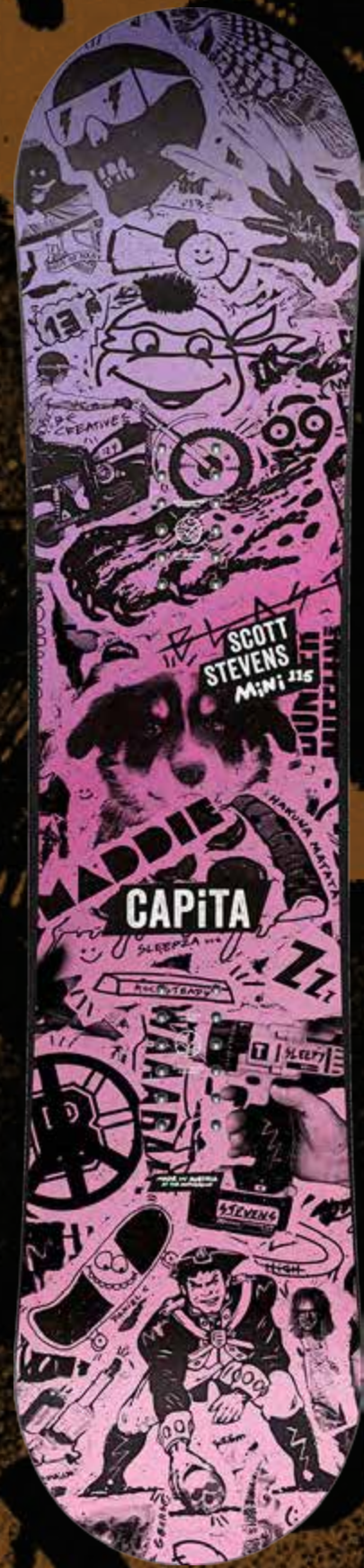

115



120



125



130



135



SCOTT STEVENS MINI



Catch-free riding for youth looking to progress during their early years of snowboarding.

RIDER TYPE:
Resort / Park

SHAPE:
True Twin

SIDECUT:
Radial

FLEX:
Twin 3

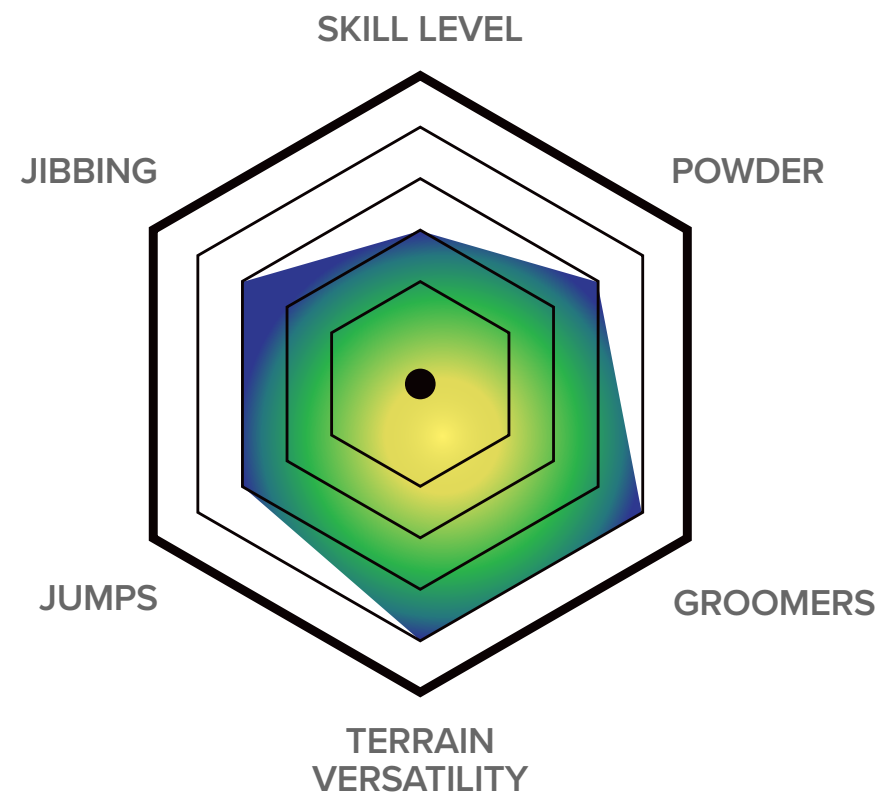

REVERSE CAMBER:
Park Mini

Rockered and beveled for catch free riding.



LENGTH	EFFECTIVE EDGE (mm)	WAIST	NOSE / TAIL	SIDECUT	REF. STANCE (cm / inches)	SUGGESTED WEIGHT (lbs / kg)
115	880	22.1	25.5 / 25.5	5.3	38.1 / 15.0	50-65 / 22-29
120	929	22.5	26.1 / 26.1	5.6	43.2 / 17.0	55-70 / 25-32
125	958	22.9	26.6 / 26.6	5.9	43.2 / 17.0	60-75 / 27-34
130	1001	23.3	27.2 / 27.2	6.2	43.2 / 17.0	65-80 / 29-36
135	1083	23.7	27.6 / 27.6	6.5	45.7 / 18.0	70-85 / 32-39

OVERVIEW

Tech Features

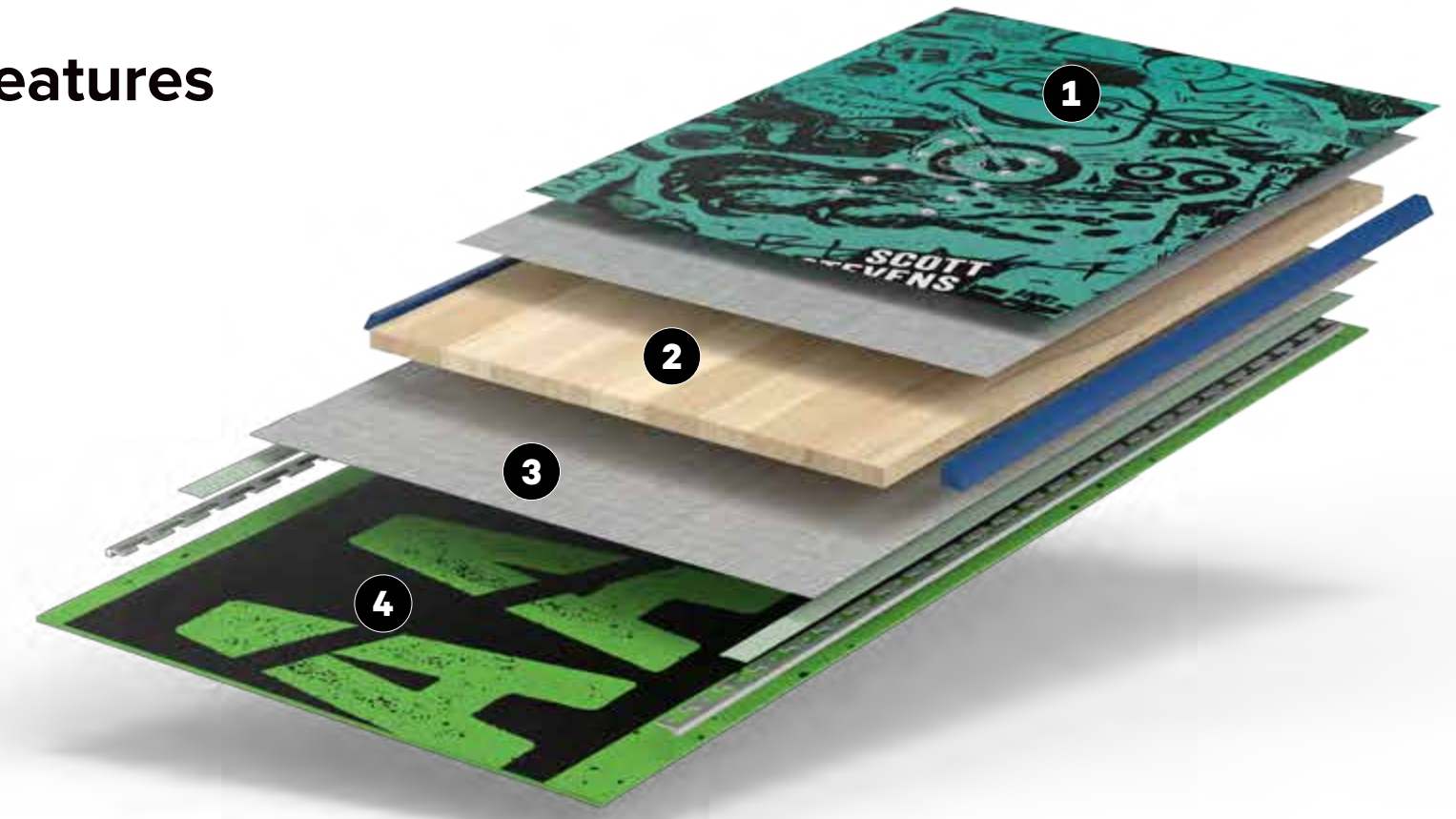

1
TOPSHEET TECH:
• Digital Print

2
CORE:
SELECT 2.0 CORE™

3
GLASS + RESIN:
MICRO-GLASS
MAGIC BEAN™ RESIN

4
BASE:
XXX[TRUDED]™
• Screen Print

CORE:
■ POPLAR

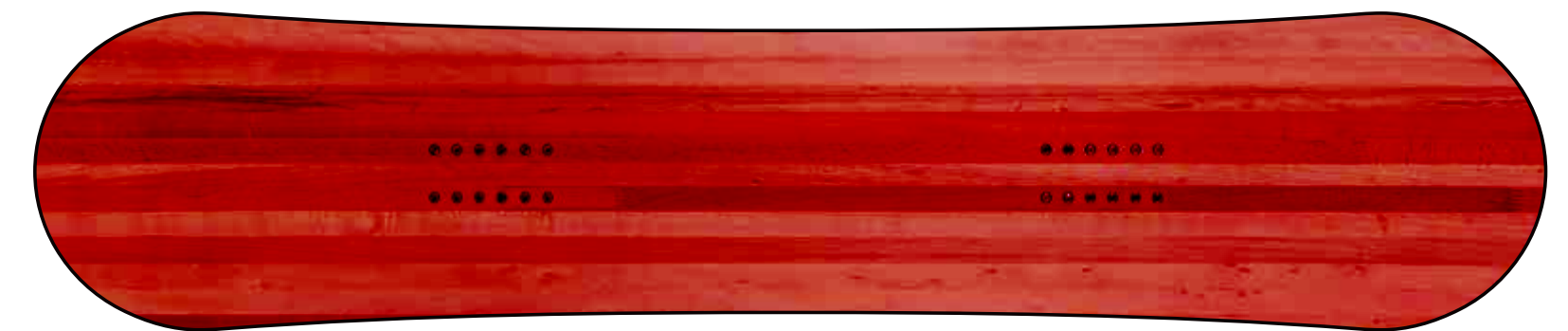

This construction utilizes a Select 2.0 Core™ in combination with a fast, yet easy to maintain XXX[TRUDED]™ base, providing a durable yet lightweight board to allow groms to play on fun stuff like park jumps, bumps, boxes, and freestyle terrain.

MICRO MINI

Youth / Resort + Park / True Twin / Reverse Camber

The *Micro Mini* is the perfect board for kids getting their first experiences in the snowboarding game.

Redesigned from the ground up, this new series features a new shape and sidecut to enhance the learning curve for young guns and new riders.

With a target age range from 2 years old on the 80, and upward of 8 years old on the 110, these are great learning boards when the length of the board reflects a range approximately between the distance from the floor to the rider's chin and brow.

With a custom engineered design to ensure ease of use, the *Micro Mini* is the ideal board for early turning and learning experiences.



MICRO MINI

Youth / Resort + Park / True Twin / Reverse Camber



MICRO MINI



Custom engineered and designed for mini-shredders learning to ride.

RIDER TYPE:
Resort / Park

SHAPE:
True Twin

SIDECUT:
Radial

FLEX:
Twin 3

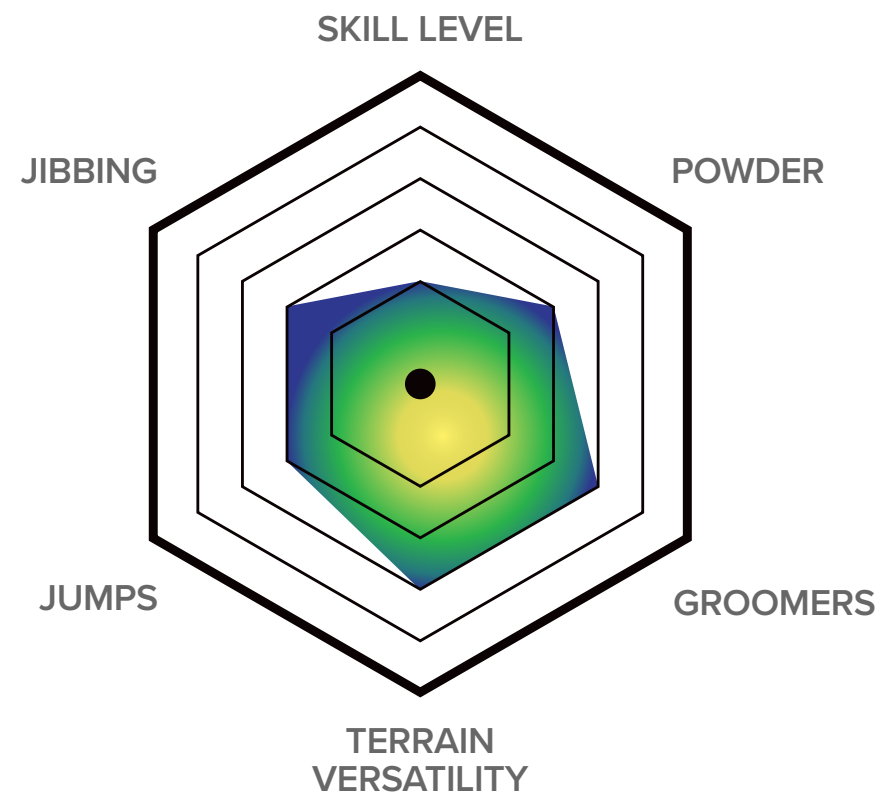

REVERSE CAMBER:
Park Mini
Rocker and beveled for catch free riding.



LENGTH	EFFECTIVE EDGE (mm)	WAIST	NOSE / TAIL	SIDECUT	REF. STANCE (cm / inches)	SUGGESTED WEIGHT (lbs / kg)
80	480	17.9	19.6 / 19.6	2.9	34.0 / 13.4	35-50 / 15-22
90	580	18.5	20.7 / 20.7	3.5	36.0 / 14.2	40-55 / 18-24
100	680	19.3	21.8 / 21.8	4.2	38.0 / 15.0	45-60 / 20-27
110	780	20.1	22.9 / 22.9	5.0	40.0 / 15.7	50-65 / 22-29

OVERVIEW

Tech Features



1
TOPSHEET TECH:
• EVA PAD
• Digital Print

2
CORE:
SELECT 2.0 CORE™

3
GLASS + RESIN:
MICRO-GLASS
MAGIC BEAN™ RESIN

4
BASE:
XXX[TRUDED]™
• Die-cut

CORE:
■ EVA PAD
■ POPLAR

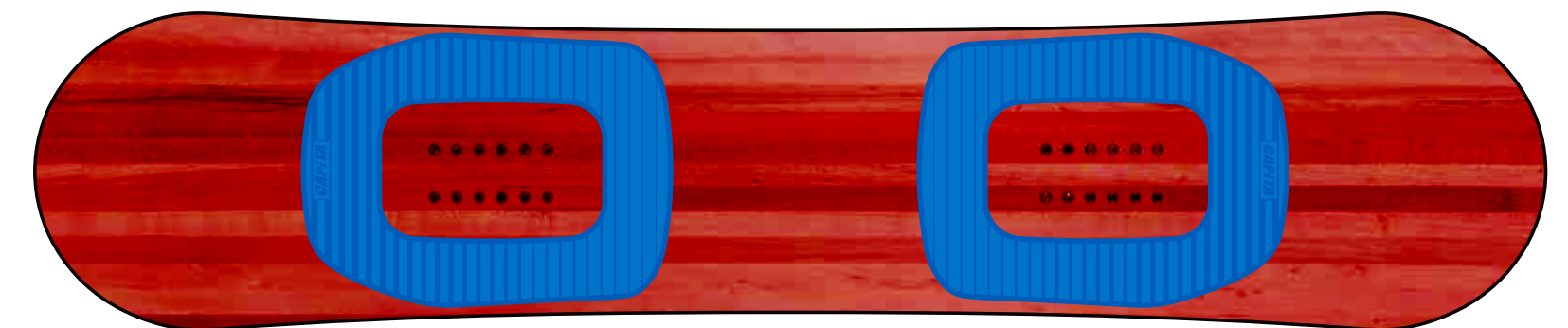

With a Select 2.0 Core™ and easy to maintain XXX[TRUDED]™ in combination with EVA Topsheet Pads, the Micro Mini provides a uniquely lightweight board with a flex ideal for early turning and learning experiences.

SPRING BREAK

U
R
N
G

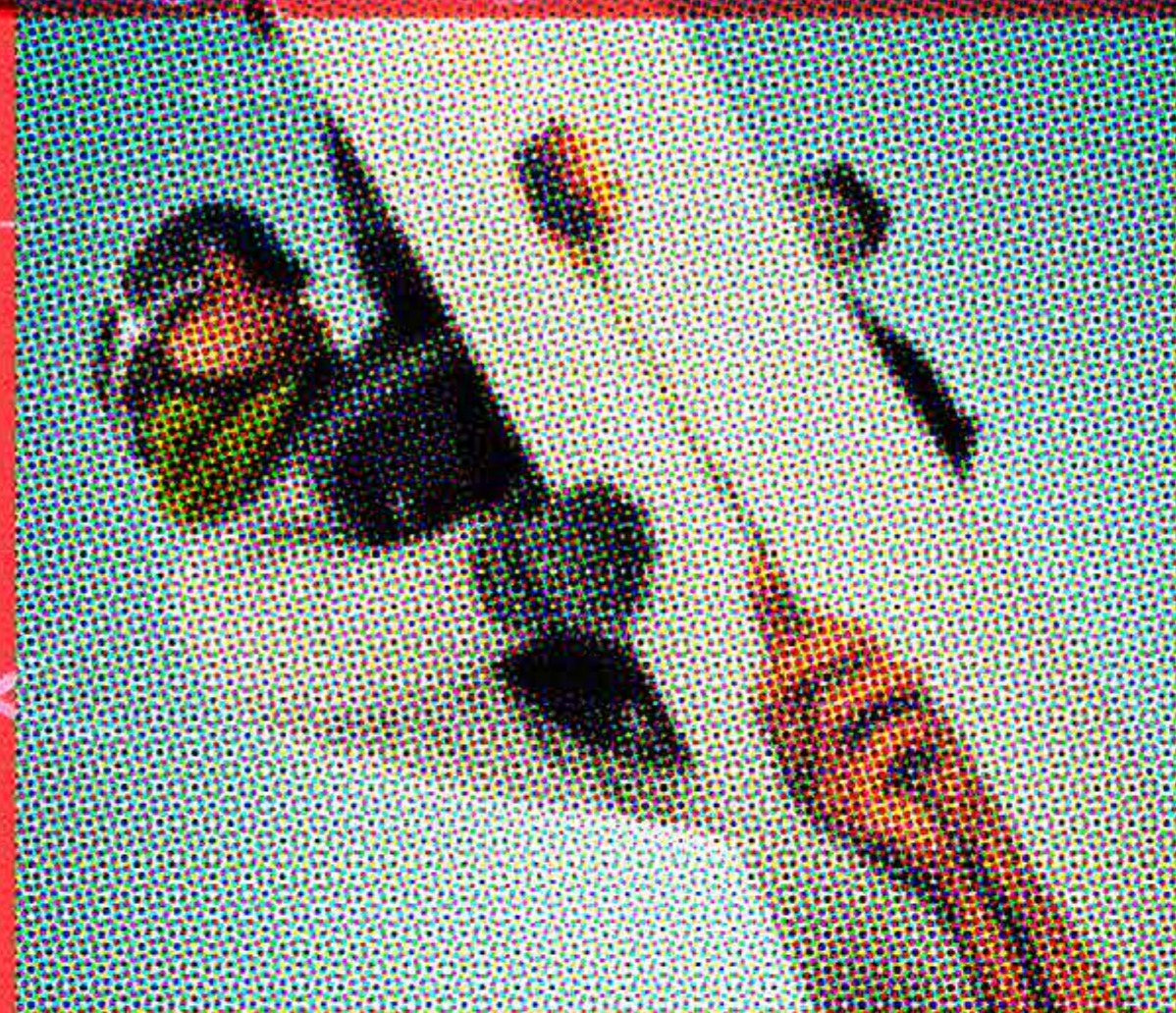

OLIVER DIXON

- COREY SMITH
- BLAISE ROSENTHAL
- ALEX "OZMAN" SCOTT
- JOEY FAVA
- ROBBIE SELL

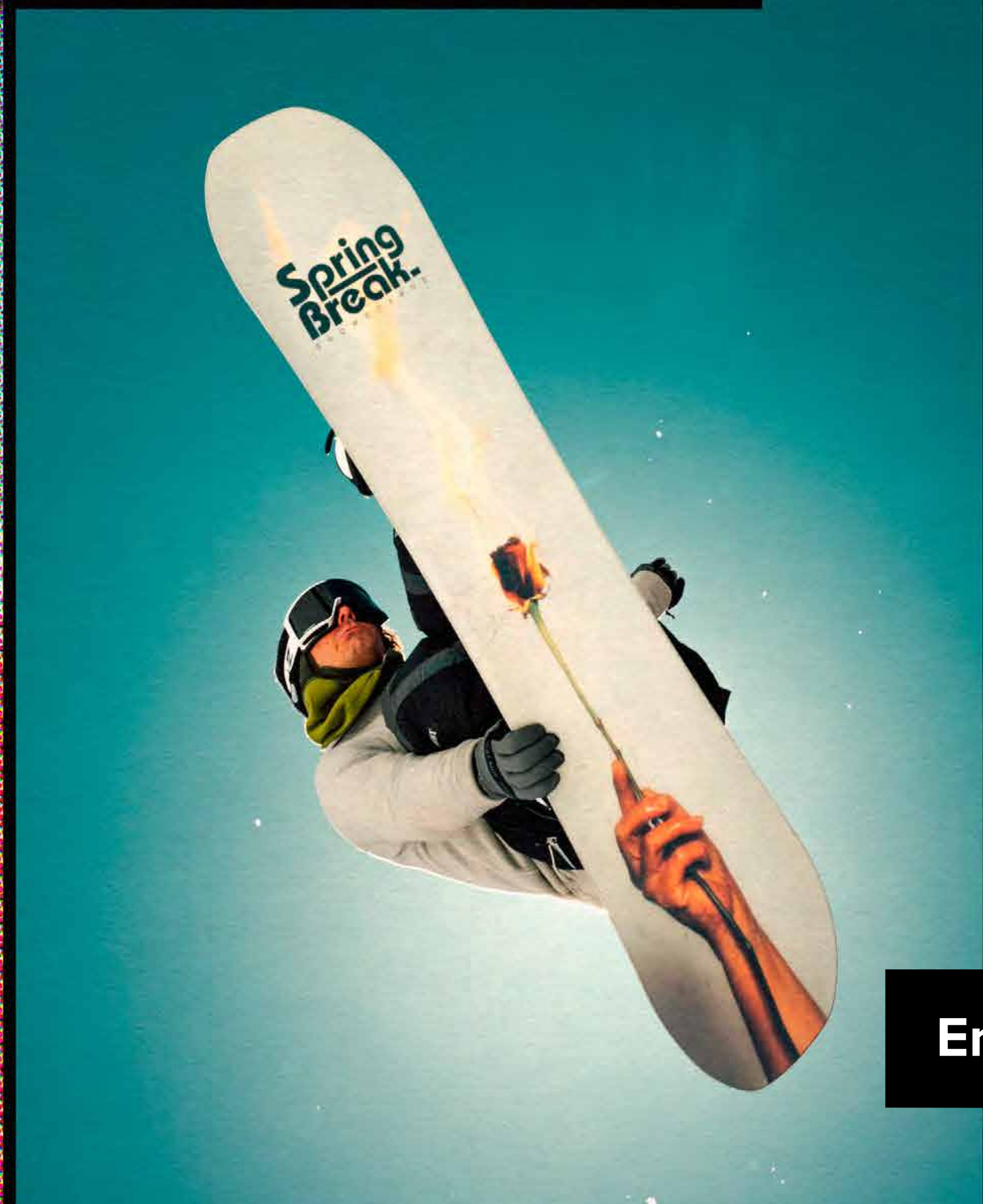

Engineered for Deep Paradise™.

AGE 2)

100

0-6 0-14 5-137

149... 5-27-76

SPRING BREAK



SB POWDER
GLIDER



SB POWDER
RACERS



SB POWDER
TWIN

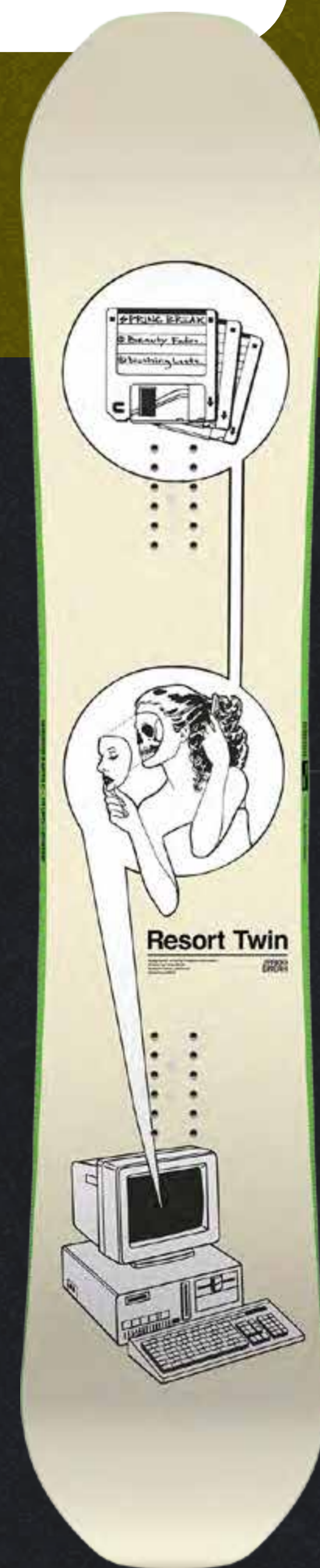

SB RESORT
TWIN

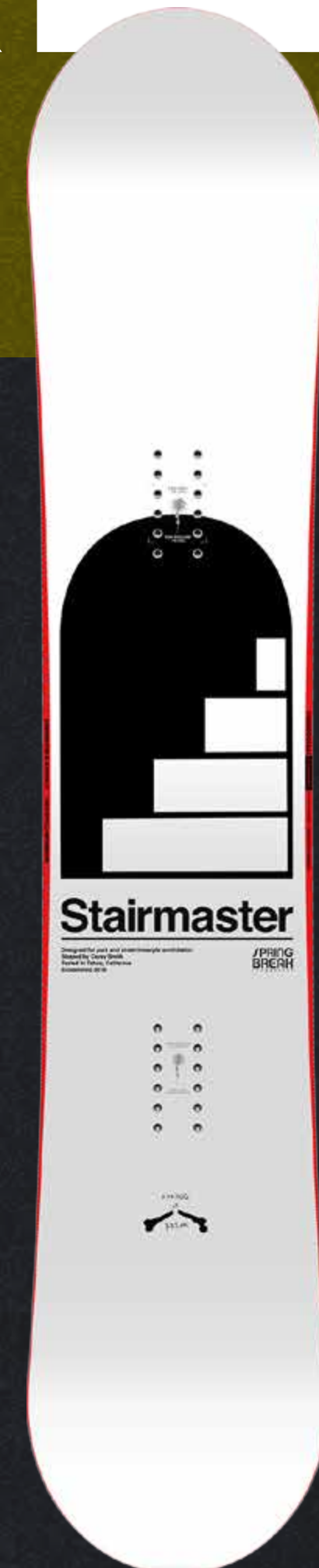

SB STAIRMASTER

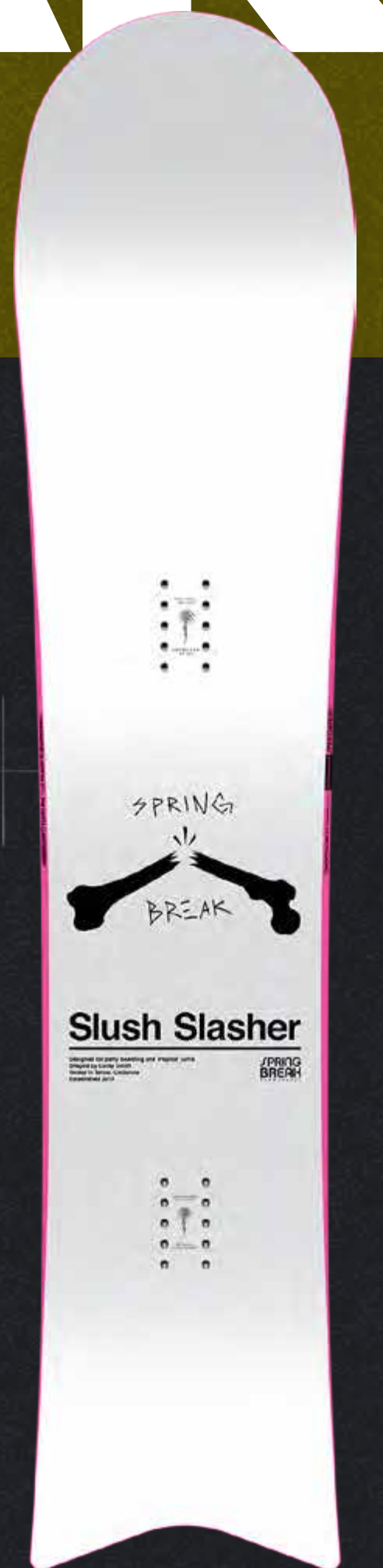

SB SLUSH
SLASHERS 2.0

SB POWDER GLIDERS

Powder Seeker / Directional / Reverse Camber

The *Spring Break Powder Gliders* align an advanced shaping theory from deep paradise and technical performance construction from The MotherShip™ into a backcountry game-changer.

With a wide-framed nose, directional shape, and tons of taper, these boards will float through the deepest pow and deliver in your search for endless tropical turns.

SB POWDER GLIDER

Spring Break / Powder Seeker / Directional / Reverse Camber

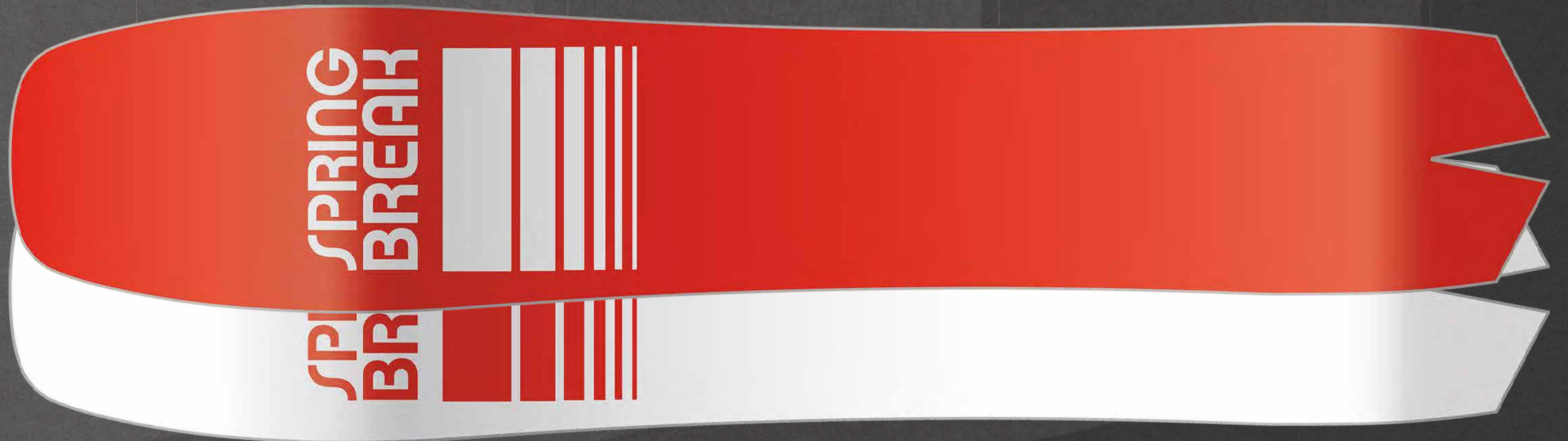

SPRING BREAK POWDER GLIDER



The ultimate snowcraft for tropical turns in Deep Paradise™.

RIDER TYPE:
Powder Seeker

SHAPE:
**Directional
0.8" Set Back**

SIDECUT:
**Surf Blended
Radial**

FLEX:
**Directional
6**

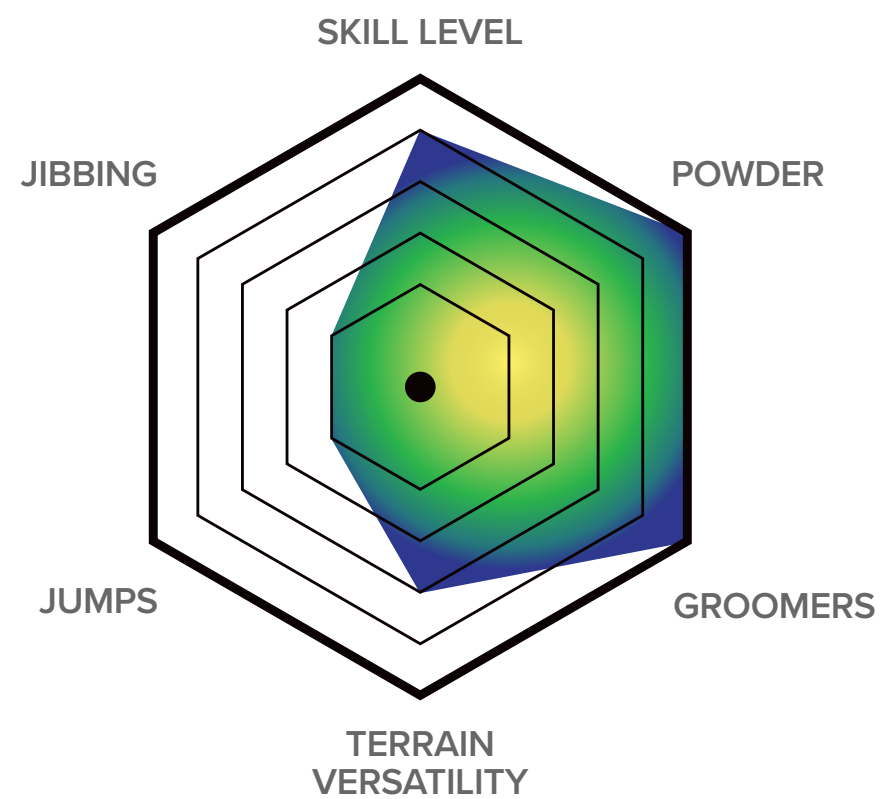

REVERSE CAMBER:
Surf Rocker

The *SURF ROCKER* features a continuous arching tip and tail inspired by the modern design of many of today's best surfboards: flat through the inserts with smooth arching tip and tails. The gentle low angle allows for maximum float and control.

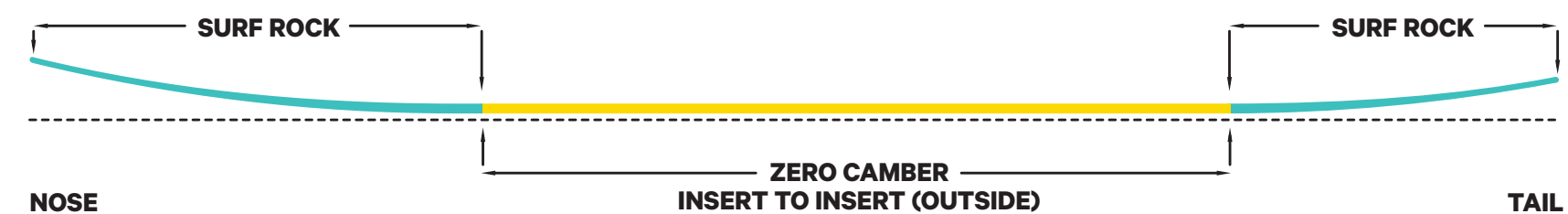

LENGTH	EFFECTIVE EDGE (mm)	WAIST	NOSE / TAIL	TAPER	SIDECUT	REF. STANCE (cm / inches)	SUGGESTED WEIGHT (lbs / kg)
154	925	26.2	30.7 / 27.1	35.7	6.7	53.3 / 21.0	120-180 / 54-81
158	949	26.9	31.5 / 27.8	36.7	6.9	55.9 / 22.0	140-200 / 63-90
162	973	27.6	32.3 / 28.5	37.6	7.0	58.4 / 23.0	160-220 / 72-99

OVERVIEW

Tech Features

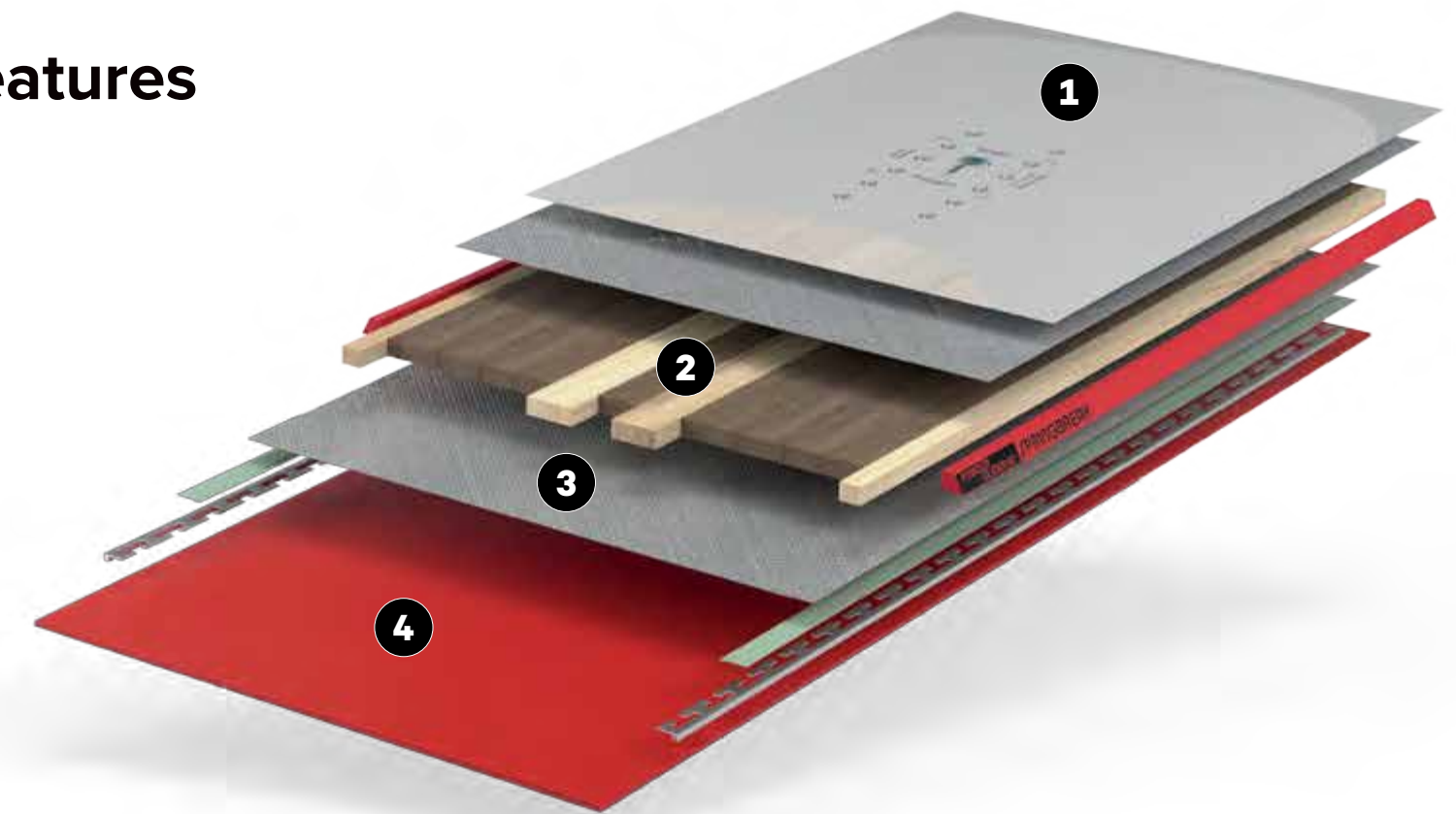

1
TOPSHEET TECH:
PLT Technology
• Digital + Screen Print

2
CORE:
SURFLITE 4.0 CORE™

3
GLASS + RESIN:
**HOLYSHEET™ TRI/TRI
MAGIC BEAN™ RESIN**

4
BASE:
POWDER DRIVE™
• Screen Print + Die-cut

CORE:
■ CARBON FLEECE
■ PAULOWNIA
■ MEGA-PREMIUM POPLAR



The *Powder Glider* is built with a premium Surflite 4.0 Core™ and Carbon Fleece Power Shields™ for ultralight weight toughness. Combined with a wide-framed nose and directional shape with tons of taper, the ultimate floatation performance is achieved.

SB POWDER RACERS

Powder + Resort / Directional / Hybrid Camber

The *Spring Break Powder Racers* utilize one of the best-selling shapes from the sought-after Spring Break Ultralight Archives with a more accessibly priced construction.

Utilizing a large surface area to increase floatation and deep sidecuts to carve up the slopes, the *Powder Racers* produce party vibes in powder and on groomers alike.

SB POWDER RACERS

Spring Break / Powder + Resort / Directional / Hybrid Camber



SPRING BREAK POWDER RACERS



The ultimate snowcraft for tropical turns on a budget.

RIDER TYPE:
Powder / Resort

SHAPE:
**Directional
0.5" Set Back**

SIDECUT:
**Surf Blended
Radial**

FLEX:
**Directional
5**

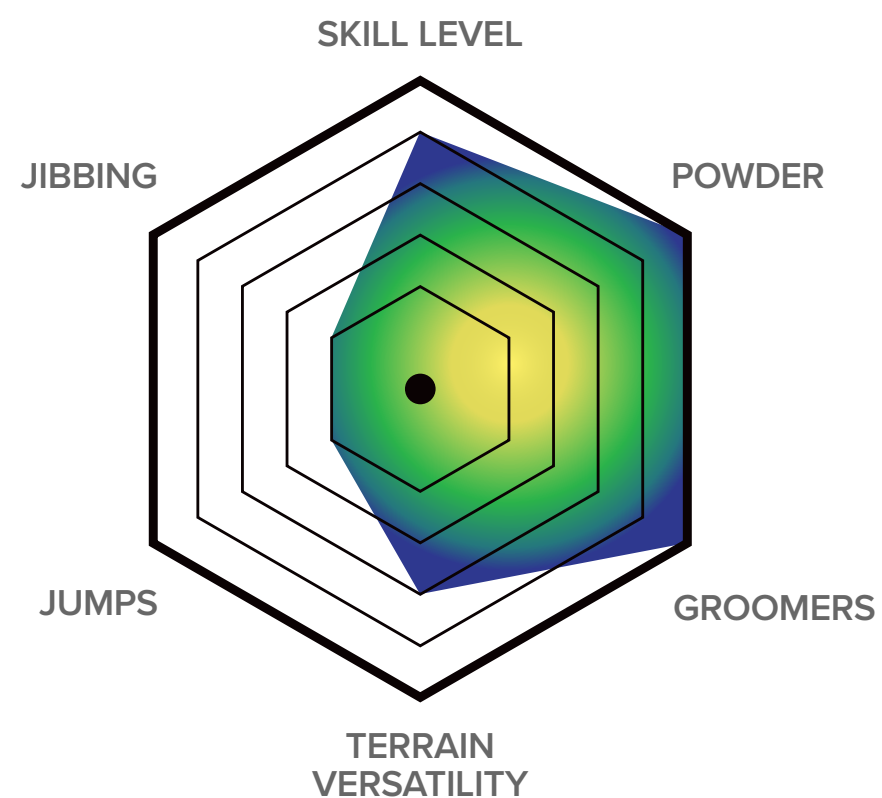

HYBRID CAMBER:
Surf Camber

The *SURF CAMBER* features smooth arcing tip and tails and camber through the inserts. The gentle low angle allows for maximum float and control.

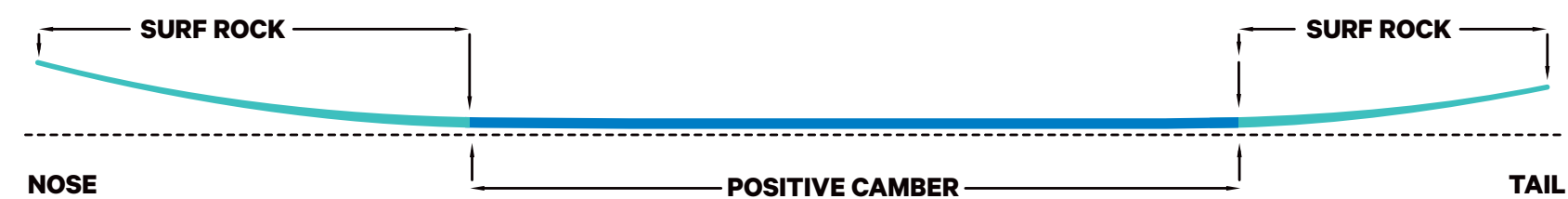

LENGTH	EFFECTIVE EDGE (mm)	WAIST	NOSE / TAIL	TAPER	SIDECUT	REF. STANCE (cm / inches)	SUGGESTED WEIGHT (lbs / kg)
149	1038	26.3	31.6 / 28.4	31.3	6.5	50.8 / 20.0	110-160 / 49-72
151	1052	26.7	32.0 / 28.8	31.7	6.6	53.3 / 21.0	120-170 / 54-77
154	1073	27.2	32.6 / 29.4	31.7	6.8	53.3 / 21.0	130-180 / 59-81
157	1094	27.8	33.3 / 30.0	33.0	6.9	55.9 / 22.0	140-200 / 63-90

OVERVIEW

Tech Features

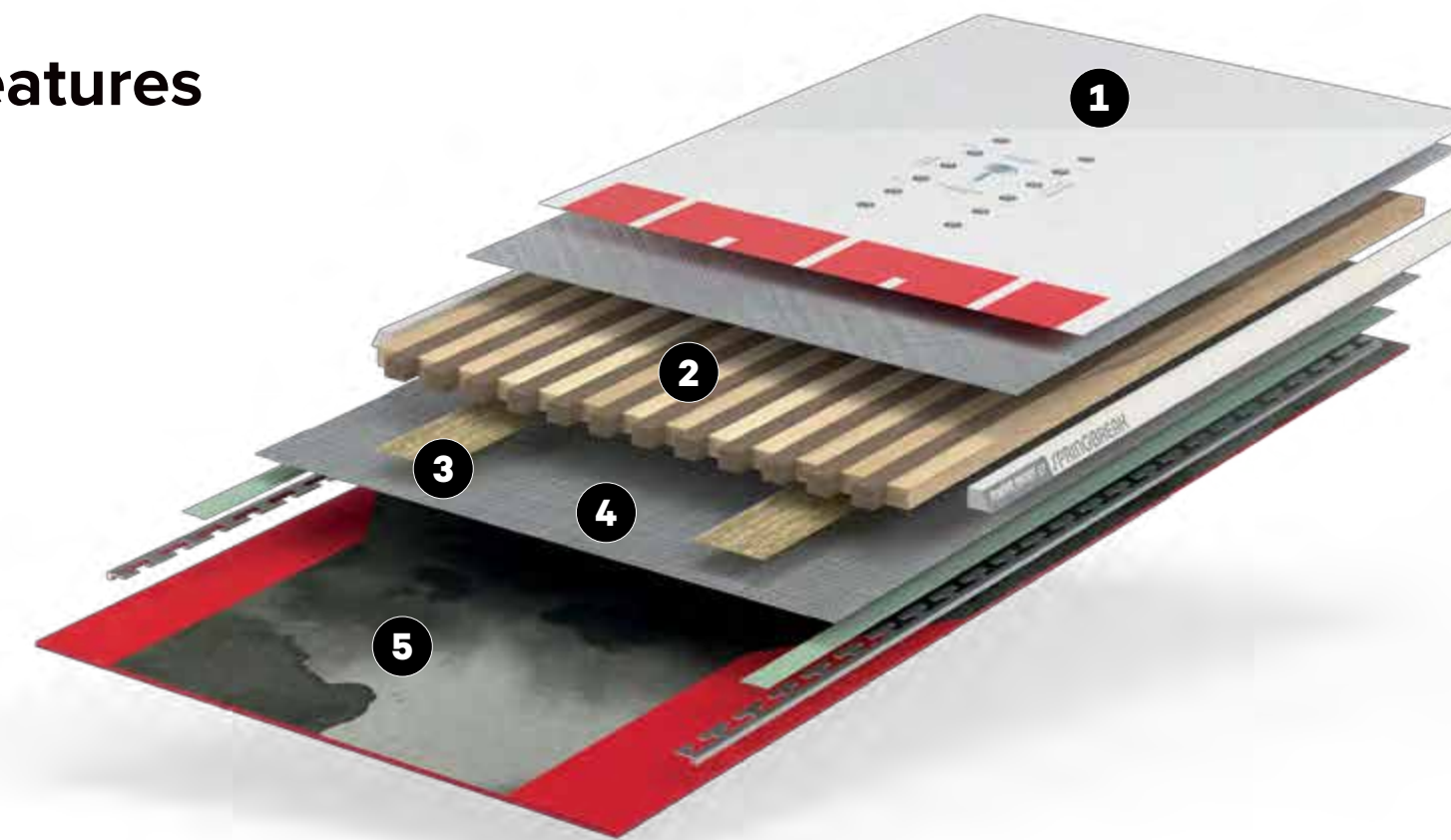

1
TOPSHEET TECH:
PLT Technology
• Digital + Screen Print

2
CORE:
HOVER CORE™

3
ADDITIVES:
2 x 30 mm
TECHNORA™ FLAX
BOOSTERS

4
GLASS + RESIN:
HOLYSHEET™ TRI/BI
MAGIC BEAN™ RESIN

5
BASE:
POWDER DRIVE™
• Sublimation + Die-cut

CORE:
■ TECHNORA™ FLAX
■ PAULOWNIA
■ POPLAR



The *Powder Racers* achieves its easier-on-the-wallet, lightweight construction with a Hover Core™ and Technora™ Flax Boosters, while unlocking super floatation performance with a wide-framed nose in a directional shape with tons of taper.

SB POWDER TWIN

Powder + Resort / True Twin / Hybrid Camber

This ain't no business-in-the-front and party-in-the-back type product. It's all business and all party, and it's like that all the time.

With a rarely seen symmetrical approach to party boarding, we present you with the *Spring Break Powder Twin*. Yep, it looks like a twin-tip park board but guess what? It retains many of the geometric theories that have made Spring Break Snowboards legendary in powder—and on the corduroy.

SB POWDER TWIN

Spring Break / Powder + Resort / True Twin / Hybrid Camber



149

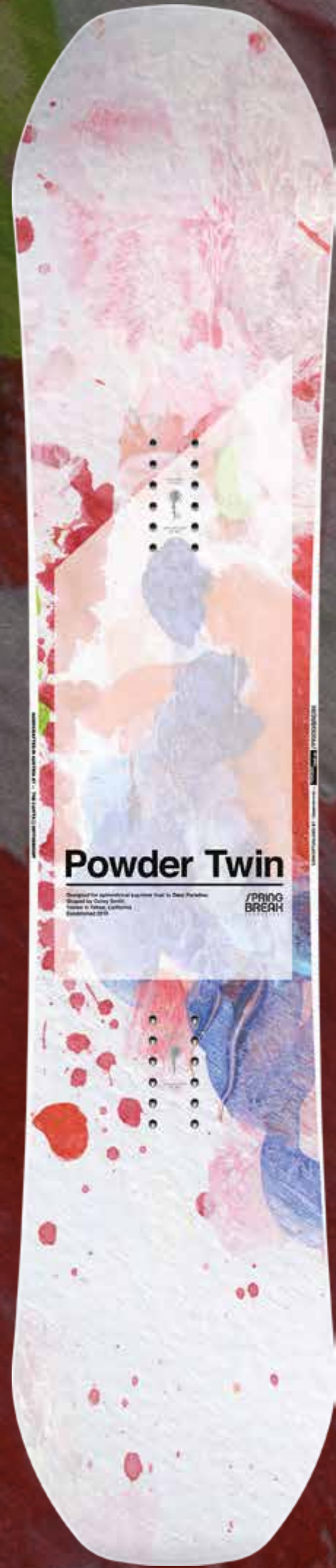

151



154



157



BASE

SPRING BREAK POWDER TWIN



A Spring Break extra wide, twin-tip series for stomping powder landings in either direction.

RIDER TYPE:
Powder / Resort

SHAPE:
True Twin

SIDECUT:
Blended Radial

FLEX:
**True Twin
5**

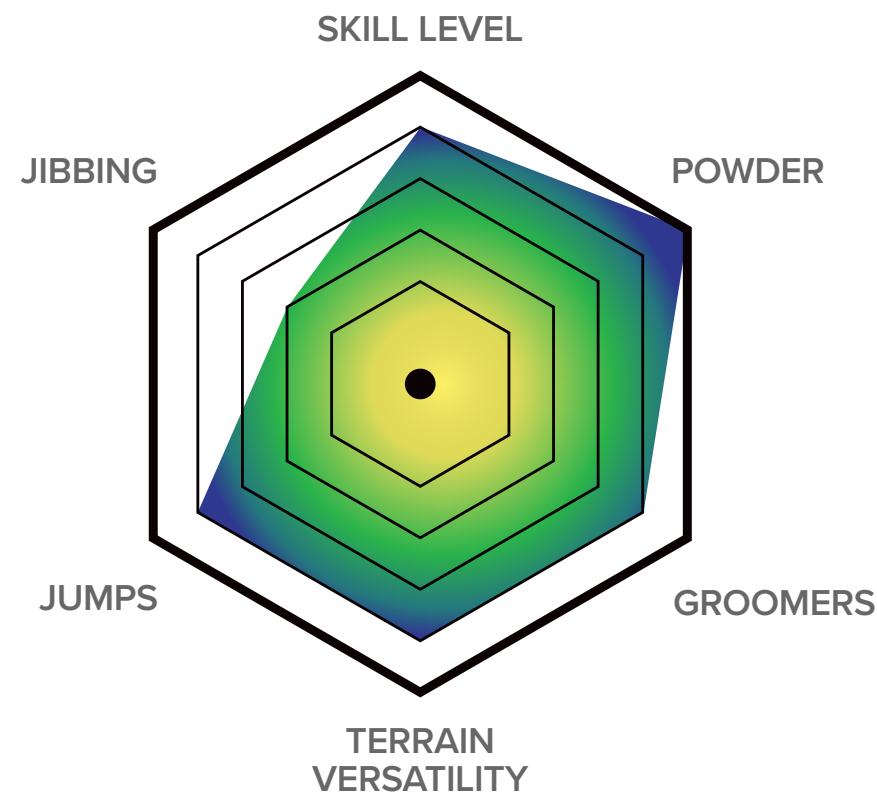

HYBRID CAMBER:
Surf Camber Twin

The *SURF CAMBER TWIN* features smooth arcing tip and tails with a small zero camber section and camber through the inserts. The gentle low angle allows for maximum float and control.

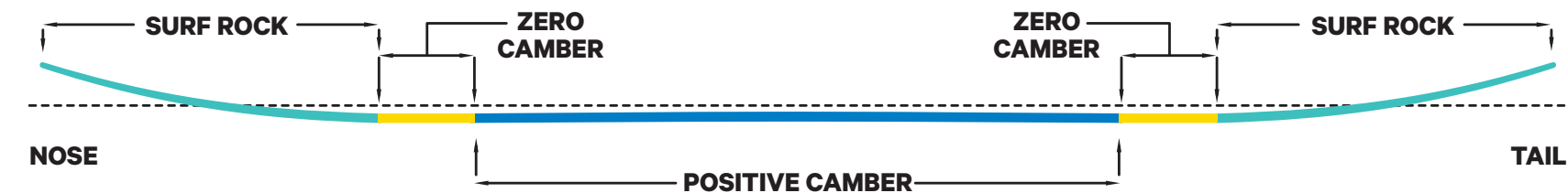

LENGTH	EFFECTIVE EDGE (mm)	WAIST	NOSE / TAIL	SIDECUT	REF. STANCE (cm / inches)	SUGGESTED WEIGHT (lbs / kg)
153	1116	26.3	30.9 / 30.9	6.5	53.3 / 21.0	110-170 / 50-77
156	1138	26.8	31.5 / 31.5	6.6	55.9 / 22.0	120-180 / 54-82
159	1160	27.3	32.1 / 32.1	6.7	55.9 / 22.0	140-200 / 63-90
162	1182	27.8	32.7 / 32.7	6.8	58.4 / 23.0	160-220 / 77-100

OVERVIEW

Tech Features

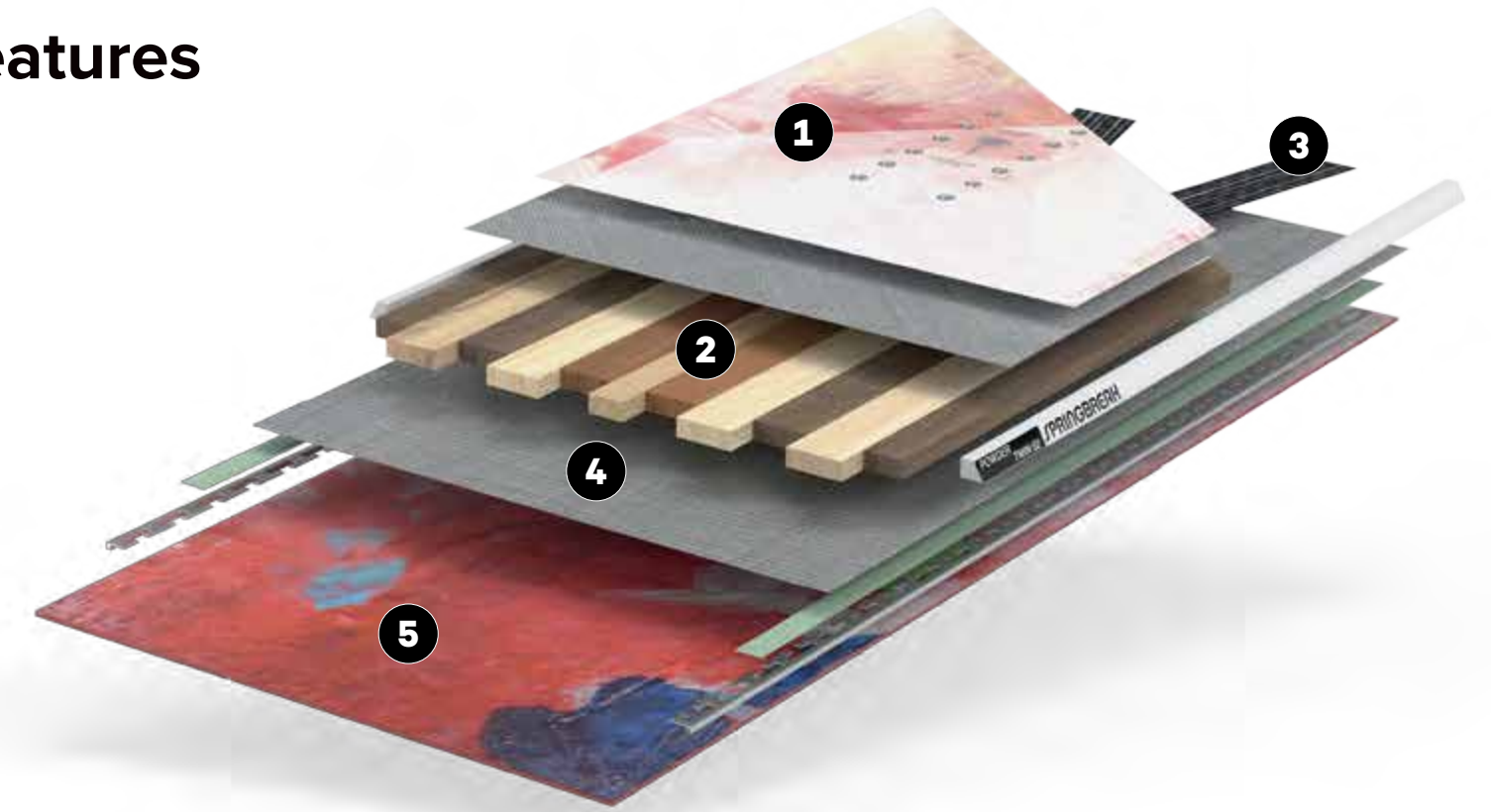

1 TOPSHEET TECH:
PLT Technology
• Digital + Screen
+ Gloss/Matte Print
• Metallic Underlay

2 CORE:
META CORE™

3 ADDITIVES:
4 x 30 mm
**CARBON V-TECH
AMPLIFIERS**

4 GLASS + RESIN:
**HOLYSHEET™ TRI/BI
MAGIC BEAN™ RESIN**

5 BASE:
POWDER DRIVE™
• Digital Print

CORE:

- CARBON
- BEECH
- PAULOWNIA
- POPLAR



With a super-wide chassis, and a Surf Camber profile for maximum floatation, the *Spring Break Powder Twin* comes in an advanced construction with a Meta Core™, Carbon V-Tech Amplifiers and a HolySheet™ Tri/Bi Fiberglass configuration to ensure the pop and power needed to stomp powder landings.

SB RESORT TWIN

Park + Resort / True Twin / Hybrid Camber

The *Spring Break Resort Twin* aligns the unique vibe of Spring Break tropical snowboarding with a proper twin freestyle shape aimed at the masses.

With waist-widths more in-line with conventional freestyle and resort snowboards and an iconic twin silhouette respectful of its big brother, the *SB Powder Twin*, these are your everyday resort shreds for fans of Spring Break.

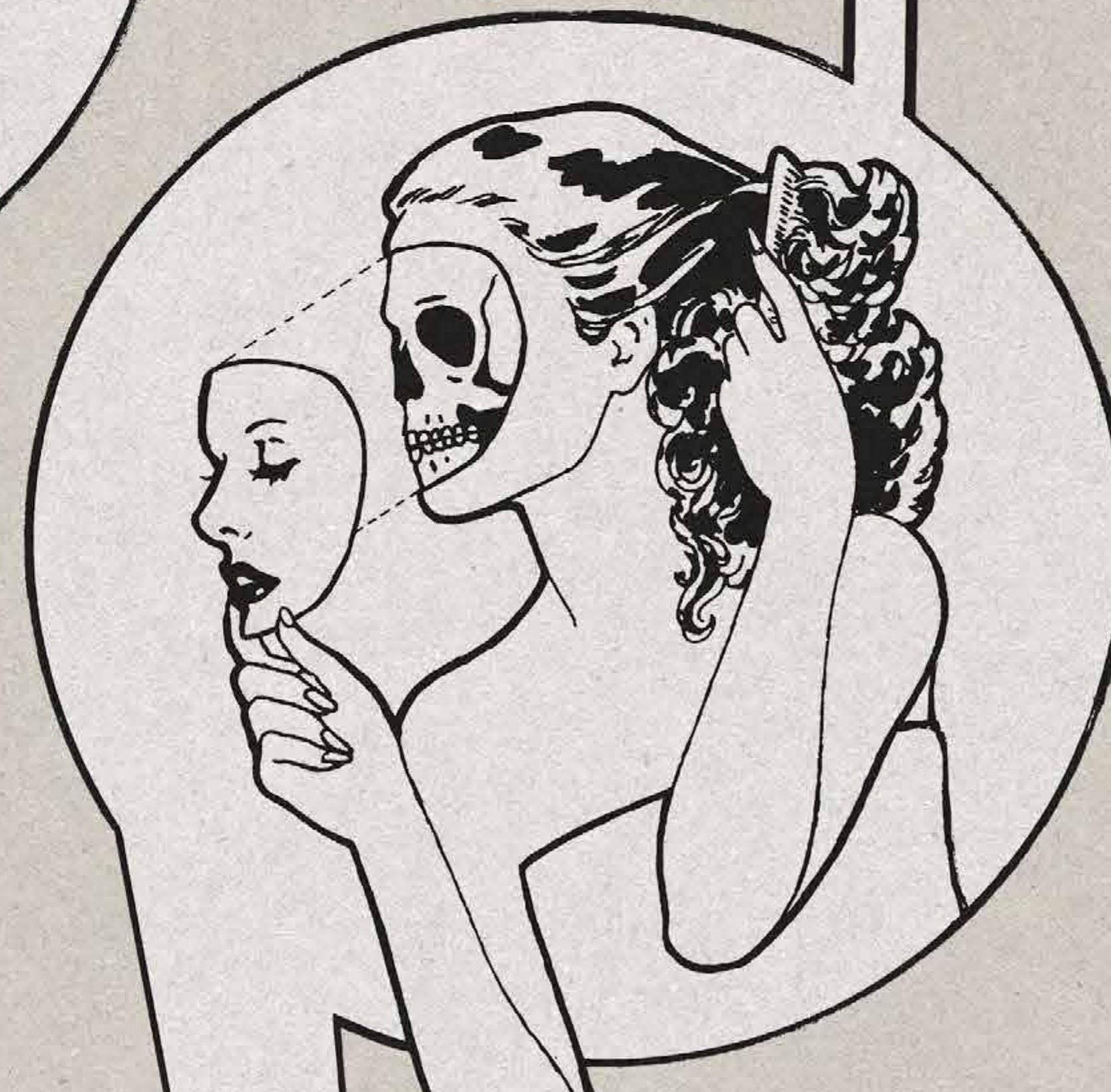

SB RESORT TWIN

Spring Break / Park + Resort / True Twin / Hybrid Camber

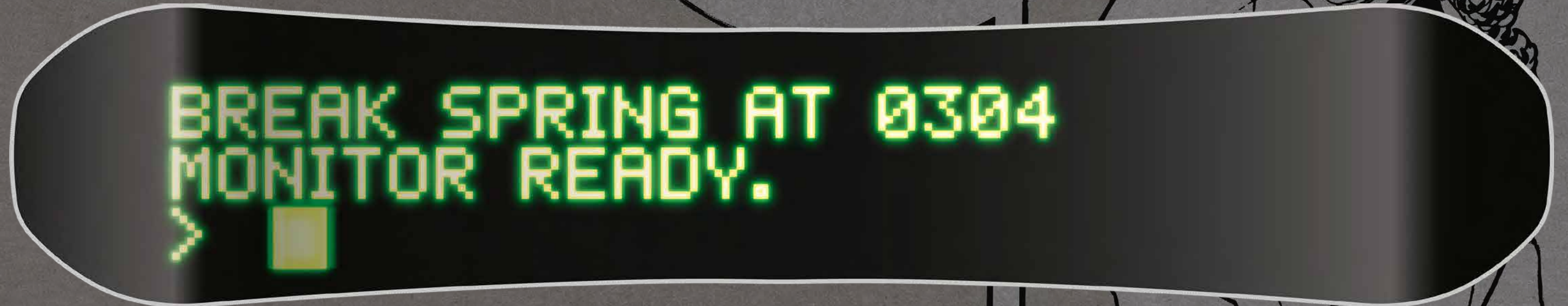
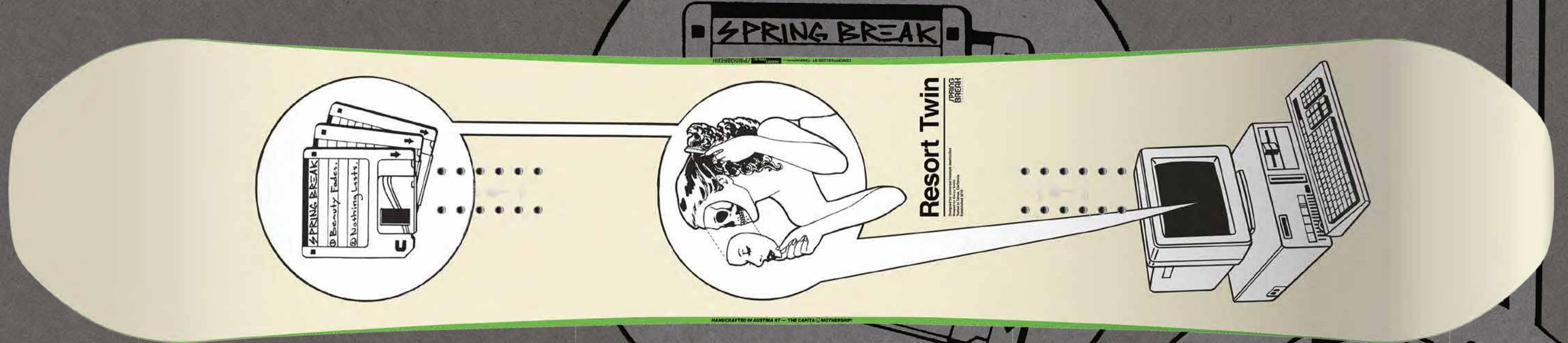

SB RESORT TWIN WIDE

Spring Break / Park + Resort / True Twin / Hybrid Camber

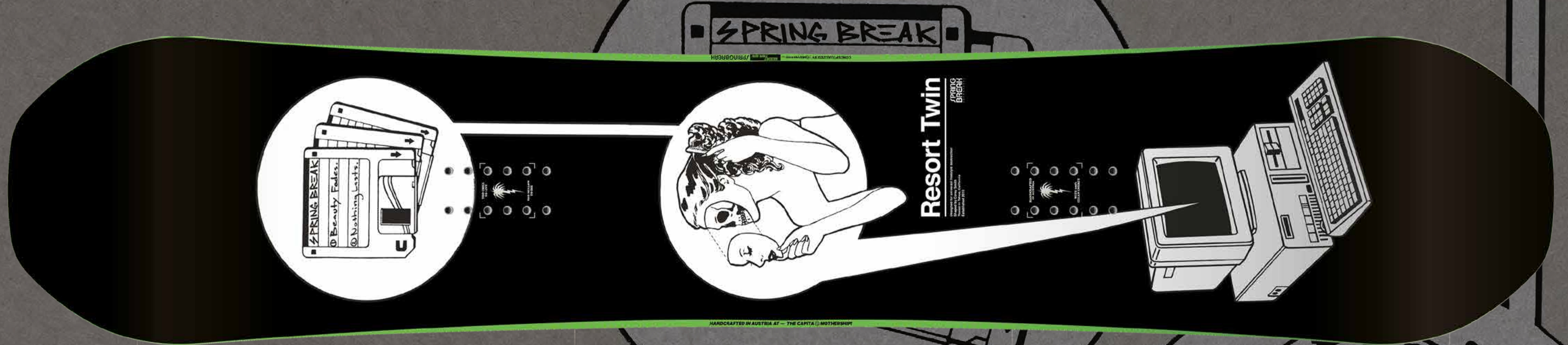

BREAK SPRING AT 0304
MONITOR READY.
> █

SPRING BREAK RESORT TWIN

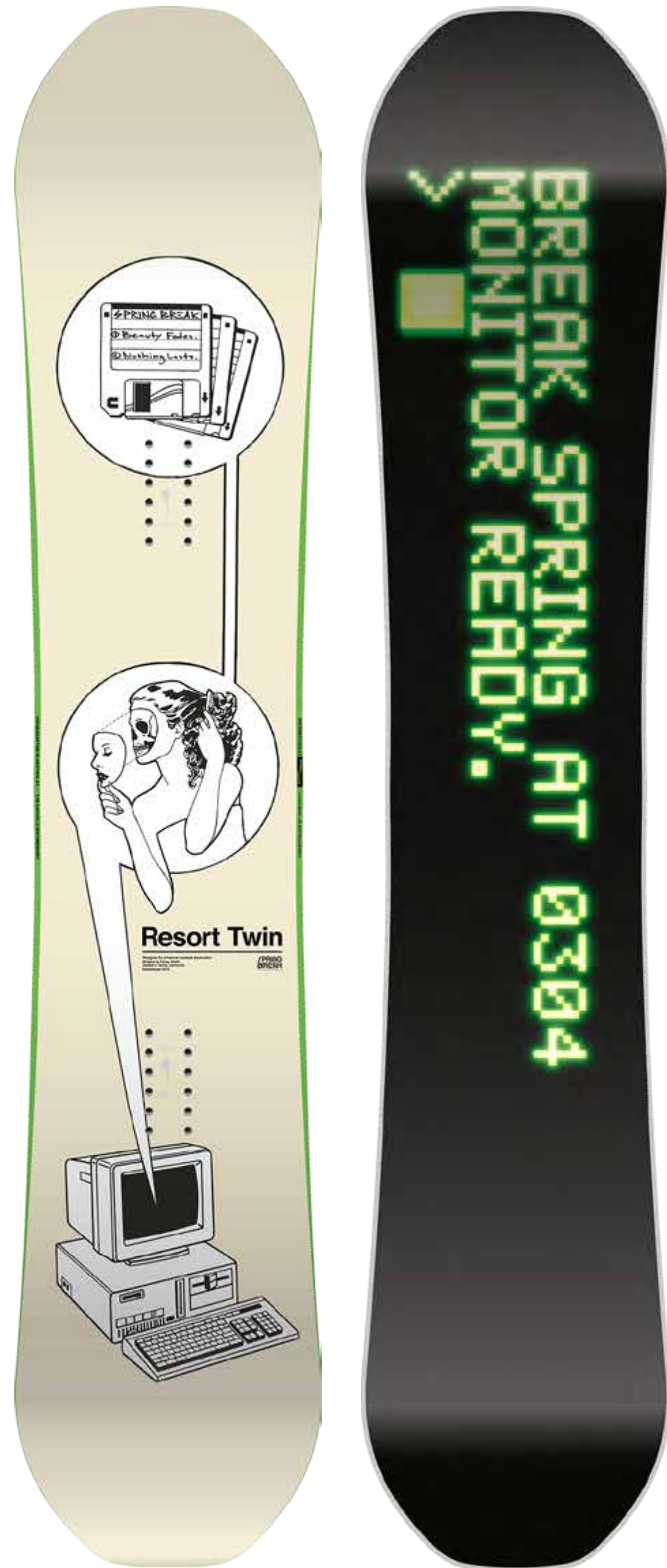

For the Spring Break fan seeking to ride a resort board in traditional widths.

RIDER TYPE:
Park / Resort

SHAPE:
True Twin

SIDECUT:
**New Age Radial
Death Grip™**

FLEX:
**Twin
5**

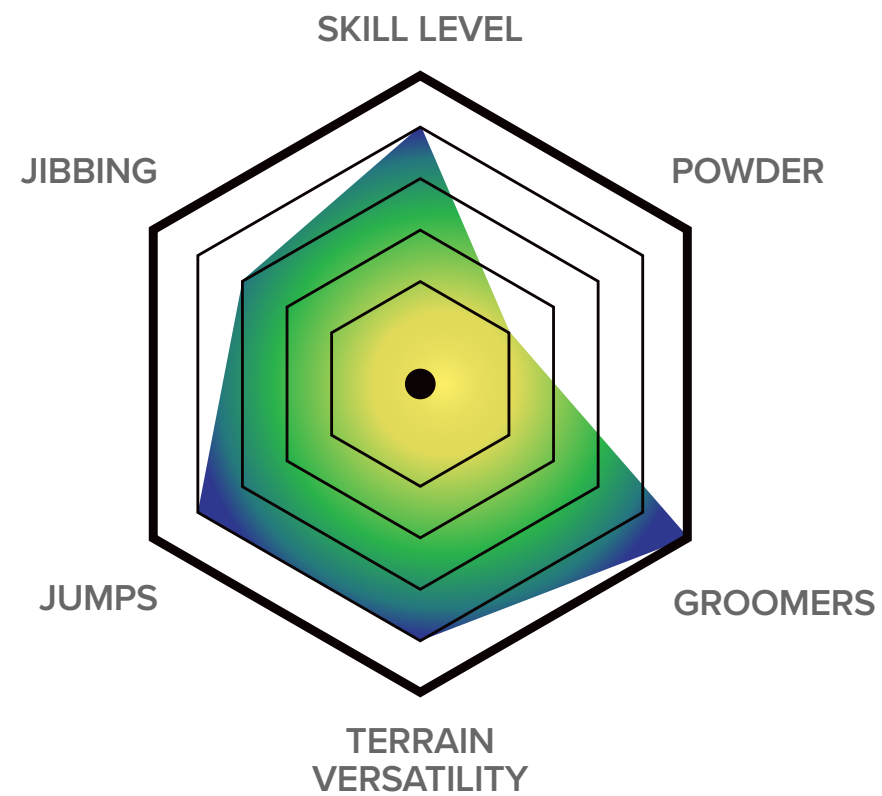

HYBRID CAMBER:
Resort V2 Directional + Flat Kick Tech

This revolutionary all-terrain shape provides the best of both worlds. It has a raised camber platform through the inserts to retain high-speed edge hold through variable terrain, elevated contact points to land and float in powder, and Flat Kick tip and tail arcs for faster, more aggressive transitions.

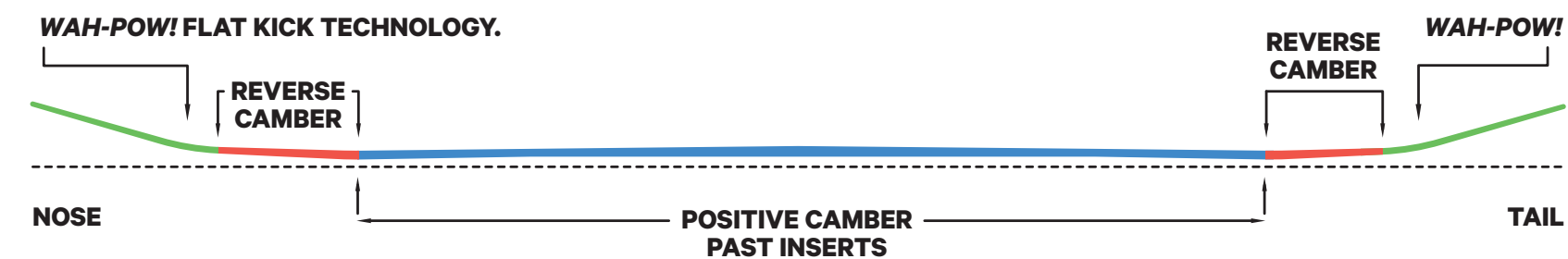

LENGTH	EFFECTIVE EDGE (mm)	WAIST	NOSE / TAIL	SIDECUT	REF. STANCE (cm / inches)	SUGGESTED WEIGHT (lbs / kg)
152	1180	25.0	29.6 / 29.6	7.7 / -1.5 / 7.7	53.3 / 21.0	110-160 / 50-72
154	1196	25.5	30.0 / 30.0	7.9 / -1.5 / 7.9	53.3 / 21.0	120-180 / 54-81
156	1211	25.8	30.4 / 30.4	7.9 / -1.5 / 7.9	55.9 / 22.0	130-190 / 59-86
158	1227	26.0	30.8 / 30.8	8.0 / -1.5 / 8.0	55.9 / 22.0	140-200 / 63-90
160	1242	26.2	31.2 / 31.2	8.1 / -1.5 / 8.1	58.4 / 23.0	150-210 / 68-95
155 W	1203	26.1	30.9 / 30.9	7.9 / -1.5 / 7.9	55.9 / 22.0	130-190 / 59-86
158 W	1227	26.5	31.3 / 31.3	8.0 / -1.5 / 8.0	55.9 / 22.0	140-200 / 63-90

OVERVIEW

Tech Features

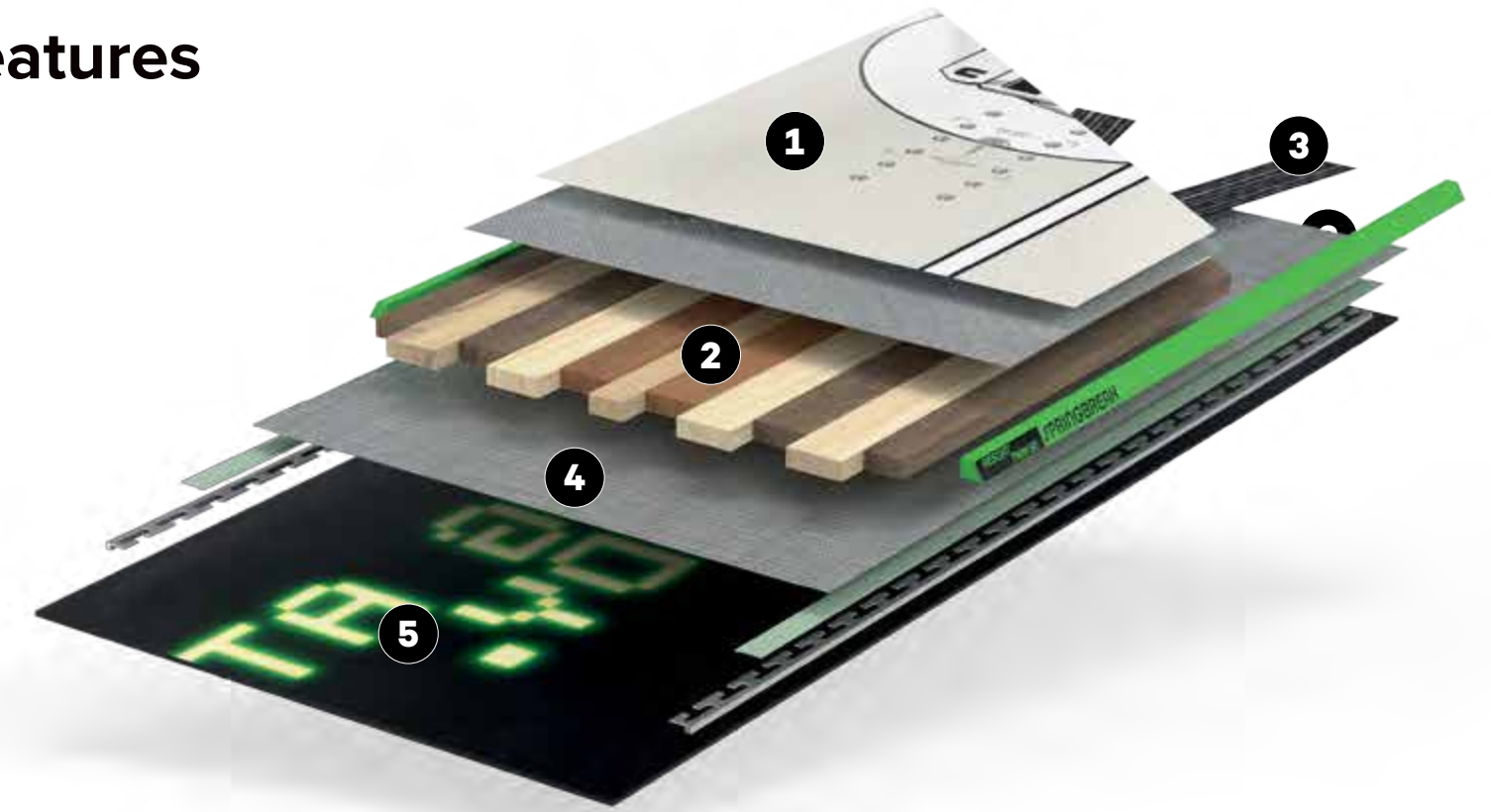

1
TOPSHEET TECH:
PLT Technology
• Screen
+ Gloss/Matte Print

2
CORE:
META CORE™

3
ADDITIVES:
4 x 30 mm
CARBON V-TECH
AMPLIFIERS

4
GLASS + RESIN:
HOLYSHEET™ TRI/BI
MAGIC BEAN™ RESIN

5
BASE:
POWDER DRIVE™
• Sublimation

• DEATH GRIP™ SIDECUT

CORE:
■ CARBON
■ BEECH
■ PAULOWNIA
■ POPLAR



With a Meta Core™, Carbon V-Tech Amplifiers, and a HolySheet™ Tri/Bi Fiberglass configuration the *Spring Break Resort Twin* delivers the pop and power demanded by freestyle park and resort riders.

NEW SERIES!

SB STAIRMASTER

Park + Resort / Twin / Traditional Camber

A legend in CAPiTA history, the *Stairmaster* debuted as a tough and affordable option for free-style snowboarders holding a more skate-style mentality to product. With a purist approach, they wanted a simple yet proven construction with no unnecessary additives—and they wanted to buy it at a price that made sense knowing it will be ridden hard. The graphic direction was led by Corey Smith, and before long, the *Stairmaster* became a rider favorite. In fact, it was one of our most widely ridden boards for years.

For 25/26, the *Stairmaster* is back. This time under the Spring Break Snowboards umbrella, once again aesthetically curated and under the creative direction of Dr. Smith.

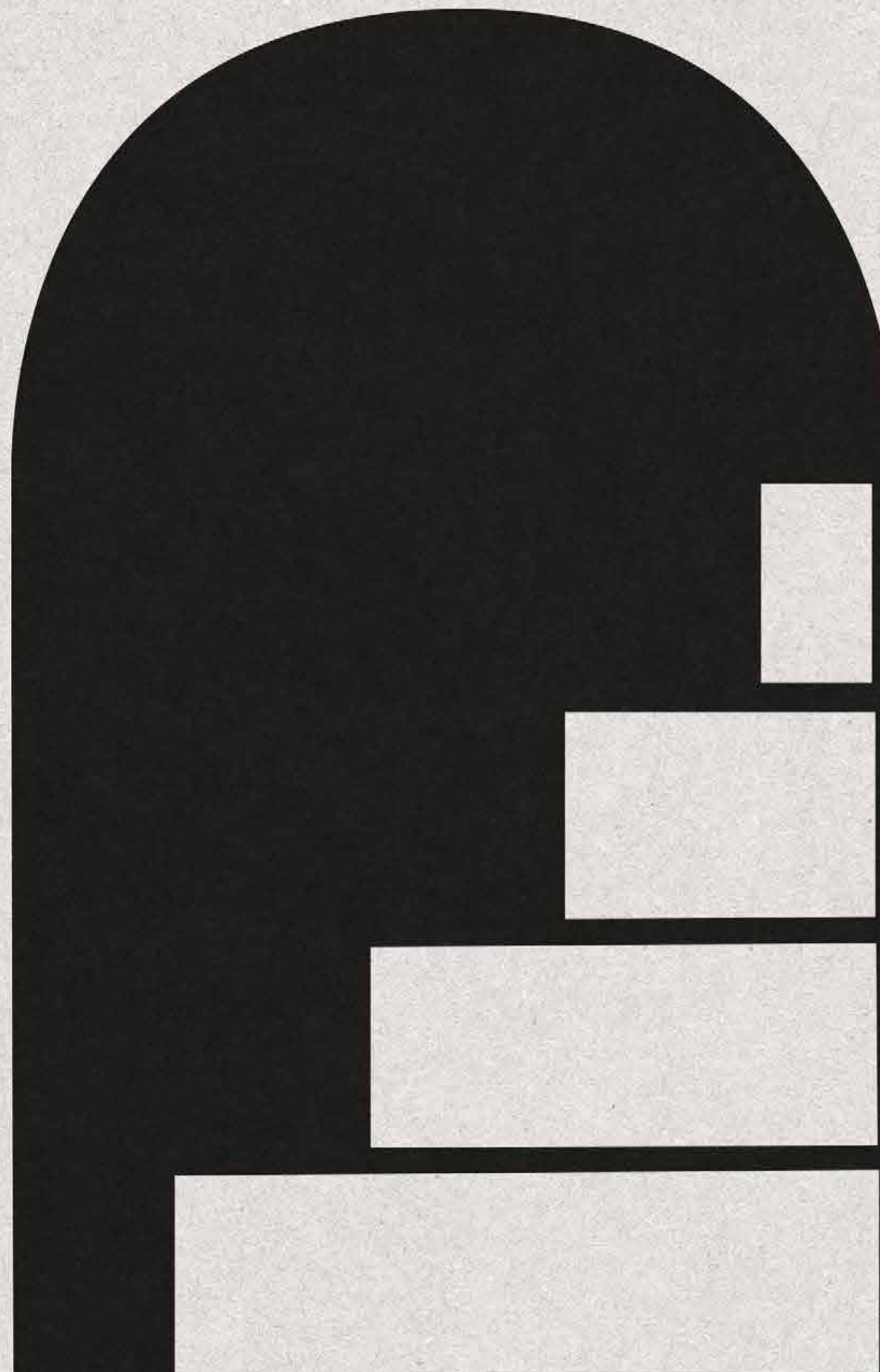

SB STAIRMASTER

Spring Break / Park + Resort / True Twin / Traditional Camber

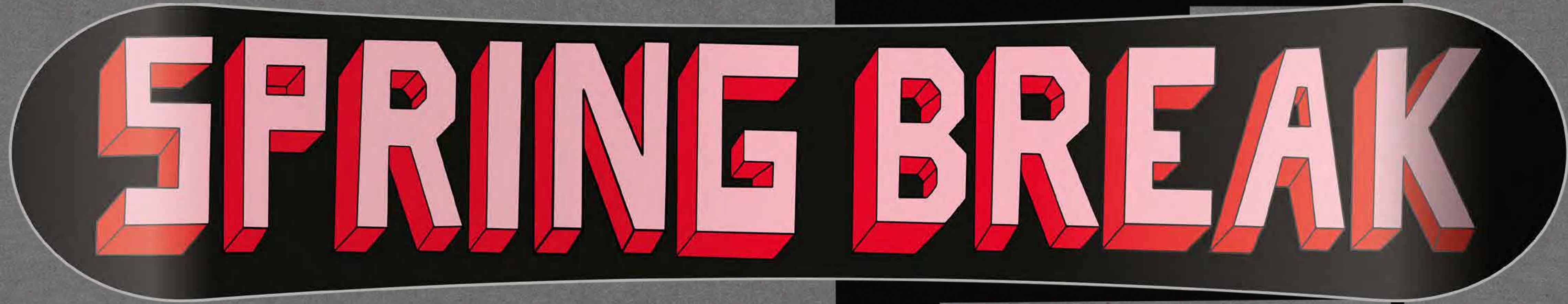

SB STAIRMASTER WIDE

Spring Break / Park + Resort / True Twin / Traditional Camber

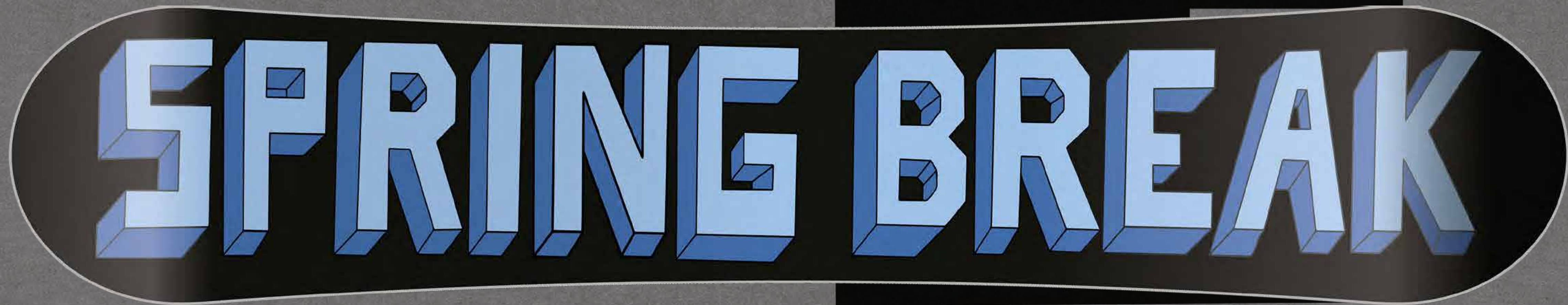

NEW SERIES! SPRING BREAK
STAIRMASTER



For the Spring Break fan seeking a progressive park and resort board.

RIDER TYPE:
Resort / Park

SHAPE:
True Twin

SIDECUT:
Radial

FLEX:
Twin 5.5

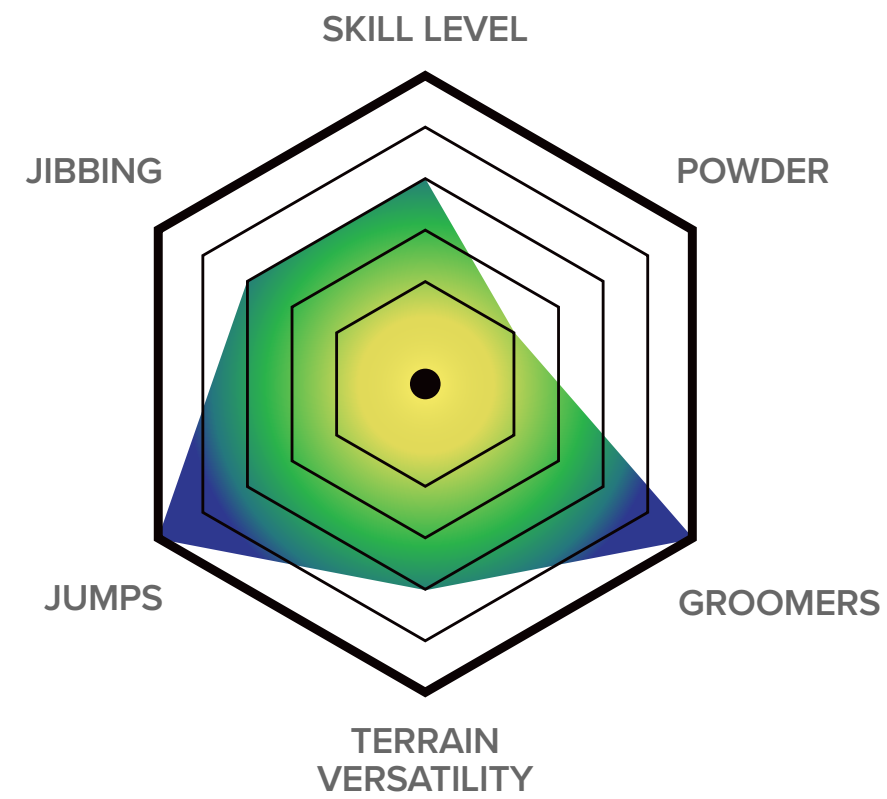

TRADITIONAL CAMBER:
Park V1

The *PARK V1* camber configuration zeros out a traditional camber approach 4 cm before the end of the sidecut. The small zero camber sections provide a more controlled ride while retaining the response and power of a cambered board.

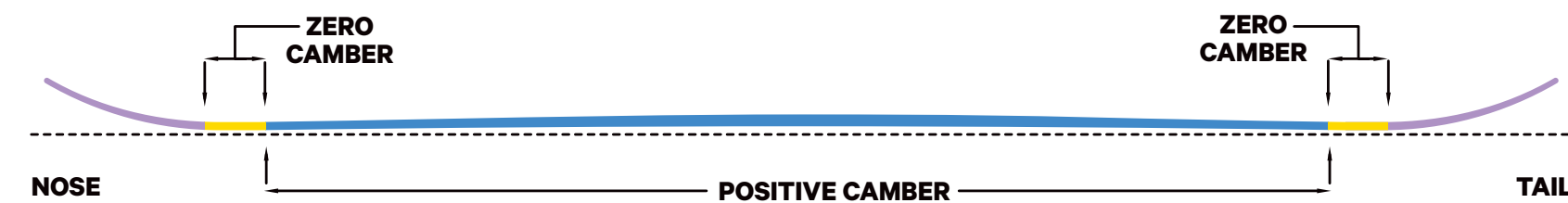

LENGTH	EFFECTIVE EDGE (mm)	WAIST	NOSE / TAIL	SIDECUT	REF. STANCE (cm / inches)	SUGGESTED WEIGHT (lbs / kg)
152	1185	25.2	29.5 / 29.5	7.9	53.3 / 21.0	100-160 / 45-72
154	1202	25.3	29.7 / 29.7	8.0	53.3 / 21.0	120-180 / 54-81
156	1220	25.5	29.9 / 29.9	8.1	55.9 / 22.0	130-190 / 59-86
158	1237	25.6	30.1 / 30.1	8.2	55.9 / 22.0	140-200 / 63-90
156 W	1220	26.0	30.4 / 30.4	8.1	53.3 / 21.0	150-210 / 68-95
158 W	1237	26.4	30.9 / 30.9	8.2	55.9 / 22.0	160-220 / 72-99

OVERVIEW

Tech Features

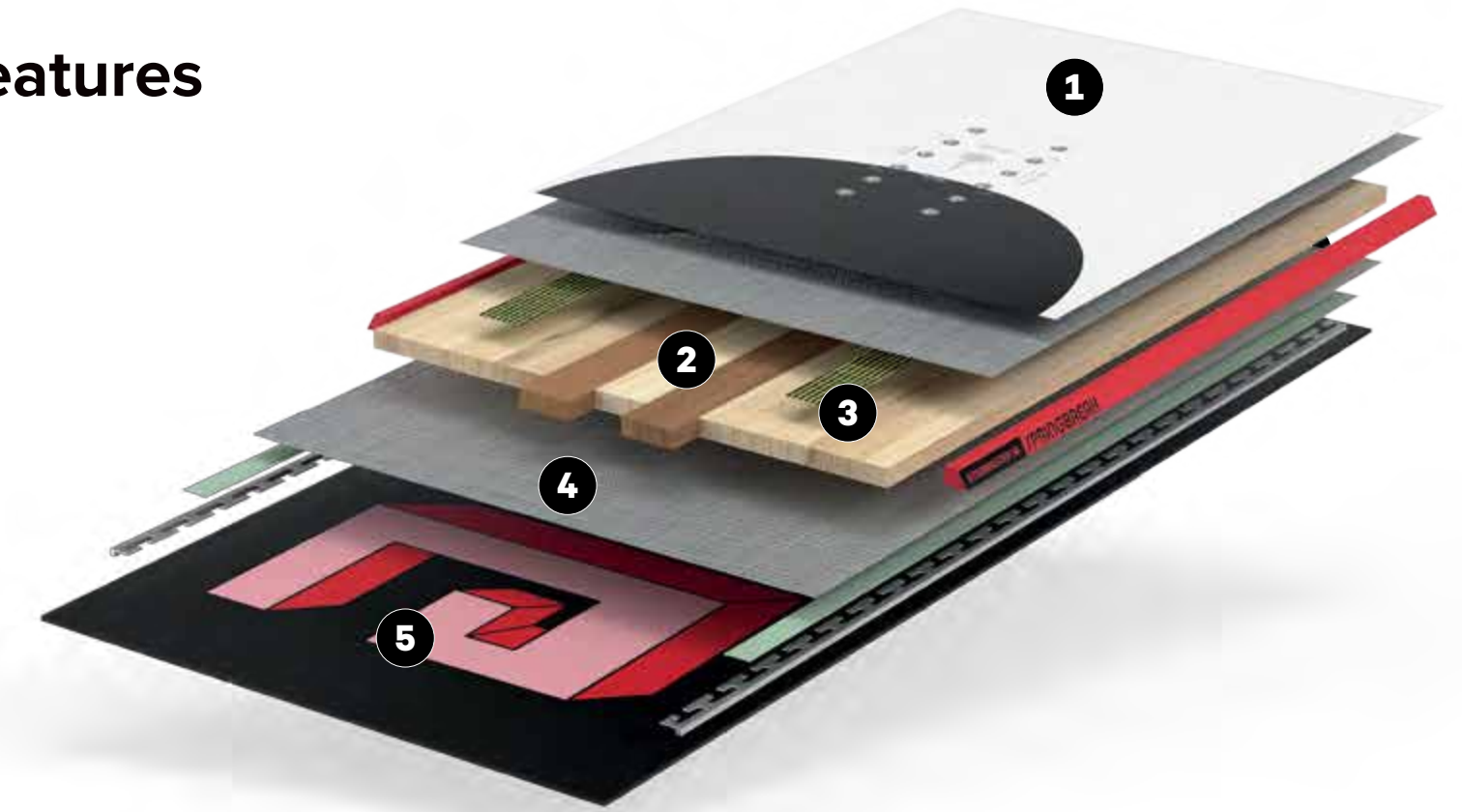

1 TOPSHEET TECH:
 • Screen + Gloss/Matte Print
 • Pearlescent Underlay

2 CORE:
DUAL CORE™

3 ADDITIVES:
 4 x 20 mm
CARBON ARAMID BOOSTERS

3 GLASS + RESIN:
**SPECIAL BLEND FIBERGLASS
 MAGIC BEAN™ RESIN**

6 BASE:
SUPERDRIVE™ ADV
 • Sublimation

CORE:
 ■ CARBON ARAMID
 ■ BEECH
 ■ POPLAR

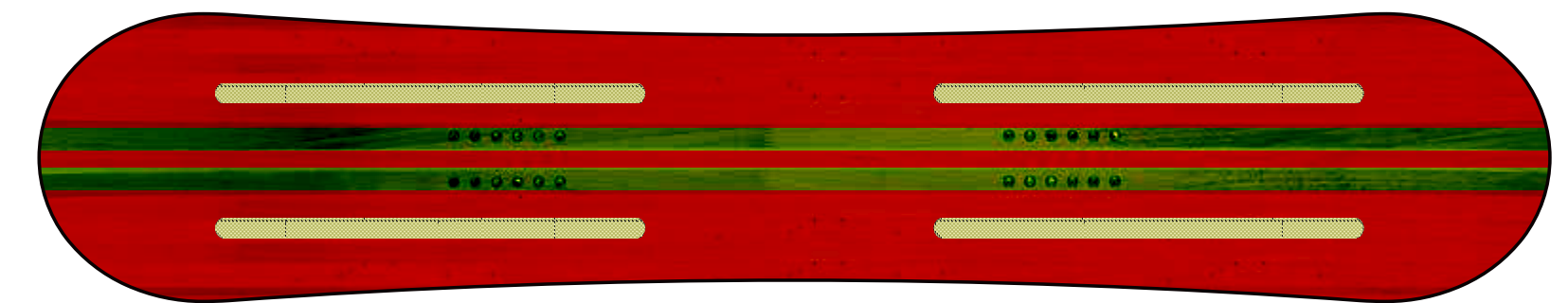

The new *Stairmaster* is an energetic park board with a budget friendly construction. It delivers the pop and power, demanded by progressive freestyle riders through with its tried and trusted combination of Dual Core™ and Special Blend Fiberglass further enhanced with 2 x 30 mm Carbon Aramid Boosters.

SB SLUSH SLASHERS

Powder + Resort / Directional / Hybrid Camber

The *Slush Slasher* is the playful mini-park and powder ripper that changed the game.

This innovative short-board rails turns on groomers, transitions, and in the park, and it's as fun on jibs as it is in the deep stuff. This board is sure to change your perspective on any terrain and put a smile on even the grumpiest skeptics.

The elongated nose plows over anything in its path, while its Vacation Tail lets you put these snow sharks on cruise control. With the *Slush Slasher*, the world is your seven-day weekend.

SPRING

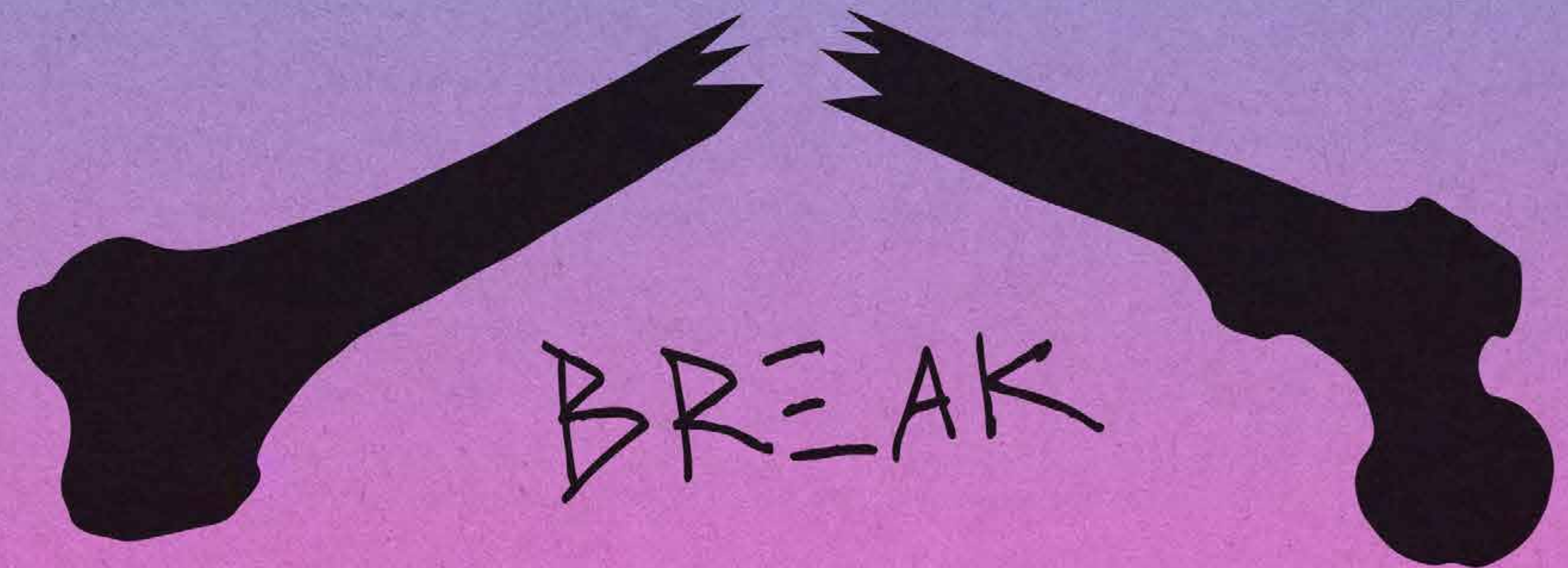

SB SLUSH SLASHERS 2.0

Spring Break / Powder + Resort / Directional / Hybrid Camber



SPRING BREAK SLUSH SLASHERS 2.0



The ultimate slush and powder board for all who love good vibes.

RIDER TYPE:
Powder / Resort

SHAPE:
Directional

SIDECUT:
Radial

FLEX:
**Directional
4**

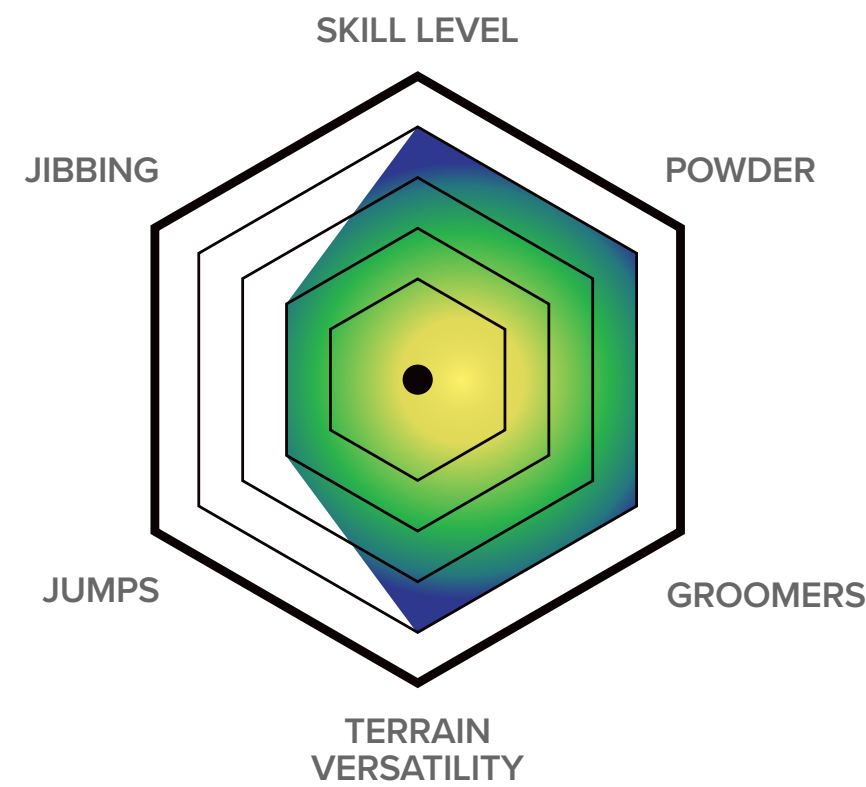

HYBRID CAMBER:
Surf Camber

The *SURF CAMBER* features smooth arcing tip and tails and camber through the inserts. The gentle low angle allows for maximum float and control.

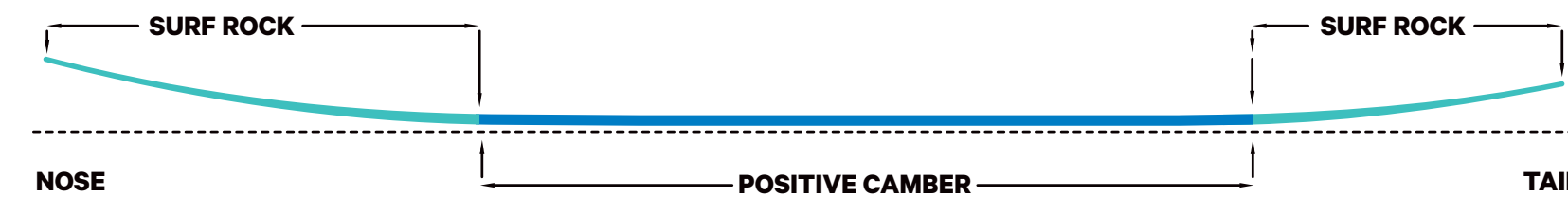

LENGTH	EFFECTIVE EDGE (mm)	WAIST	NOSE / TAIL	TAPER	SIDECUT	REF. STANCE (cm / inches)	SUGGESTED WEIGHT (lbs / kg)
143	1172	26.3	32.0 / 30.0	20.0	7.0	53.3 / 21.0	110-170 / 50-77
147	1211	26.4	32.5 / 30.0	25.0	7.2	55.9 / 22.0	130-180 / 59-82
151	1250	26.5	33.0 / 30.0	30.0	7.4	55.9 / 22.0	150-200 / 67-91
NEW! 155	1290	26.6	33.5 / 30.0	35.0	7.6	58.4 / 23.0	170-220 / 77-99

OVERVIEW

Tech Features

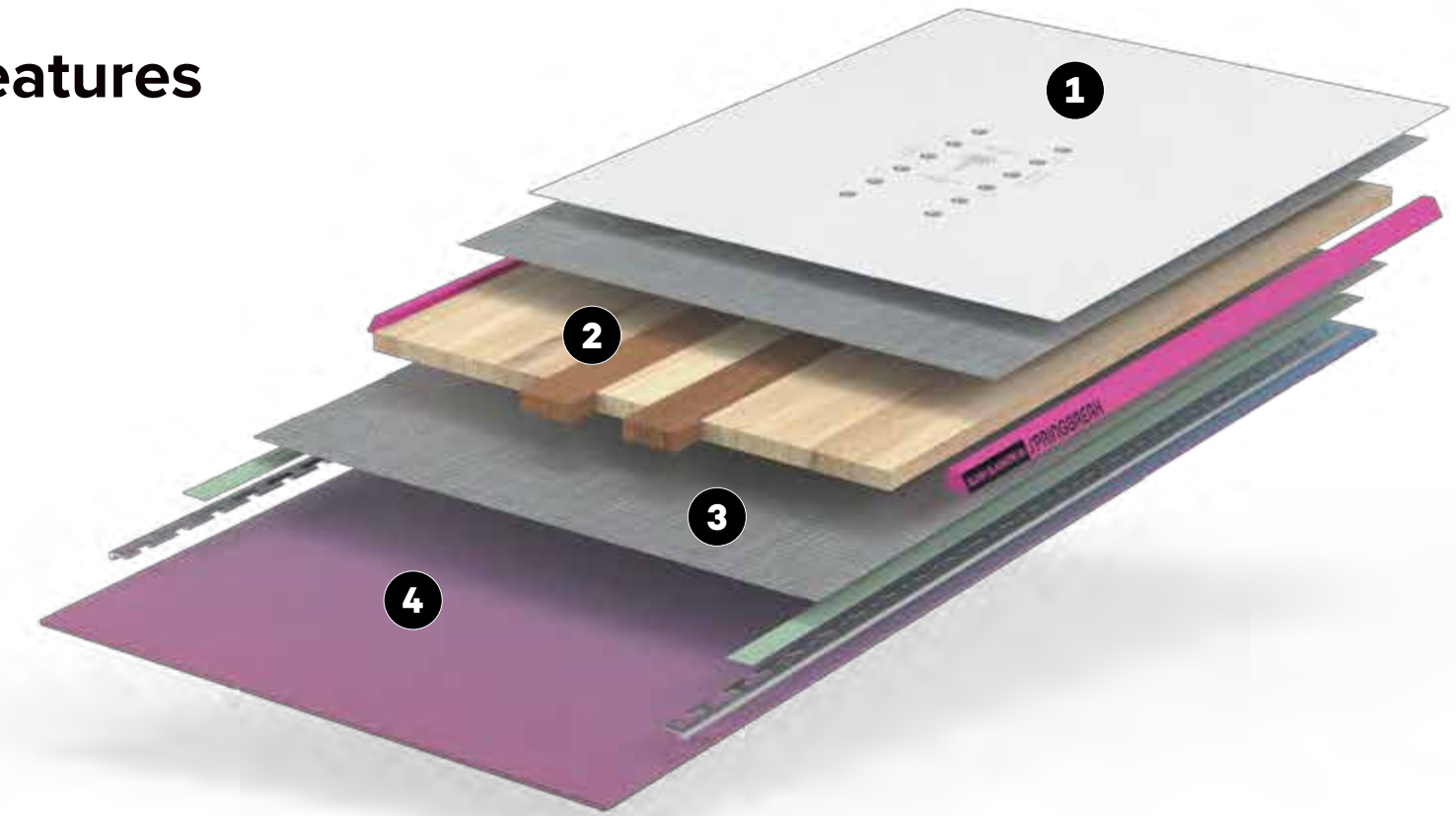

1 TOPSHEET TECH:
• Screen Print
• Metallic Underlay

2 CORE:
DUAL CORE™

3 GLASS + RESIN:
**SPECIAL BLEND FIBERGLASS
MAGIC BEAN™ RESIN**

4 BASE:
SUPERDRIVE™
• Sublimation

5 BASE TECH:
**INLAID ALLOY
SKID PLATES**

CORE:
■ BEECH
■ POPLAR



Experience the ultimate party board. Engineered with a Dual Core™, Special Blend Fiberglass configuration, SuperDrive™ base and an inlaid Alloy Skid Plate to protect the V-Shaped Vacation Tail™, the *Slush Slasher 2.0* is ready for high-speed carves, powder slashes and freestylin' all over the mountain.

RENTAL

R-SERIES

Radial / True Twin



RENTAL R-SERIES



With an easy to learn on camber and an easy to repair base the R-Series is the perfect addition to your rental fleet.

RIDER TYPE:
Freestyle

SHAPE:
True Twin

SIDECUT:
Radial

FLEX:
**Twin
4**

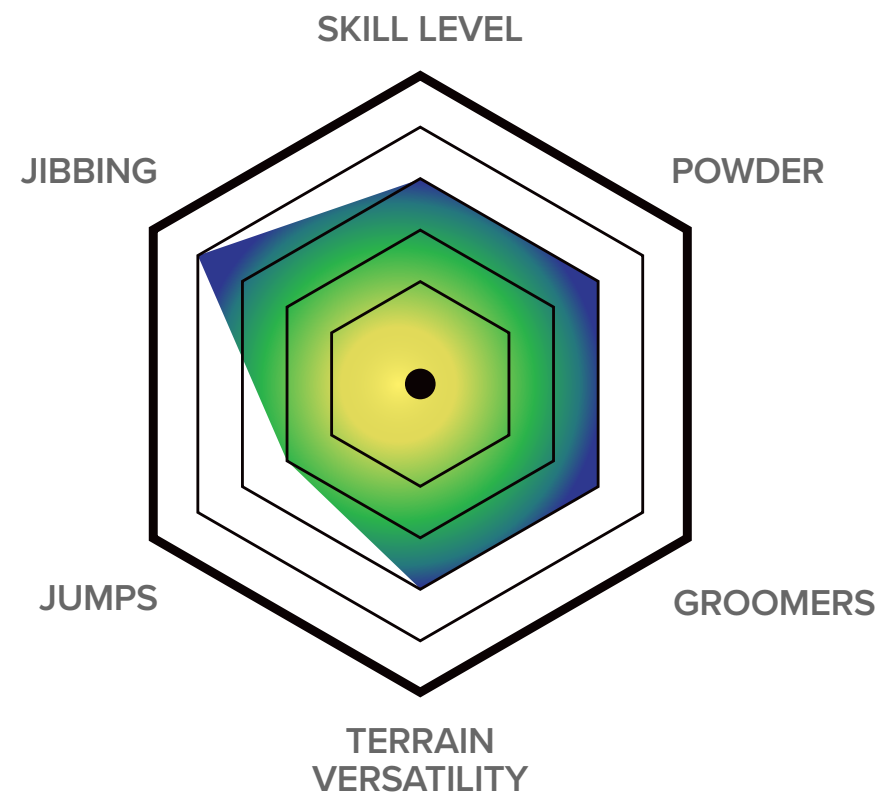

REVERSE CAMBER:
Park V2 + Flat Kick Tech

These versatile boards feature a dual reverse camber Flat Kick freestyle shape. A zero camber section throughout the insert area provides a stable skate-style feel, while elevated contact points turn on a dime and float effortlessly in powder.

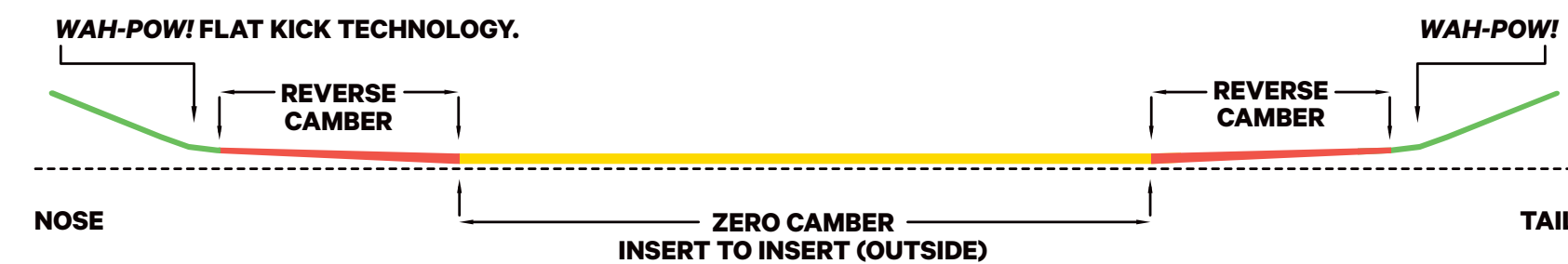

LENGTH	EFFECTIVE EDGE (mm)	WAIST	NOSE / TAIL	SIDECUT	REF. STANCE (cm / inches)	SUGGESTED WEIGHT (lbs / kg)
145	1154	24.6	29.0 / 29.0	7.4	50.8 / 20.0	80-120 / 36-54
149	1186	25.0	29.5 / 29.5	7.6	50.8 / 20.0	95-150 / 43-68
153	1218	25.4	30.0 / 30.0	7.8	53.3 / 21.0	110-170 / 49-77
157	1250	25.8	30.5 / 30.5	8.0	55.9 / 22.0	140-200+ / 63-90+
155 W	1234	26.1	30.8 / 30.8	7.9	55.9 / 22.0	130-190 / 59-86
157 W	1250	26.3	31.0 / 31.0	8.0	55.9 / 22.0	140-200 / 64-91
159 W	1265	26.5	31.2 / 31.2	8.2	55.9 / 22.0	150-210 / 68-95
162 W	1298	26.8	31.6 / 31.6	8.2	58.4 / 23.0	160-220+ / 72-99+

OVERVIEW

Tech Features

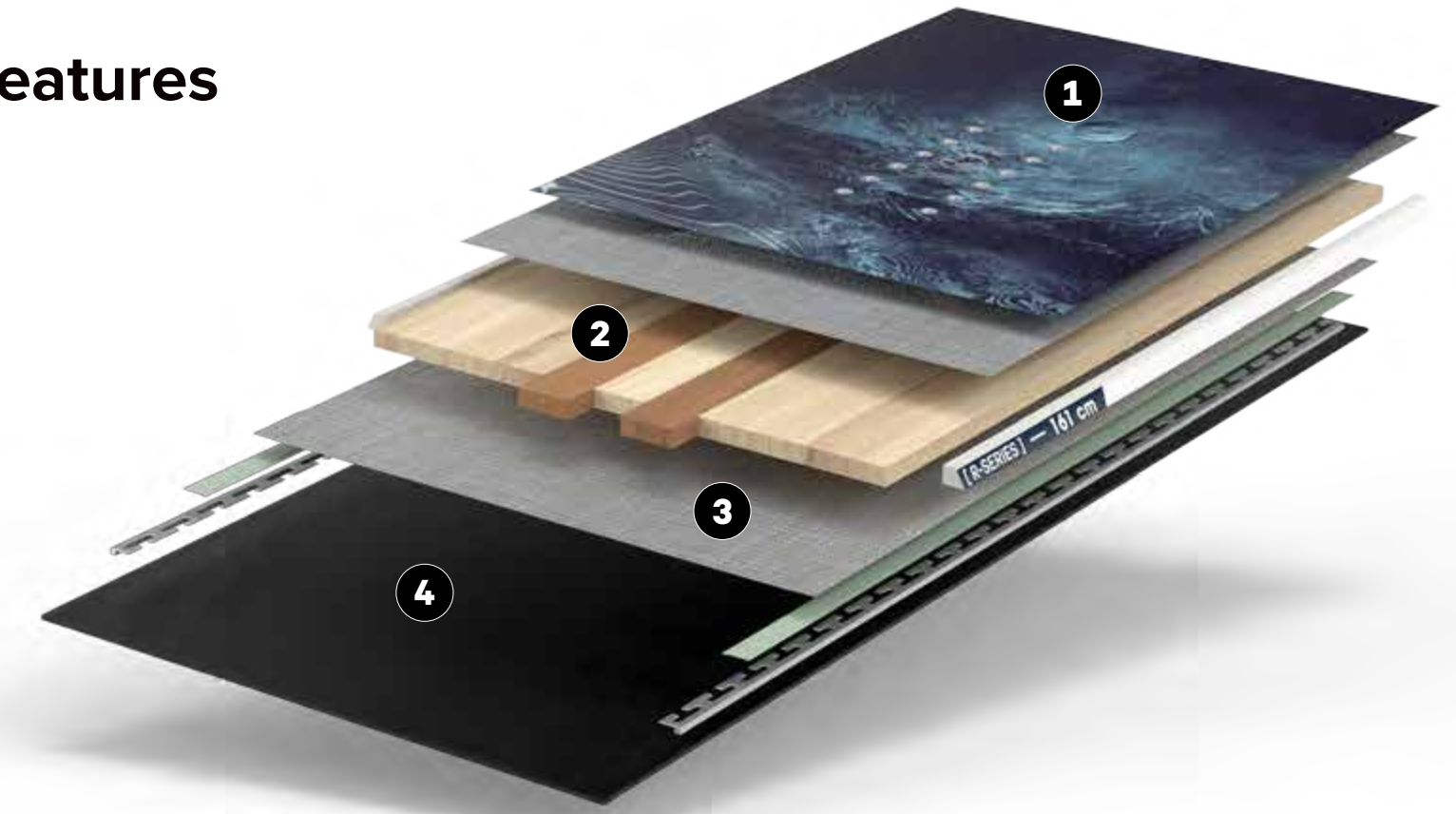

1
TOPSHEET TECH:
• Digital Print

2
CORE:
DUAL CORE™

3
GLASS + RESIN:
SPECIAL BLEND FIBERGLASS
MAGIC BEAN™ RESIN

4
BASE:
SUPERDRIVE™
• Digital Print

• BITTER END™ DEFLECTION TUNING

CORE:
■ BEECH
■ POPLAR



SOFTGOODS

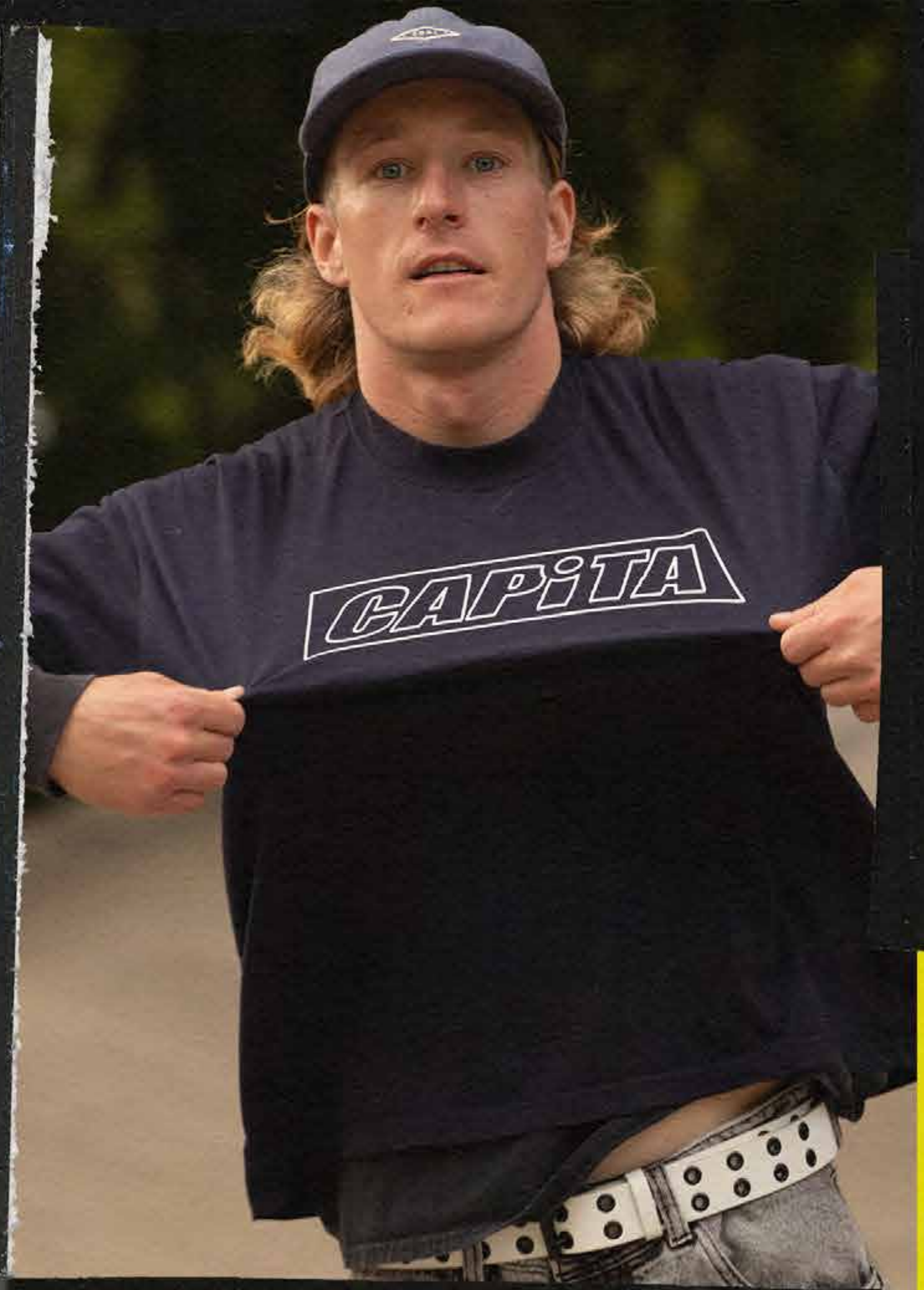

Longo Hood

Black

55/45 Soft spun
Cotton/Polyester

S / M / L / XL / XXL

- Relax fit
- Jersey-lined, two-piece hood
- Screenprinted graphics on sleeve, chest, and back



Fracture Hood

Light Olive

55/45 Soft spun
Cotton/Polyester

S / M / L / XL / XXL

- Relax fit
- Jersey-lined, two-piece hood
- Screenprinted graphics on chest and sleeve



Dharma Hood

Black

55/45 Soft spun
Cotton/Polyester

S / M / L / XL / XXL

- Relax fit
- Jersey-lined, two-piece hood
- Screenprinted graphics on chest and sleeve



Advanced Hood

Lavender

55/45 Soft spun
Cotton/Polyester

S / M / L / XL / XXL

- Relax fit
- Jersey-lined, two-piece hood
- Screenprinted graphics on chest and sleeve



Gravity Long Sleeve Tee

Light Gray
Blue

100% Cotton

S / M / L / XL / XXL

- Pre-laundered for minimal shrinkage
- Standard t-shirt fit
- Screenprinted graphics on chest and sleeve



Mothership Long Sleeve Tee

Black
Lavender

100% Cotton

S / M / L / XL / XXL

- Pre-laundered for minimal shrinkage
- Standard t-shirt fit
- Screenprinted graphics on chest and sleeve



Stack Tee

Off-white

100% Cotton

S / M / L / XL / XXL

- Pre-laundered for minimal shrinkage
- Standard t-shirt fit
- Screenprinted graphics on chest



Kazu Tee

Black

100% Cotton

S / M / L / XL / XXL

- Pre-laundered for minimal shrinkage
- Standard t-shirt fit
- Screenprinted graphics on chest and back



Skull Tee

Light Sage

100% Cotton

S / M / L / XL / XXL

- Pre-laundered for minimal shrinkage
- Standard t-shirt fit
- Screenprinted graphics on chest and back



Aeronaut Tee

Slate Blue

100% Cotton

S / M / L / XL / XXL

- Pre-laundered for minimal shrinkage
- Standard t-shirt fit
- Screenprinted graphics on chest and back



Outline Sweat Pants

Black

50/50
Cotton/Polyester

S / M / L / XL / XXL

- Elastic, self-fabric waistband and self-fabric cuffs
- Front pockets
- Screenprinted graphics on right thigh



Retro Tee

White

100% cotton

S / M / L / XL / XXL

- Pre-laundered for minimal shrinkage
- Standard t-shirt fit
- Screenprinted graphics on chest



Block Tee

Black

100% cotton

S / M / L / XL / XXL

- Pre-laundered for minimal shrinkage
- Standard t-shirt fit
- Screenprinted graphics on chest



Computer Long Sleeve Tee

White

100% cotton

S / M / L / XL / XXL

- Pre-laundered for minimal shrinkage
- Standard t-shirt fit
- Screenprinted graphics on chest and sleeve



Bones Hood

Black

55/45 soft spun
Cotton/polyester

S / M / L / XL / XXL

- Relax fit
- Jersey-lined, two-piece hood
- Screenprinted graphics on chest and sleeve



Mothership Hat

White

100% Cotton

OSFM

- Shallow fit
- Structureless
- Snap back



Connection Hat

Black

Polar fleece +
Nylon taslan

OSFM

- 5 panel
- Moisture wicking sweat band
- Shock cord adjuster



Fracture Beanie

Olive
Black

Acrylic

OSFM

- Skull fit



Worm Beanie

Gray
Black

Acrylic

OSFM

- Loose fit
- Thick knit for warmth



Dharma Stomp Pad

Black

EVA

- 12 cm x 12 cm
- Soft foam that squishes into tread of boot for a solid grip



MFG Board Bag

Red

100% Polyester

- Simple, unpadded board bag
- Fit boards up to 165 cm



Explorer Wheeled Board Bag

Red

100% Polyester

Dimensions: 165x20x33cm (65x7.9x13")
Volume: 110 l (6.713 cu. In.)

- Board divider
- 2 internal board straps
- 2 external accessory pockets
- Removable boot bag
- Internal mesh accessory pocket
- Durable 38mm webbing handles for rolling luggage with one hand.
- Durable and replaceable external Oversized wheels for stability.
- Full circle / 3D padded protection
- #10 YKK zipper
- Trifolds for storage and shipping

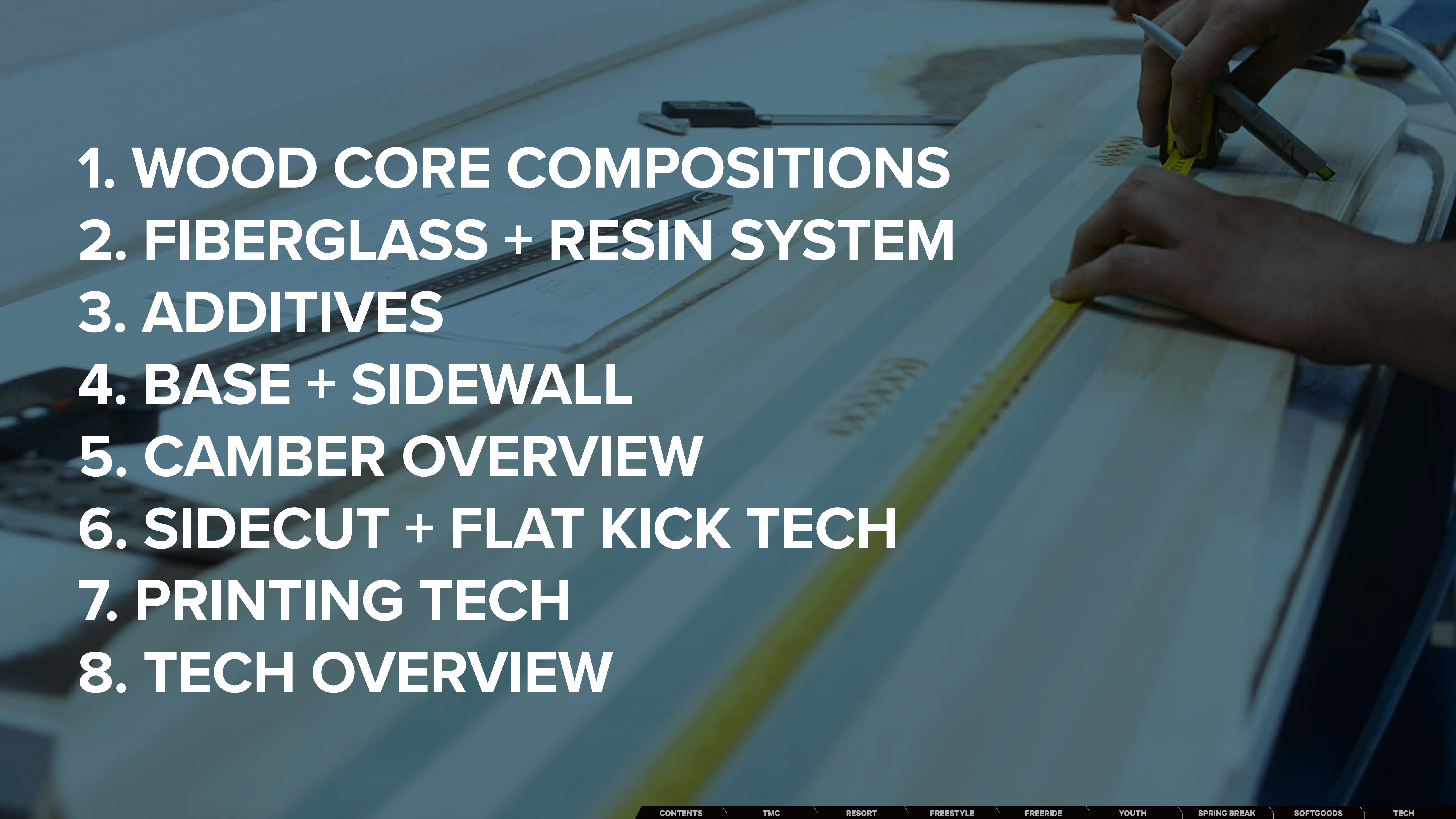

- 
- 1. WOOD CORE COMPOSITIONS**
 - 2. FIBERGLASS + RESIN SYSTEM**
 - 3. ADDITIVES**
 - 4. BASE + SIDEWALL**
 - 5. CAMBER OVERVIEW**
 - 6. SIDECUT + FLAT KICK TECH**
 - 7. PRINTING TECH**
 - 8. TECH OVERVIEW**

WOOD CORE COMPOSITIONS

A snowboard's **wood core** is the heart and soul of the riding experience.

This essential element determines the key character traits of a snowboard and functions as the primary building block for everything else that goes into a board. Every *CAPiTA* deck starts off with a specialized wood core allowing for uniform flex, greater turning control, and incredibly fast response. Different species of wood, along with custom core profiles, help give each deck a unique feel and targeted flex. We have engineered a series of wood core compositions, each with distinctive characteristics, to ensure that we have your ideal snowboard.



MAIN LINE

1

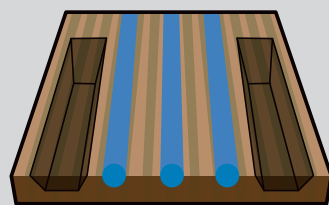

3D THERMOPOLYMER STARSHIP CORE™

■ PET ■ MEGA-PREMIUM POPLAR

- MEGA DEATH (NO 3D)
- MEGA MERC
- SUPER D.O.A.

Utilizing an advanced electronic sorting system allows us to select mega-premium, reforestation certified, *Poplar* graded by weight and grain consistency. Comparable to *Paulownia* in strength to weight ratio, this core retains the poppiness of *Poplar*, and then achieves a signature feel by adding bonded post-consumer recycled *Thermopolymer* channels to form an advanced hybrid core. This mega-premium core will blast you into space and beyond.

2

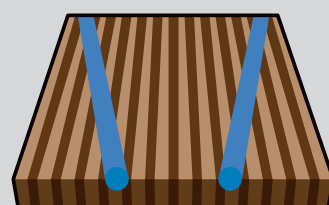

THERMOPOLYMER HOVER CORE™

■ PET ■ PAULOWNIA
■ POPLAR

- THE BLACK SNOWBOARD OF DEATH

Enhanced with bonded post-consumer recycled *Thermopolymer* channels into ultra-lightweight select grain wood core strips, the *THERMOPOLYMER HOVER Core™* is extremely light and strong with excellent dampening properties.

3

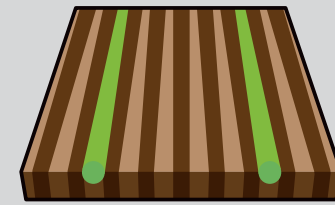

PANDA HOVER CORE™

■ PAULOWNIA ■ POPLAR
■ BAMBOO

- AERONAUT
- KAZU KOKUBO PRO

Ultra lightweight core enhanced with *Bamboo Power Rods™* for maximum power and response.

4

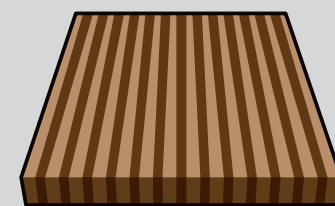

HOVER CORE™

■ PAULOWNIA ■ POPLAR

- MERCURY
- THE OUTSIDERS
- THE NAVIGATOR
- SB POWDER RACERS

An energetic premium core that is ultralight and strong with excellent dampening properties.

5

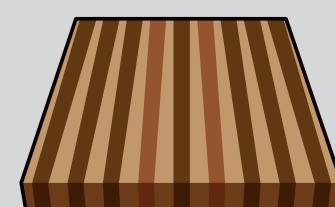

META CORE™

■ PAULOWNIA ■ POPLAR
■ BEECH

- INDOOR SURVIVAL
- THE EQUALIZER
- SB POWDER TWIN
- SB RESORT TWIN

We took our extremely lightweight *P2 Superlight Core™*, added high bending and shock absorbing *Beech* stringers running through the inserts for increased strength and even snappier pop.

6

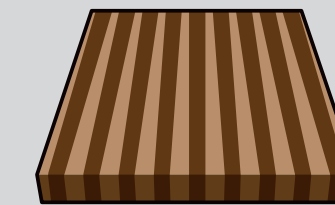

P2 SUPERLIGHT CORE™

■ PAULOWNIA ■ POPLAR

- D.O.A.
- BIRDS OF A FEATHER
- ULTRAFAEAR

Extremely lightweight and versatile core combined with high impact resistance and maximum pop.

7

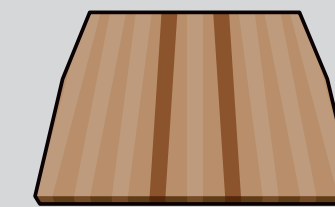

MULTIZONE CORE™

■ BEECH ■ POPLAR

- OUTERSPACE LIVING
- PARADISE

Poppy lightweight *Poplar* core combined with *Beech* for increased power and durability. Newly reengineered to taper between the insert packs for a more forgiving flex.

8



DUAL CORE™

■ BEECH ■ POPLAR

- PATHFINDER (CAM)
- PATHFINDER (REV)
- SPACE METAL FANTASY
- SB SLUSH SLASHER 2.0
- R-SERIES

Poppy lightweight *Poplar* core combined with *Beech* for increased power and durability.

8

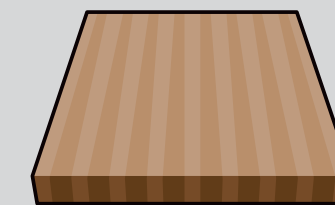

SELECT 2.0 CORE™

■ POPLAR

- CHILDREN OF THE POW
- CHILDREN OF THE GNAR
- JESS KIMURA MINI
- SCOTT STEVENS MINI

Poppy lightweight core with no irregularities for uniform flex and consistency. New wood core profiling for youth specific weight and flex optimization!

POWDER / SPLIT

1

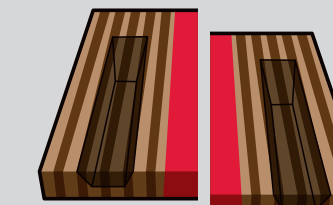

3D ASCEND 1 SPLIT CORE™

■ PAULOWNIA ■ POPLAR

- MEGA SPLIT

Mega-premium *Poplar* graded by weight and consistency aligned with *Paulownia* and an *ABS* centerline providing optimal strength to weight ratio. This high-end split specific core achieves a signature feel by utilizing a higher volume of thinner pressure-bonded *Paulownia* wood core strips for an ultra light weight chassis.

2

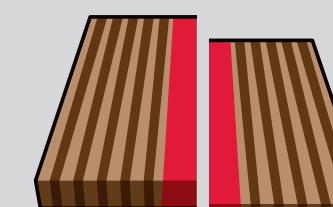

3D ASCEND 2 SPLIT CORE™

■ PAULOWNIA ■ POPLAR

- NAVIGATOR SPLIT

Premium weight-graded *Poplar* aligned with *Paulownia* and an *ABS* centerline resulting in a high-end split specific core. This core retains the primary poppiness of *Poplar* while remaining lightweight due to pressure-bonded dual-species wood core strips.

3

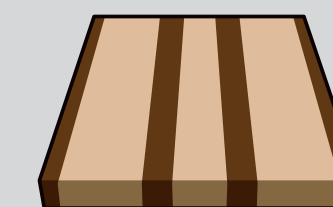

SURFLITE 4.0 CORE™

■ PAULOWNIA ■ MEGA-PREMIUM POPLAR

- SB POWDER GLIDER

Replacing balsa with ultra wide zones of flyweight *Paulownia*, and premium *Poplar*, we've managed to maintain the ultralight weight of the *SURFLITE* core while dramatically increasing its strength and durability.

FIBERGLASS

Laminated fiberglass is a key component when controlling the **strength and flex** of our boards.

Laminated fiberglass is used on the top and bottom of a board's wood core to protect it from water damage and is also a key component when controlling the strength and flex of our boards. When applying the resin, we use a mechanized dispensing system which accurately provides a calculated amount of resin per board to ensure the proper resin to glass ratio is being achieved. This process eliminates potential dry spots, preventing delamination and ensures no weight is added from excess resin. All *CAPiTA* boards are made this way and feature one of the following glass and resin configurations.



HYBRID HOLYSHEET™

Introducing the latest breakthrough from The MotherShip™: the *HYBRID HOLYSHEET™*. This cutting-edge development is the result of a collaborative effort with our glass supplier. We've ingeniously interwoven carbon additives directly into our *HOLYSHEET™* fiberglass, leading to a substantial enhancement in precision during layup and a notable reduction in weight.

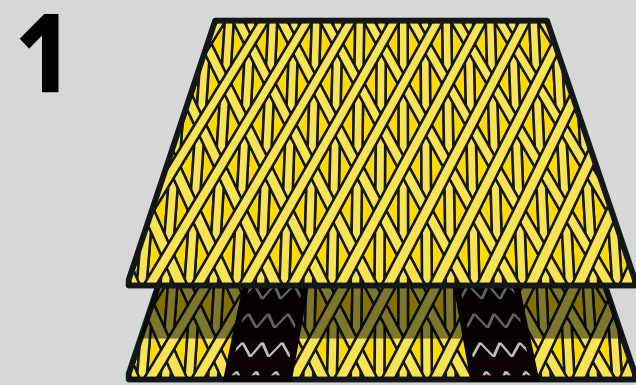

HYBRID HOLYSHEET™ TRI/TRI MEGACARBON™ / SUPERCARBON™

- MEGA MERC
- SUPER D.O.A.

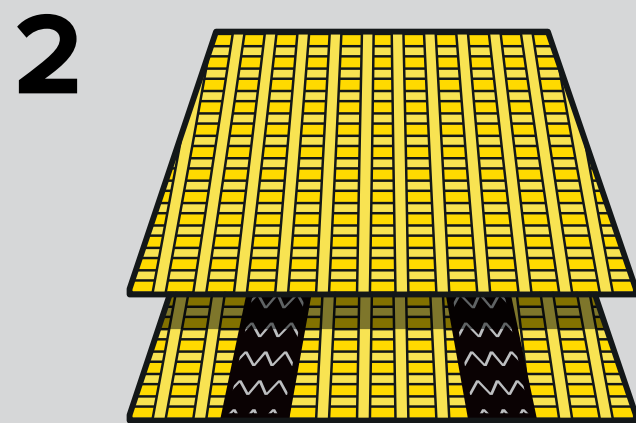

HYBRID HOLYSHEET™ BI/BI CARBON

- D.O.A.
- BIRDS OF A FEATHER
- **NEW!** ULTRAFEAR

HOLYSHEET™

The *HOLYSHEET™* fiberglass configuration features fiber weaves with a high tensile strength and low modulus of elasticity. With a higher roving count in the same weight of glass, you can have a stronger and more responsive board without adding extra weight. At the highest level, *Triaxial* fiberglass is placed on both the top and bottom of the core providing maximum strength, durability and performance, while many of our most sought after models feature *Triaxial* fiberglass on top of the core and *Biaxial* fiberglass beneath, creating a perfectly blended ride while increasing strength and durability. Combine one of these three layups with the *MAGIC BEAN™* resin and one of the many additives we have available, and you get an incredibly high performing board tailored to meet your style of riding.

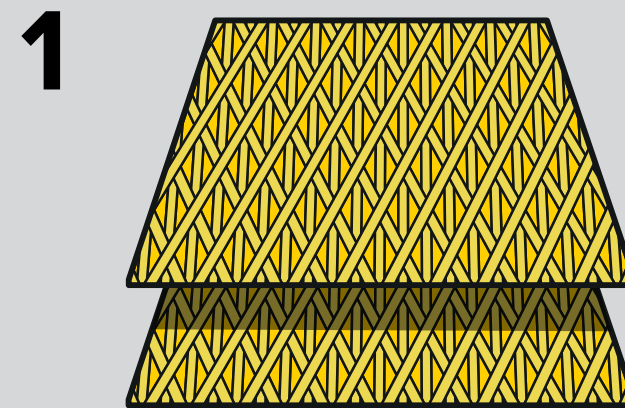

HOLYSHEET™ TRI/TRI FIBERGLASS

- THE BLACK SNOWBOARD OF DEATH
- SB POWDER GLIDER
- SB POWDER RACER SPLIT
- NAVIGATOR SPLIT

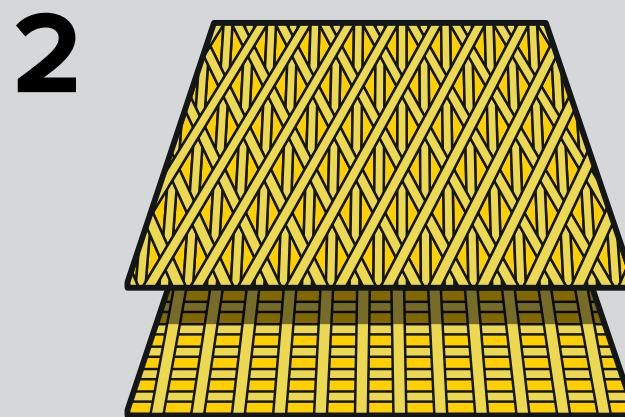

HOLYSHEET™ FIBERGLASS

- AERONAUT
- KAZU KOKUBO PRO
- MERCURY
- SCOTT STEVENS PRO
- THE OUTSIDERS
- INDOOR SURVIVAL
- THE NAVIGATOR
- THE EQUALIZER BY JESS KIMURA
- ULTRAFEAR
- SB POWDER RACERS
- SB POWDER TWIN
- SB RESORT TWIN

SPECIAL BLEND

SPECIAL BLEND is an eco-friendly wet lay-up process that uses our *MAGIC BEAN™* resin component requiring lower consumption of energy and yielding higher technical properties. This adhesion process improves the factory's working environment, as it does not contain some of the same harsh chemical characteristics used in resins at other factories around the world. This configuration uses an optimum blend of 626g/m² *Biaxial* fiberglass laminated in conjunction with structural additives to customize performance objectives.

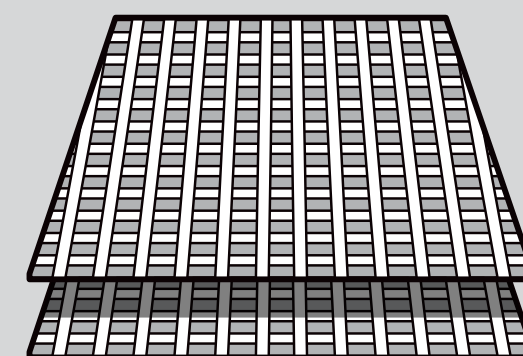

SPECIAL BLEND FIBERGLASS

- OUTERSPACE LIVING
- PARADISE
- PATHFINDER
- SPACE METAL FANTASY
- SB SLUSH SLASHERS 2.0
- CHILDREN OF THE POW
- CHILDREN OF THE GNAR

RESIN SYSTEM

Resin is an essential production component that is not only paramount to the dry weight and on-snow response of a snowboard, but also to the production process and environmental impact as well. Our industry first *MAGIC BEAN™* resin is unique to snowboard production as it has been formulated to require lower process temperatures. A lower temperature requirement in the press equals less energy needed to make each board. This system plays a key role in the high efficiency of our production facility and aligns with our sustainable initiatives.

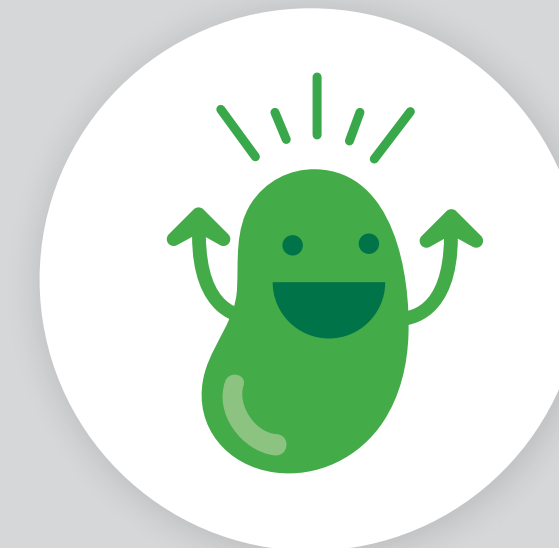

MAGIC BEAN™ RESIN

• ALL BOARDS EXCEPT MEGA DEATH AND MEGA SPLIT
Developed over a three-year span, this advanced resin system has a bio-content of 60% renewable, agricultural raw material. It is plant based that does not compete with primary food sources and is produced with no waste or greenhouse emissions. In production, it has a low-temperature requirement with a high yield output. This resin system is poppy, powerful, and extremely durable. *MAGIC BEAN™* resin yields much stronger and more rigid qualities allowing us to decrease the wood core thickness. Our focus is to save wood core weight by increasing resin performance. This means you get a lighter board while achieving higher energy return.

ADDITIVES



TOPSHEET

1

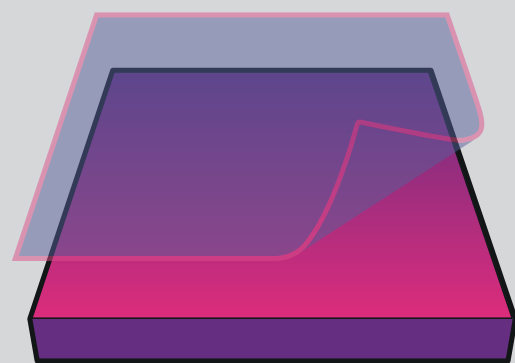

MEGALITE SKIN™ TOPSHEET

- MEGA MERC
- MEGA SPLIT

Super thin yet durable matte lamina for 60% weight reduction over our regular topsheets.

2

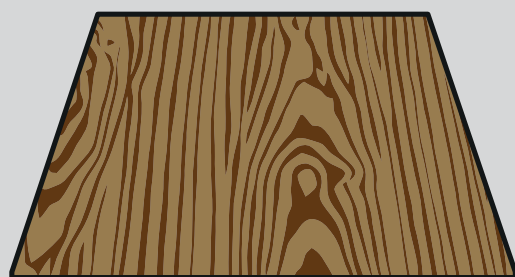

SKINLESS™ CORE ASH WOODGRAIN TOPSHEET

- THE BLACK SNOWBOARD OF DEATH
- KAZU KOKUBO PRO

Specially treated pure wood veneer topsheet with a unique tactile feel that is 220gm lighter than the standard process.

PERFORMANCE ENHANCER

1

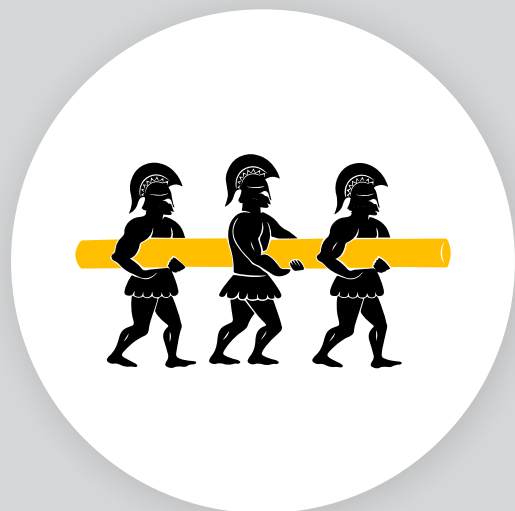

CARBON FLEECE POWER SHIELD™

- THE BLACK SNOWBOARD OF DEATH

With two *Carbon Fleece* power pads underfoot, maximum thrusting power is achieved for ollies and stability under varied-terrain while torsional forgiveness allows for ease of command while in battle.

2



CARBONFLAX™ V-TECH AMPLIFIER

- THE BLACK SNOWBOARD OF DEATH
- AERONAUT
- KAZU KOKUBO PRO
- MERCURY

CARBONFLAX™ is a next-generation natural flax fiber woven with carbon strands that is featured in our high-end snowboard constructions. This fusion tape brings the best of two worlds: the reactive energy of carbon and the lightweight and dampening aspects of flax. The two fibers are highly compatible since they have similar properties regarding thermal expansion and failure strain, creating a uniformly flexing reinforcement that's light, snappy and durable all in one.

3

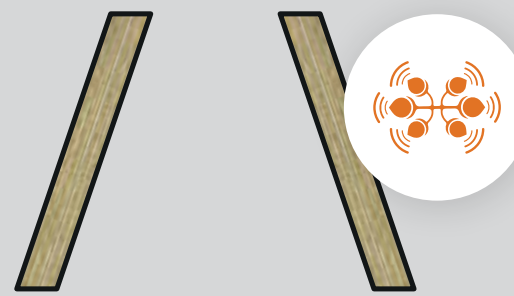

TECHNORA™ FLAX BOOSTERS

- SB POWDER RACER SPLIT
- SB POWDER RACERS
- THE OUTSIDERS
- THE NAVIGATOR
- THE EQUALIZER BY JESS KIMURA
- NAVIGATOR SPLIT

With an excellent tensile strength and fatigue resistance, *Technora™* is an aramid fiber that functions as a shock absorber and energy source when integrated into a snowboard construction layup. We have interwoven *Technora™* with an extremely lightweight and all-natural *Flax* fiber to invigorate every construction combination for maximum turning and ollie power.

4

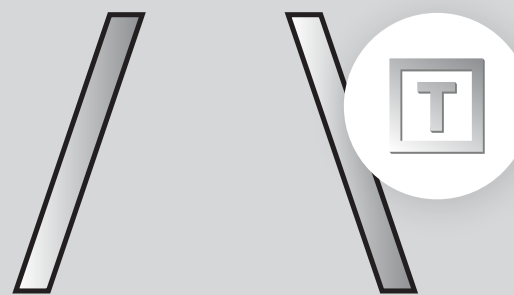

TITANAL CENTERLINE BOOSTER

- INDOOR SURVIVAL

Full length *Titanal* centerline that guarantees optimum stability and imparts ideal dampening properties.

5

CARBON FIBER

Known for its rigidity, high-tensile strength, low weight, high-temperature tolerance, and low thermal expansion, *Carbon Fiber* is one of the most popular materials used in today's high-performance applications. We increase power and response on a wide range of models by integrating different adaptations of carbon fiber thickness, width, weight, or weave while ensuring our boards remain ultralight.

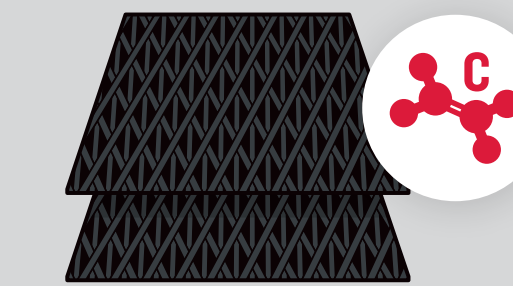

PURE MEGACARBON™

- MEGA DEATH
- MEGA SPLIT



MEGACARBON™ ARRAY

- MEGA MERC

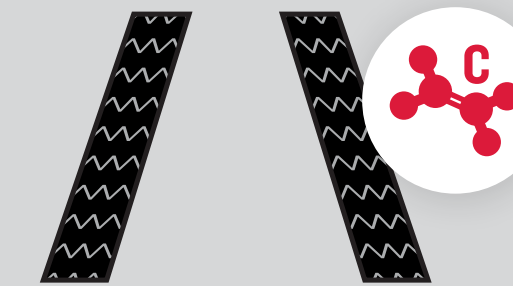

SUPERCARBON™

- SUPER D.O.A.

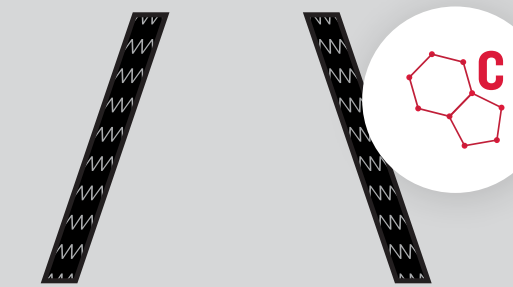

CARBON FIBER

- SB POWDER TWIN
- SB RESORT TWIN
- D.O.A.
- BIRDS OF A FEATHER
- THE NAVIGATOR

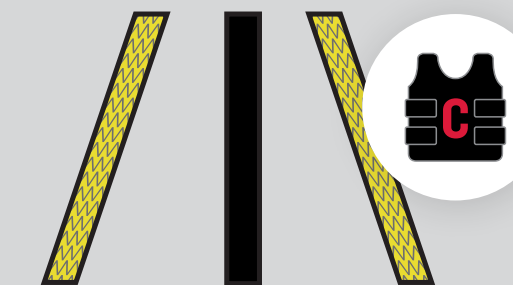

CARBON ARAMID

- ULTRAFEAR
- OUTERSPACE LIVING
- PARADISE

BASE + SIDEWALL (MATERIAL/TECH)

There are two basic types of base material used in our industry: *extruded* and *sintered*.

If you don't like to wax often and want something lower maintenance, extruded is for you. If you are more interested in going faster for longer and actually wax your board, sintered is your base. We offer unique variations of both compositions that reflect Polyethylene density, hardness, wax retention, and waxed—or unwaxed—speed.



SINTERED

1



MEGADRIVE™ XT BASE

- MEGA SPLIT
- MEGA DEATH (XT)
- MEGA MERC (XT)

Striving to kit out our MEGA line-up with the most advanced and premium components, the all new MEGADRIVE™ base is as fast as science can make it. This is a pure race base composed of UHMW polyethylene modified with high carbon content and special fluoro additives for lightspeed gliding in a wide range of conditions. We have increased the thickness of our XT bases for enhanced durability.

2



HYPERDRIVE™ / ADV XT BASE

- NEW! SUPER D.O.A. (ADV XT)
- NEW! THE BLACK SNOWBOARD OF DEATH (ADV XT)
- NEW! AERONAUT (ADV XT)
- NEW! KAZU KOKUBO PRO (ADV XT)
- MERCURY
- THE OUTSIDERS
- NEW! THE NAVIGATOR
- NEW! NAVIGATOR SPLIT

Custom formulated and exclusive to *The Mother-Ship*, our engineers have worked tirelessly with the world's leading polyethylene running base supplier to create HYPERDRIVE™. With exceptional anti-friction properties due to high molecular mass and specialized processing aids, this sintered material has a proprietary composition and is beyond fast. Our loyal fans charge hard, and we have integrated the fastest, meanest base available. We have increased the thickness of our XT bases for enhanced durability.

SINTRUDED

1



POWDER DRIVE™ BASE

- SB POWDER GLIDER
- SB POWDER RACER SPLIT
- SB POWDER RACERS
- SB POWDER TWIN
- SB RESORT TWIN

Dynamic and durable, easy to maintain and reliable, this base material is electric through the trees and fast over the flats. Featuring attributes of both sintered and extruded base material the POWDER DRIVE™ base was exclusively formulated for the extra-wide chassis of the Spring Break Powder Division and were designed with the powder lifestyle in mind.

SINTRUDED

2



QUANTUM DRIVE™ BASE

- INDOOR SURVIVAL
- THE EQUALIZER BY JESS KIMURA
- DEFENDERS OF AWESOME
- BIRDS OF A FEATHER

The QUANTUM DRIVE™ running base is formulated with a progressive blend of compressed ultra-high-molecular-weight polyethylene. As an evolution from the already blazing fast SUPERDRIVE™, this running base features higher density for durability and absorbs more wax to wick longer and ride faster. Properly maintained sintered bases are fast, durable, and are the preferred choice of many high-end enthusiasts worldwide.

3



SUPERDRIVE™ / ADV BASE

- ULTRAFEAR (ADV)
- OUTERSPACE LIVING (ADV)
- PARADISE (ADV)
- PATHFINDER
- SPACE METAL FANTASY
- SB SLUSH SLASHERS 2.0

The SUPERDRIVE™ base material lives in the *Sintruded* category of boards that deliver benefits of both sintered and extruded bases. These bases take the characteristics and manufacturing techniques used in creating extruded base material, but due to higher pressure and temperature, increase the surface hardness to levels near most sintered bases. This expands the durability and surface strength, creating a base that will be more durable when jibbing and ripping around the mountain while retaining a low maintenance and carefree lifespan of the board. SUPERDRIVE™ is the benchmark for sintered material while SUPERDRIVE™ ADV yields higher durability and glide performance.

EXTRUDED



XXX[TRUDED]™ BASE

- CHILDREN OF THE POW
- CHILDREN OF THE GNAR
- SCOTT STEVENS MINI
- JESS KIMURA MINI
- MICRO MINI

If there's one thing we know about kids and groms, it's that they can be hard on their gear and they're never going to wax their snowboard. The XXX[TRUDED] base material is a high density extruded base material that is durable and low maintenance. The relative surface strength equals a base that will last longer and be more durable when jibbing and ripping around the mountain.

BASE TECH

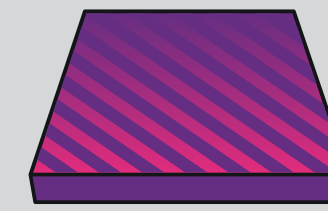

MOONSHOT OMNI-TUNE™

- MEGA SPLIT
- MEGA DEATH
- MEGA MERC
- SUPER D.O.A.
- THE BLACK SNOWBOARD OF DEATH
- KAZU KOKUBO PRO

The MOONSHOT OMNI-TUNE™ is an aftermarket high-performance race-base structure that wicks water from your base at a 45-degree angle making these boards fast as f*#k to the lift line or to the finish line.

SIDEWALL TECH

1

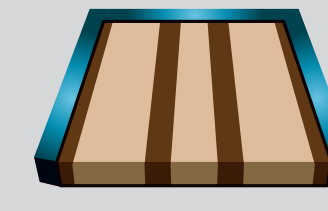

WATERJET CUT ABS1000 SIDEWALLS

- SB POWDER GLIDER

Waterjet cutting produces a stronger ABS sidewall as the ABS is milled to design specification rather than bent into its final shape. The process also produces zero heat thus the material's chemical structure remains intact.

2



1.5 mm FULL CORK EDGE DAMPENING SYSTEM

- ULTRAFEAR

Damp, durable, and lighter than rubber, our CORK EDGE DAMPENING SYSTEM is placed in between the steel edge and the ABS sidewall for increased protection from blunt force impacts. The ULTRAFEAR and the Scott Stevens Pro both feature a full contact length system for full edge dampening and protection.

3

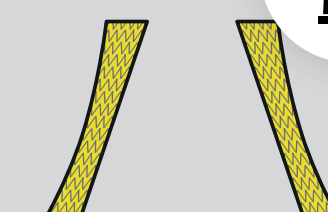

FORTRESS™ KEVLAR BOUND SIDEWALLS

- SUPER D.O.A.

With seven *Transworld Good Wood Awards* in six years for the D.O.A. series, it's clear that the performance and value of these boards are unmatched. FORTRESS™ KEVLAR BOUND SIDEWALLS are bonded by a Kevlar "S" wrap from the top of the sidewall to the underside of the core. This lightweight technology binds the sidewall and core material together like no other.

CAMBER OVERVIEW

ALPINE PROFILE

ALPINE V1 PROFILE • MEGA DEATH • THE BLACK SNOWBOARD OF DEATH

The *ALPINE V1 Profile* design features mid-body camber with a flat tail and a reverse cambered nose. This allows for tons of pop and stability on hard pack while increasing float and landing power, improving the rider's performance in deep snow. The camber runs longer in the tail—providing extra power for the ascent or for larger riders drawn to a dedicated wide series.

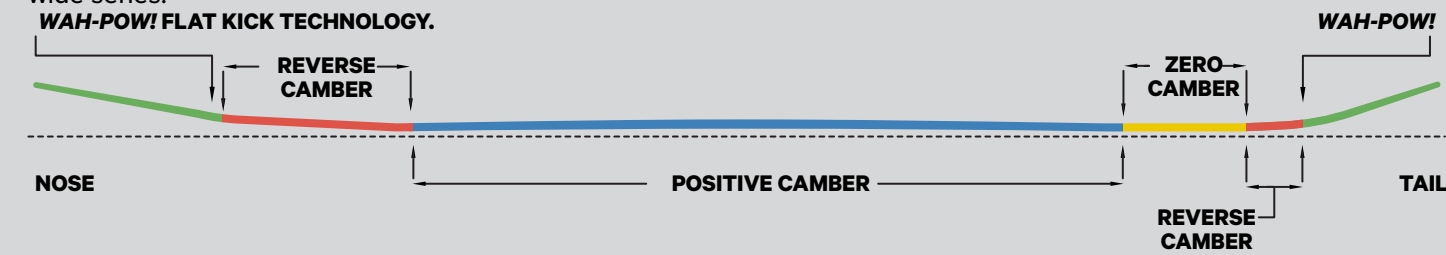

ALPINE V3 PROFILE AERONAUT

The *ALPINE V3 profile* has a deeper traditional camber that zeros out before the end of the sidecut. The small zero camber sections provide a more controlled ride while retaining the response and power of a throwback cambered board.

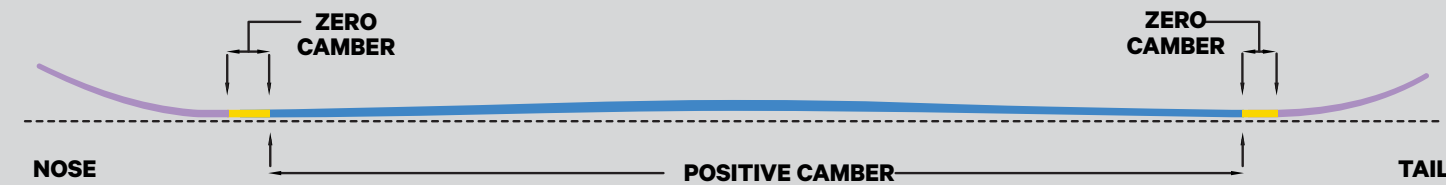

RESORT PROFILE

RESORT V1 PROFILE • SUPER D.O.A. • ULTRA FEAR CAM • D.O.A. • BIRDS OF A FEATHER • CHILDREN OF THE GNAR

Our *RESORT V1 Profile* boards take full advantage of the benefits of traditional camber, zero camber, and reverse camber. This next generation design allows you to get the pop and response of a cambered board with all the predictability and easy turn initiation of zero camber or reverse camber shapes.

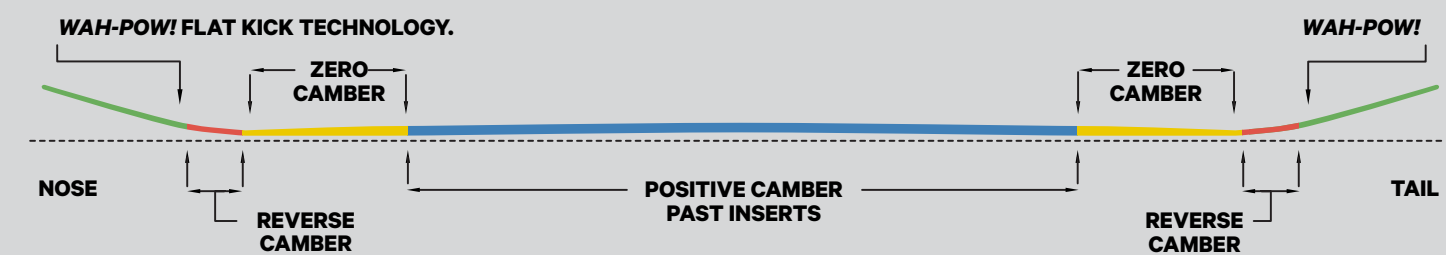

RESORT V2 DIRECTIONAL PROFILE • MEGA SPLIT • MEGA MERC • MERCURY • THE NAVIGATOR • NAVIGATOR SPLIT • THE EQUALIZER

This revolutionary all-terrain shape provides the best of both worlds. It has a raised camber platform through the inserts to retain high-speed edge hold through variable terrain, elevated contact points to land and float in powder, and Flat Kick tip and tail arcs for faster, more aggressive transitions.

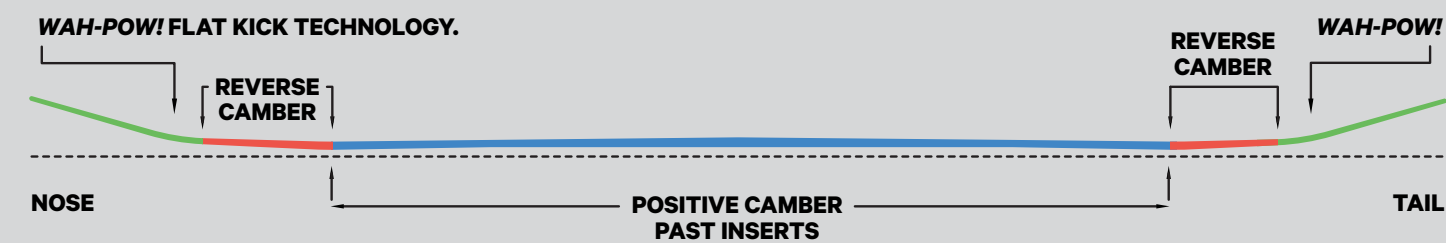

RESORT V2 TWIN PROFILE • SB RESORT TWIN

This revolutionary all-terrain shape provides the best of both worlds. It has a raised camber platform through the inserts to retain high-speed edge hold through variable terrain, elevated contact points to land and float in powder, and Flat Kick tip and tail arcs for faster, more aggressive transitions.

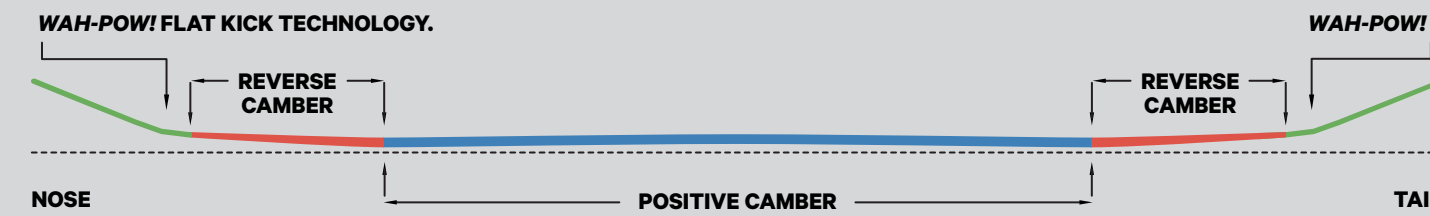

RESORT V3 PROFILE • KAZU KOKUBO PRO • OUTERSPACE LIVING • PARADISE

The *RESORT V3 Profile* maximizes versatility. It has a raised camber platform through the inserts to retain high-speed edge hold through variable terrain, elevated contact points to land and float in powder, and traditional tip and tail arcs for smoother transitions.

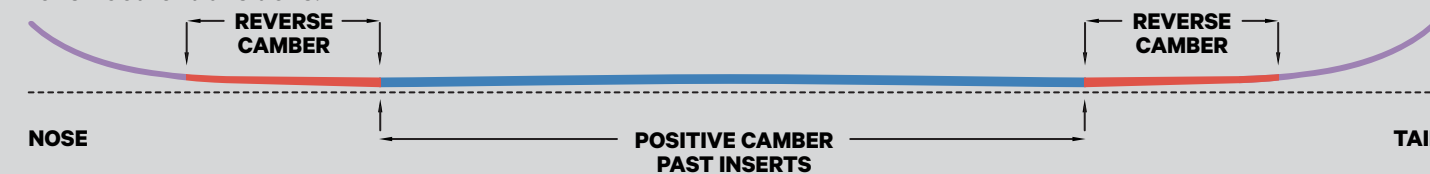

PARK PROFILE

PARK V1 PROFILE • DARK HORSE

The *PARK V1* camber configuration zeros out a traditional camber approach 4 cm before the end of the sidecut. The small zero camber sections provide a more controlled ride while retaining the response and power of a cambered board.

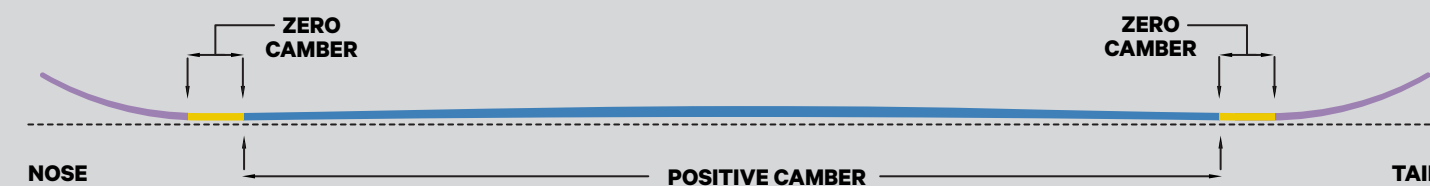

PARK V1 + FLAT KICK TECH PROFILE • INDOOR SURVIVAL • PATHFINDER

The *PARK V1* camber configuration zeros out a traditional camber approach 4 cm before the end of the sidecut transitioning into a Flat Kick nose and tail.

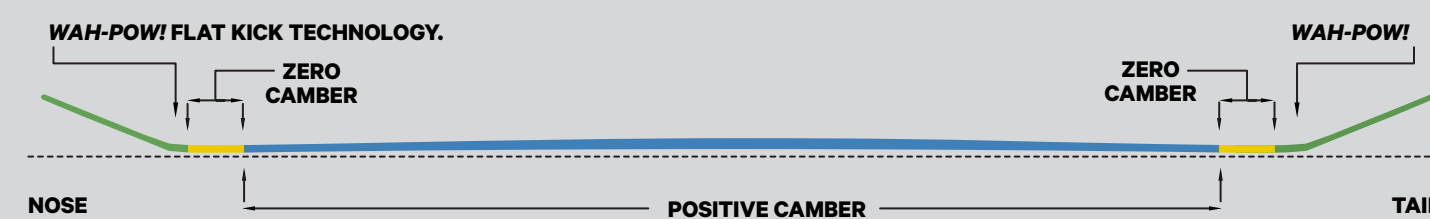

PARK V2 PROFILE • PATHFINDER REV • SPACE METAL FANTASY

These versatile boards feature a dual reverse camber Flat Kick freestyle shape. A zero camber section through the insert area provides a stable skate-style feel, while elevated contact points turn on a dime and float effortlessly in powder.

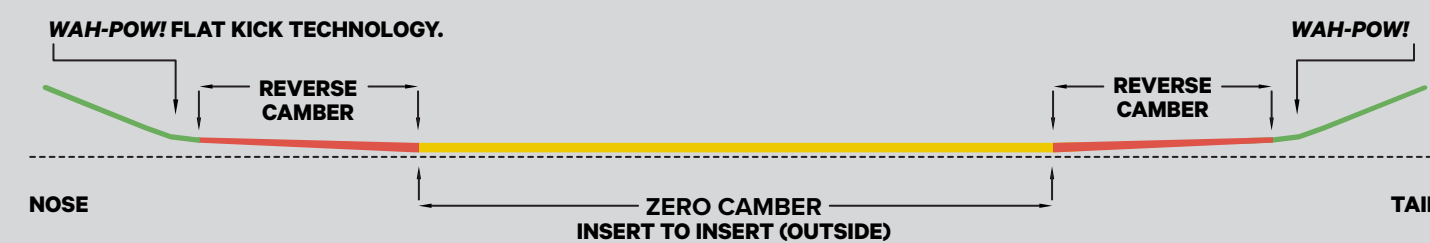

PARK MINI PROFILE • JESS KIMURA MINI • SCOTT STEVENS MINI • MICRO MINI

Rockered and beveled for catch free riding.

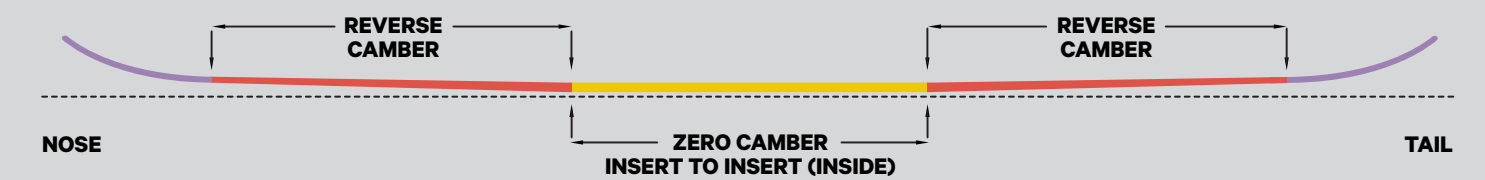

SURF ROCKER PROFILE

SURF ROCKER PROFILE • SB POWDER GLDER

The *SURF ROCKER* features a continuous arching tip and tail inspired by the modern design of many of today's best surfboards: flat through the inserts with smooth arcing tip and tails. The gentle low angle allows for maximum float and control.

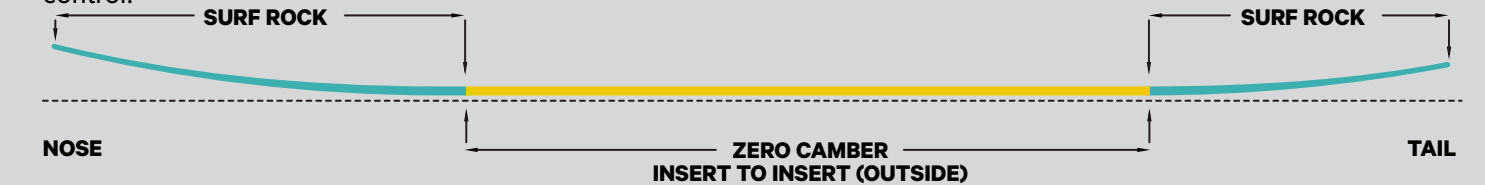

SURF CAMBER PROFILE

SURF CAMBER PROFILE • SB POWDER RACERS • SB SLUSH SLASHERS 2.0

The *SURF CAMBER* features a continuous arching tip and tail inspired by the modern design of many of today's best surfboards: flat through the inserts with smooth arcing tip and tails. The gentle low angle allows for maximum float and control.



SURF CAMBER TWIN PROFILE • SB POWDER TWIN

The *SURF CAMBER TWIN* features a raised camber platform through the inserts to retain a poppy freestyle feel over variable terrain and elevated low-angle contact points to land and float in powder.

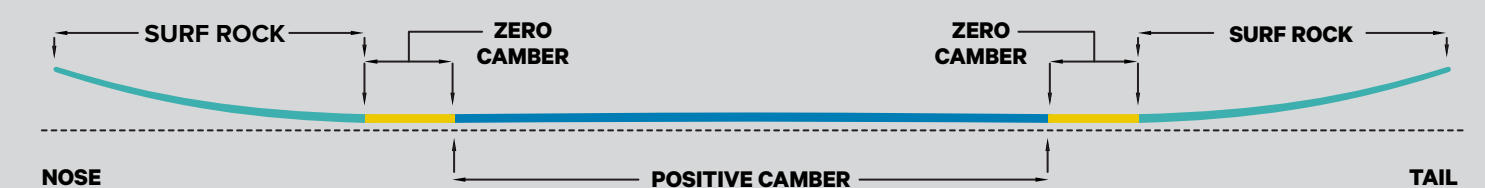

SIDECUT

Sidecut dictates the board's *turning functionality*.



Sidecut is the arcing shape that the outer rails of the board take from the wide points near the nose and tail toward the narrow point in the middle of the board. Sidecut dictates the board's turning functionality along with the personality of a snowboard.

1

- MEGA SPLIT
- MEGA DEATH
- MEGA MERC
- THE BLACK SNOWBOARD OF DEATH
- MERCURY

NEW AGE PROGRESSIVE

Our *NEW AGE PROGRESSIVE* sidecuts are progressive sidecuts that incorporate *DEATH GRIP™*.

2

- INDOOR SURVIVAL
- SB RESORT TWIN

NEW AGE RADIAL

Our *NEW AGE RADIAL* sidecut employs the same arc from contact point to contact point allowing the board to have a true twin tip shape that utilizes *DEATH GRIP™* technology for enhanced control.

3

- AERONAUT

PROGRESSIVE

A *PROGRESSIVE* sidecut consists of two or more radii blended together to accommodate the three stages of a turn. They provide easy turn initiation while offering greater control throughout the turn and maximum power when exiting.

4

- THE OUTSIDERS
- ULTRAFEAR
- OUTERSPACE LIVING
- PARADISE
- PATHFINDER
- SPACE METAL FANTASY
- SB SLUSH SLASHERS 2.0
- JESS KIMURA MINI
- SCOTT STEVENS MINI
- MICRO MINI

RADIAL

A *RADIAL* sidecut is a single radius design that allows your board to start and finish a turn on the same arc.

5

- SUPER D.O.A.
- THE EQUALIZER BY JESS KIMURA
- SB POWDER TWIN
- D.O.A.
- BIRDS OF A FEATHER
- CHILDREN OF THE GNAR

BLENDED RADIAL

BLENDED RADIAL sidecuts feature a single radius arc through the midsection of the board combined with a custom designed blend zone at the contact points. Varying the length of these blend zones and tailoring them specifically for certain aspects of riding greatly improves a board's performance.

6

- SB POWDER GLIDER
- SB POWDER RACERS
- CHILDREN OF THE POW

SURF BLENDED RADIAL

Inspired by a combination of surfboard design and on snow riding functionality, the all new *SURF BLENDED RADIAL* sidecut is the ultimate powder surfing shape. This shape features a radial sidecut just through and past the inserts, followed by a huge smooth reverse blend zone and then topped off with a ton of taper. Surf the earth and get loose in the white room!

7

- KAZU KOKUBO PRO

RADICAL TAPER

Engineered for deep powder but still versatile around the mountain, this *RADIAL* sidecut is complemented by a *TAPERED TAIL*. This narrower tail section naturally sinks in the powder while the wider nose section floats above the snow line. The result is less work and more fun as the board surfs on one smooth continual arc.

8

- THE NAVIGATOR
- THE NAVIGATOR SPLIT

PARABOLIC

A *PARABOLIC* sidecut consists of a mirror-symmetrical curve. In snowboard terms, this design creates a board with a deeper sidecut and a quicker turning point in the center compared to radial arcs.

DEATH GRIP™

DEATH GRIP™ is a design theory that incorporates a reverse sidecut arc in the midsection of the board. This reverse camber arc provides a point of contact to apply pressure and retain control throughout the turn in both freestyle and freeride settings.

- MEGA SPLIT • MEGA DEATH • MEGA MERC • THE BLACK SNOWBOARD OF DEATH • MERCURY • INDOOR SURVIVAL • SB RESORT TWIN

FLAT KICK

With *CAPiTA's FLAT KICK* design technology, we've tightened the tip profile radius that blends the shoulders of the board into the tip and tail height on reverse camber boards. The tight tip radius in conjunction with tuned blend zones allows you to have a forgiving and easy to ride reverse camber board that is still responsive and quick during edge to edge transitions. This also creates a flat tip and tail which increases jibbing stability and also helps the board plane on top of powder creating float and control.

- MEGA DEATH • MEGA MERC • MEGA SPLIT • SUPER D.O.A. • THE BLACK SNOWBOARD OF DEATH • MERCURY • THE NAVIGATOR • THE NAVIGATOR SPLIT • THE EQUALIZER BY JESS KIMURA • INDOOR SURVIVAL • ULTRAFEAR • D.O.A. • BIRDS OF A FEATHER • PATHFINDER • SPACE METAL FANTASY • SB RESORT TWIN • SB SLUSH SLASHERS • CHILDREN OF THE GNAR

FLEX RATINGS

1



10

Technology integrated into snowboard construction affects many characteristics of a board's performance. Flex, along with weight, stability, energy and other factors come into play when considering whether a board is right for you. Flex may be the most important as it will determine how you are able to manipulate your board on snow. Soft, flexible boards are great for jibbing and overall command over your snowboard, especially in the park. They're easy to ride and very forgiving. Stiffer boards have more pop, more energy, and more stability at high speeds but they require more effort and skill from the rider as well.

All boards in this catalog are rated on a scale from 1 to 10. The number given is the estimated resistance the board may provide to the average customer.

1 would be the resistance of a noodle, 10 would be the resistance of a tree trunk.

BLEND ZONES

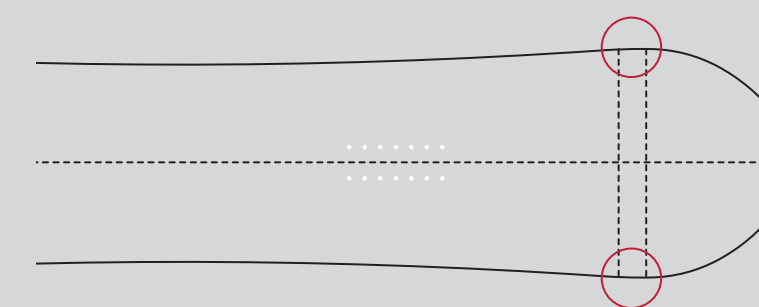

All snowboard shapes are designed with four blend zones. This is the area after the sidecut ends and before the nose or tail shape starts. In this small section, the shape of the board must transition from a sidecut arc going one direction into the tip shape arc going in the opposite direction. This critical section of the board is similar to the steering system in your car. It's the driving force in initiating turns and determining where your board is going. A poorly designed blend zone will cause your board to be hooky or turn slowly and could limit your ability to transition between edges. *CAPiTA* has taken the time to pay distinct attention to this detail; fine-tuning each and every board

PRINTING TECH

At CAPiTA, not only do we strive to make the most *Totally Incredible Technical Snowboards™* in the world, we think it's important that they look beautiful too.

The fact is, getting snowboards to look AMAZING is hard. The technical requirements for bonding and durability in extreme climatic and physical conditions severely limits options, and these challenges keep most companies confined to standard methods. The result is often a lifeless, soulless, reproduction that fails to explore the particular possibilities of each graphic. Through rigorous testing, wild experimentation and hard-earned experience, our mad art scientists have developed new techniques that maximize each graphic's unique potential. Our mission is to completely surpass what was once technically impossible.



1 DEEPSPACE™ DESIGN THEORY

You don't like shallow humans, so why would you like shallow topsheets? The *DEEPSPACE™ Design Theory* takes advantage of the thickness of a transparent topsheet. Strategically layering ink on multiple levels from the top and the bottom we are able to imbue our graphics with a sense of life through depth.

Simple in theory, it requires an expert knowledge of ink bonding characteristics and curing times to make production efficient and technically feasible.

It's also expensive as hell, and considered to be cost prohibitive for many of our competitors.

2 PAM16000™ PRINTING

All 2024 boards utilizes PAM16000™ except:

- MEGA SPLIT
- MEGA DEATH

Our mad art scientists at *The MotherShip* needed more power. And at CAPiTA where *Everything Is Possible™*, ask and ye shall receive.

PAM is now *TWICE* as powerful. She can make *TWICE* as much art. And she is *TWICE* the machine as she was last year. Spec'd out to the max with a mind-boggling *SIXTEEN THOUSAND* ink jet nozzles, *PAM16000™* makes our knees weak, and our hearts palpitate.

She can now spit out solventless, water based UV inks at twice the speed, with the same deadly accuracy and quality.

DEEPSPACE™ AT WARPSPEED. The future is now.

3 SILKSCREEN

All 2024 boards!

ROCK POSTERS. The best ones are screen-printed, framed and enviously eyed by bros at the man cave. They are awesome because they're handmade with love, and so are our silkscreened top sheets. Unbeknownst to most people, the *CAPiTA MFG* print shop is staffed by a merry band of tough as nails Austrian mothers who enjoy tea and apfelstrudel after work. Next time you notice how the colors pop like crazy on your topsheet, thank these ladies as each topsheet is like a hand-knitted sweater from Mom.

4 DIE-CUT

- MEGA SPLIT
- MEGA DEATH
- MEGA MERC
- SUPER D.O.A.
- THE BLACK SNOWBOARD OF DEATH
- AERONAUT
- MERCURY
- NAVIGATOR SPLIT
- THE NAVIGATOR
- CHILDREN OF THE GNAR
- JESS KIMURA MINI
- MICRO MINI
- SB POWDER GLIDER

Super precise laser-guided, die cutting technology enable sharp edges and poppy AF solid color for our bases. It's an Herculean feat to assemble all the little pieces back together again but *gaaaddamn* it looks fine.

6 SUBLIMATION

- THE BLACK SNOWBOARD OF DEATH
- KAZU KOKUBO PRO
- MERCURY
- THE EQUALIZER BY JESS KIMURA
- THE OUTSIDERS
- INDOOR SURVIVAL
- ULTRAFEAR
- PATHFINDER
- SPACE METAL FANTASY
- D.O.A.
- BIRDS OF A FEATHER
- CHILDREN OF THE POW
- CHILDREN OF THE GNAR
- SB SLUSH SLASHERS

Sublimation is an exact science for an inexact process. In sublimation, ink is pushed through a substrate into base material using pressure and heat.

As base material is thicker and more opaque than topsheets, graphics become more vibrant when ink impregnates the material as opposed to other techniques where the ink is applied to one side or the other. Through sublimation, ink sits closer to the sliding surface and this technique excels when full colors are required. Many long nights were spent tinkering with a complex combination of cook-times, pressure and temperature in a highly controlled environment to achieve some of *CAPiTA's* signature base graphics.

7 MULTITECH™

All 2024 boards utilizes MULTITECH™ except:

- CHILDREN OF THE POW
- CHILDREN OF THE GNAR
- JESS KIMURA MINI
- SCOTT STEVENS MINI
- MICRO MINI

Voltron was awesome because it was one robot made up of a bunch of other robots. Sometimes if we find utilizing a single technique just isn't enough, we open up the armory and stack one process on top of another!

Whether it's a *PAM16000™* printed topsheet with silkscreen embellishments, or a sublimated base with silkscreen and die-cut pieces, *MULTITECH™* sends you further into *DEEPSPACE™*.

8 PLT TOPSHEET TECHNOLOGY™

All 2024 boards utilizes PLT except:

- MEGA SPLIT
- MEGA MERC
- MEGA DEATH
- NAVIGATOR SPLIT
- SUPER D.O.A.
- THE BLACK SNOWBOARD OF DEATH
- KAZU KOKUBO
- SB SLUSH SLASHERS 2.0
- PATHFINDER
- CHILDREN OF THE POW
- CHILDREN OF THE GNAR
- JESS KIMURA MINI
- SCOTT STEVENS MINI
- MICRO MINI

The *PLT™* machine sits in a secret hidden corner of the factory behind two very unassuming, nondescript metal doors. The *PLT™* is so secretive that all visitors to the room must be versed in an ever-changing secret handshake.

PLT™ technology is exclusive to *CAPiTA MFG* and magically bonds the topsheet to an already pressed snowboard.

This is magical because the rest of the world mashes their topsheets on with glue, heat and pressure during the pressing stage. Doing so causes the fiberglass structure underneath to show through the topsheet. And because nobody wants to spend their hard earned cash on a bumpy snowboard, many companies slather their tops with a thick toxic lacquer to smooth things out. Not only is that shit *HEAVY* and can potentially develop unsightly hairline cracks, it's also really unhealthy for the working environment.

The *PLT™* machine produces a featherlight, smooth, high-gloss finish, without all that poisonous deadweight.

SCIENCE IS MAGIC, WAAAAHBAH!!

Tech Overview

	BOARD PERSONALITY	CAMBER STYLE	SIDECUT STYLE	STANCE SET BACK	CORE TYPE	FIBERGLASS / RESIN	ADDITIVES	BASE	
RESORT	NEW! SUPER D.O.A.	THE ULTIMATE SNOWBOARD—SUPER-CHARGED	RESORT V1 PROFILE	BLENDED RADIAL—TRUE TWIN	CENTERED	NEW! 3D THERMOPOLYMER STARSHIP CORE™	HYBRID CARBON HOLYSHEET™ TRI/TRI FIBERGLASS MAGIC BEAN RESIN	3D PROFILING + 2 x INTERGRATED SUPER CARBON™ + FORTRESS™ ARAMID BOUND SIDEWALLS	HYPERDRIVE™ ADV XT + MOONSHOT OMNI-TUNE™
	AERONAUT	ROCKETMAN AIRTIME!	ALPINE V3 PROFILE	PROGRESSIVE—DIRECTIONAL	0.8 INCH	P2 SUPERLIGHT™	HOLYSHEET™ TRI/TRI FIBERGLASS MAGIC BEAN RESIN	4 x CARBONFLAX™ V-TECH AMPLIFIERS + 4 x BAMBOO POWER RODS	HYPERDRIVE™ ADV™ XT
	D.O.A.	THE ULTIMATE SNOWBOARD	RESORT V1 PROFILE	BLENDED RADIAL—TRUE TWIN	CENTERED	P2 SUPERLIGHT™	HYBRID CARBON HOLYSHEET™ BI/BI FIBERGLASS MAGIC BEAN RESIN	2 x INTERGRATED CARBON FIBER BEAMS	QUANTUM DRIVE™
	BIRDS OF A FEATHER	WOMEN'S VERSION OF THE ULTIMATE SNOWBOARD	RESORT V1 PROFILE	BLENDED RADIAL—TRUE TWIN	CENTERED	P2 SUPERLIGHT™	HYBRID CARBON HOLYSHEET™ BI/BI FIBERGLASS MAGIC BEAN RESIN	2 x INTERGRATED CARBON FIBER BEAMS	QUANTUM DRIVE™
	OUTERSPACE LIVING	MULTITOOL VERSATILITY	RESORT V3 PROFILE	RADIAL—DIRECTIONAL TWIN	0.5 INCH	MULTIZONE DUAL CORE™	SPECIAL BLEND™ FIBERGLASS / MAGIC BEAN RESIN	NEW! 4 x CARBON BOOSTERS	SUPERDRIVE™ ADV
	PARADISE	WOMEN'S—SMOOTH AND PREDICTABLE MULTITOOL	RESORT V3 PROFILE	RADIAL—DIRECTIONAL TWIN	0.5 INCH	MULTIZONE DUAL CORE™	SPECIAL BLEND™ FIBERGLASS / MAGIC BEAN RESIN	NEW! 4 x CARBON BOOSTERS	SUPERDRIVE™ ADV
FREESTYLE	INDOOR SURVIVAL	INTERDIMENSIONAL HOT LAP MACHINE	PARK V1 + FLAT KICK TECH PROFILE	NEW AGE RADIAL + DEATH GRIP™—TRUE TWIN	CENTERED	META CORE™	HOLYSHEET™ TRI/BI FIBERGLASS MAGIC BEAN RESIN	TITANAL CENTERLINE BOOSTER	QUANTUM DRIVE™
	NEW! ULTRAFEAR	THE RESORT AND PARK DESTROYER	RESORT V1 PROFILE	RADIAL—TRUE TWIN	CENTERED	P2 SUPERLIGHT CORE™	NEW! HYBRID CARBON HOLYSHEET™ BI/BI FIBERGLASS MAGIC BEAN RESIN	1.5 mm CORK DAMPENING SYSTEM	SUPERDRIVE™ ADV
	NEW! DARK HORSE	TRANSITION, PARK, AND RESORT VEHICLE	PARK V1 PROFILE	RADIAL—TRUE TWIN	CENTERED	HOVER CORE™	SPECIAL BLEND™ FIBERGLASS / MAGIC BEAN RESIN	2 x CARBON ARAMID BOOSTERS	HYPERDRIVE™
	PATHFINDER	LEGENDARY JIB MACHINE	PARK V2 PROFILE	RADIAL—TRUE TWIN	CENTERED	DUAL CORE™	SPECIAL BLEND™ FIBERGLASS / MAGIC BEAN RESIN	—	SUPERDRIVE™
	SPACE METAL FANTASY	WOMEN'S—EFFORTLESS RIDE THROUGH THE PARK OR POW	PARK V2 PROFILE	RADIAL—TRUE TWIN	CENTERED	DUAL CORE™	SPECIAL BLEND™ FIBERGLASS / MAGIC BEAN RESIN	—	SUPERDRIVE™
FREERIDE	MEGA DEATH	THIS BOARD RIPS THE WHOLE MOUNTAIN, AND YOU WILL TOO	ALPINE V1 PROFILE	NEW AGE PROGRESSIVE + DEATH GRIP™—DIRECTIONAL	0.8 INCH	THERMOPOLYMER STARSHIP CORE™	PURE MEGACARBON™	PURE MEGACARBON™	MEGADRIVE™ XT + MOONSHOT OMNI-TUNE™
	MEGA MERC	A FREERIDE MACHINE OF EPIC PROPORTIONS	RESORT V2 DIRECTIONAL PROFILE	NEW AGE PROGRESSIVE + DEATH GRIP™—DIRECTIONAL	0.5 INCH	3D THERMOPOLYMER STARSHIP CORE™	HYBRID CARBON HOLYSHEET™ TRI/TRI FIBERGLASS MAGIC BEAN RESIN	3D PROFILING + INTERGRATED MEGACARBON™ ARRAY	MEGADRIVE™ XT + MOONSHOT OMNI-TUNE™
	BLACK SNOWBOARD OF DEATH	THIS BOARD RIPS THE WHOLE MOUNTAIN, AND YOU WILL TOO	ALPINE V1 PROFILE	NEW AGE PROGRESSIVE + DEATH GRIP™—DIRECTIONAL	0.8 INCH	THERMOPOLYMER HOVER CORE™	HOLYSHEET™ TRI/TRI FIBERGLASS MAGIC BEAN RESIN	2 x CARBON FLEECE POWER SHIELD™ + 4 x AMPLITEX™ V-TECH AMPLIFIERS	HYPERDRIVE™ ADV XT + MOONSHOT OMNI-TUNE™
	KAZU KOKUBO PRO	WHERE FREESTYLE MEETS POWDER	RESORT V3 PROFILE	RADICAL TAPER—DIRECTIONAL	0.8 INCH	PANDA HOVER CORE™	HOLYSHEET™ TRI/BI FIBERGLASS MAGIC BEAN RESIN	SKINLESS™ LIGHTWEIGHT TOPSHEET + 4 x CARBONFLAX™ V-TECH AMPLIFIERS + 4 x BAMBOO POWER RODS	HYPERDRIVE™ ADV XT+ MOONSHOT OMNI-TUNE™
	MERCURY	ANY TIME, ANY PLACE, FREERIDE MACHINE	RESORT V2 DIRECTIONAL PROFILE	NEW AGE PROGRESSIVE + DEATH GRIP™—DIRECTIONAL	0.5 INCH	HOVER CORE™	HOLYSHEET™ TRI/BI FIBERGLASS MAGIC BEAN RESIN	4 x CARBONFLAX™ V-TECH AMPLIFIERS	HYPERDRIVE™
	THE NAVIGATOR	SIDECOUNTRY RESORT POWDER MACHINE	RESORT V2 DIRECTIONAL PROFILE	PARABOLIC RADICAL TAPER—DIRECTIONAL	0.8 INCH	HOVER CORE™	HOLYSHEET™ TRI/BI FIBERGLASS MAGIC BEAN RESIN	2 x TIP TO TAIL TECHNORA™ FLAX BOOSTERS	HYPERDRIVE™
	THE EQUALIZER	ON THIS BOARD, YOU COULD BE RIDER OF THE YEAR	RESORT V2 DIRECTIONAL PROFILE	BLENDED RADIAL—DIRECTIONAL	0.8 INCH	META CORE™	HOLYSHEET™ TRI/BI FIBERGLASS MAGIC BEAN RESIN	2 x TECHNORA™ FLAX BOOSTERS	QUANTUM DRIVE™

	<i>BOARD PERSONALITY</i>	<i>CAMBER STYLE</i>	<i>SIDECUT STYLE</i>	<i>STANCE SET BACK</i>	<i>CORE TYPE</i>	<i>FIBERGLASS / RESIN</i>	<i>ADDITIVES</i>	<i>BASE</i>	
YOUTH	CHILDREN OF THE POW	POWDER SPECIFIC RIPPER FOR THE UP AND COMERS	SURF ROCKER	BLENDED RADIAL—DIRECTIONAL	0.8 INCH	MULTIZONE SELECT CORE 2.0	SPECIAL BLEND™ FIBERGLASS / MAGIC BEAN RESIN	—	XXX[TRUDED]™
	CHILDREN OF THE GNAR	RIDES LIKE A MINI DOA	RESORT V1 PROFILE	BLENDED RADIAL—TRUE TWIN	CENTERED	SELECT CORE 2.0	SPECIAL BLEND™ FIBERGLASS / MAGIC BEAN RESIN	—	XXX[TRUDED]™
	JESS KIMURA MINI	CATCH FREE CONFIDENCE IN THE EARLY YEARS	PARK MINI PROFILE	RADIAL—TRUE TWIN	CENTERED	SELECT CORE 2.0	BIAX MICRO GLASS / MAGIC BEAN RESIN	—	XXX[TRUDED]™
	SCOTT STEVENS MINI	CATCH FREE CONFIDENCE IN THE EARLY YEARS	PARK MINI PROFILE	RADIAL—TRUE TWIN	CENTERED	SELECT CORE 2.0	BIAX MICRO GLASS / MAGIC BEAN RESIN	—	XXX[TRUDED]™
	MICRO MINI	A PERFECT BOARD FOR EARLY BIRDS.	PARK MINI PROFILE	RADIAL—TRUE TWIN	CENTERED	SELECT CORE 2.0	BIAX MICRO GLASS / MAGIC BEAN RESIN	—	XXX[TRUDED]™
SPLIT	MEGA SPLIT	ULTIMATE LIGHTWEIGHT SPLIT MACHINE	RESORT V2 DIRECTIONAL PROFILE	NEW AGE PROGRESSIVE—DIRECTIONAL	0.5 INCH	3D ASCEND 1 SPLIT CORE™	PURE MEGACARBON™	PURE MEGACARBON™	MEGADRIVE™ + MOONSHOT OMNI-TUNE™
	NAVIGATOR SPLIT	PROVEN POWDER RIPPER	RESORT V2 DIRECTIONAL PROFILE	PARABOLIC RADICAL TAPER—DIRECTIONAL	0.8 INCH	3D ASCEND 2 SPLIT CORE™	HOLYSHEET™ FIBERGLASS TRI/TRI MAGIC BEAN RESIN	2 x AMPLITEX™ AMPLIFIERS—NOSE + DURATAIL™ DIE CUT TOPSHEET	HYPERDRIVE™
SPRING BREAK	POWDER GLIDER	ARTISANAL POWDER SHAPES	SURF ROCKER PROFILE	SURF BLENDED RADIAL—DIRECTIONAL	0.8 INCH	SURFLITE 4.0 CORE™	HOLYSHEET™ TRI/TRI FIBERGLASS MAGIC BEAN RESIN	2 x CARBON FLEECE POWER SHIELD™ + WATERJET CUT ABS1000 SIDEWALLS	POWDER DRIVE™
	POWDER RACERS	POWDER CARVING SURF MACHINE	SURF CAMBER PROFILE	SURF BLENDED RADIAL—DIRECTIONAL	0.5 INCH	HOVER CORE™	HOLYSHEET™ TRI/BI FIBERGLASS MAGIC BEAN RESIN	2 x TECHNORA™ FLAX WIDE BOOSTERS	POWDER DRIVE™
	POWDER TWIN	TRUE TWIN POWDER SLAYER	SURF ROCKER TWIN PROFILE	BLENDED RADIAL—TRUE TWIN	CENTERED	META CORE™	HOLYSHEET™ TRI/BI FIBERGLASS MAGIC BEAN RESIN	4 x CARBON V-TECH AMPLIFIERS	POWDER DRIVE™
	RESORT TWIN	TRUE TWIN RESORT SLAYER	RESORT V2 TWIN PROFILE	NEW AGE RADIAL + DEATH GRIP™—TRUE TWIN	CENTERED	META CORE™	HOLYSHEET™ TRI/BI FIBERGLASS MAGIC BEAN RESIN	4 x CARBON V-TECH AMPLIFIERS	POWDER DRIVE™
	NEW! STAIRMASTER	WALLET FRIENDLY PARK AND RESORT	PARK V1 PROFILE	RADIAL—TRUE TWIN	CENTERED	DUAL CORE™	SPECIAL BLEND™ FIBERGLASS / MAGIC BEAN RESIN	4 x CARBON ARAMID BOOSTERS	SUPERDRIVE™ ADV
	SLUSH SLASHERS	SLUSH AND POWDER SLASHER	SURF CAMBER PROFILE	RADIAL—DIRECTIONAL	0.5 INCH	DUAL CORE™	SPECIAL BLEND™ FIBERGLASS / MAGIC BEAN RESIN	ALLOY SKID PLATE	SUPERDRIVE™
RENTAL	R-SERIES	NO FRILLS, EASY SHRED	PARK V2 PROFILE	RADIAL—TRUE TWIN	CENTERED	DUAL CORE™	SPECIAL BLEND™ FIBERGLASS / MAGIC BEAN RESIN	—	SUPERDRIVE™

SPLIT



MEGA SPLIT



NAVIGATOR SPLIT

POWDER



SB POWDER GLIDER



SB POWDER RACERS



SB POWDER TWIN



CHILDREN OF THE POW



THE NAVIGATOR



SB SLUSH SLASHER



KAZU KOKUBO PRO



THE EQUALIZER BY JESS KIMURA

FREERIDE



MEGA MERC



MERCURY



PARADISE



OUTERSPACE LIVING



MEGA DEATH



THE BLACK SNOWBOARD OF DEATH

RESORT



BIRDS OF A FEATHER



D.O.A.



ULTRAFEAR



SB RESORT TWIN



SB STARMASTER



CHILDREN OF THE GNAR



SUPER D.O.A.



AERONAUT



INDOOR SURVIVAL



MICRO MINI

FREESTYLE

PARK



JESS KIMURA MINI



SCOTT STEVENS MINI



DARK HORSE



SPACE METAL FANTASY



PATHFINDER

JIBBING

BADDEST ASS!!!

BADDER ASS!!

BAD ASS!

CAPiTA

The MotherShip™

HANDCRAFTED WITH 100% CLEAN ENERGY.

The MotherShip™ CONNECTION

The pinnacle of innovation and technology from The MotherShip™.

MEGA DEATH

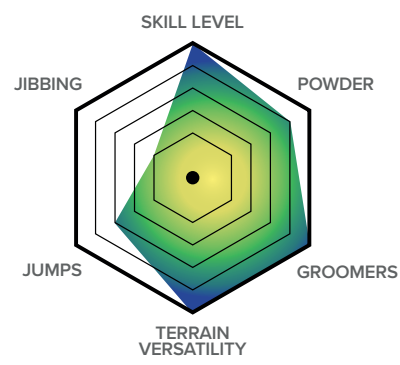

• TECH



156 159 162 157 W 161 W 165 W 169 W **NEW!** BASE

MEGA MERC

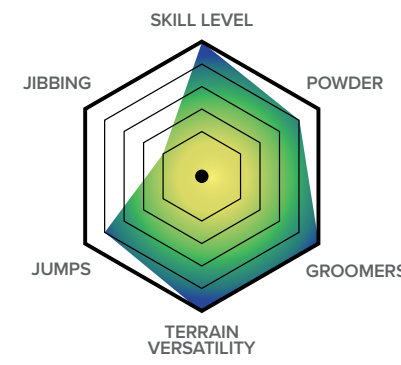

• TECH



153 155 157 159 161 156 W 158 W 160 W BASE

MEGA SPLIT

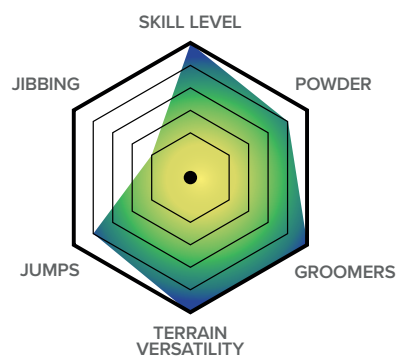

• TECH



155 157 159 161 BASE

SUPER D.O.A. ALL NEW 3D SHAPES!

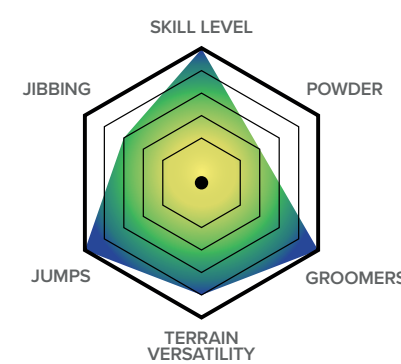

• TECH



152 154 156 158 160 155 W 157 W 159 W 161 W 163 W BASE

RESORT

Engineered for resort riding and all the variables that come with it.

SUPER D.O.A. ALL NEW 3D SHAPES!

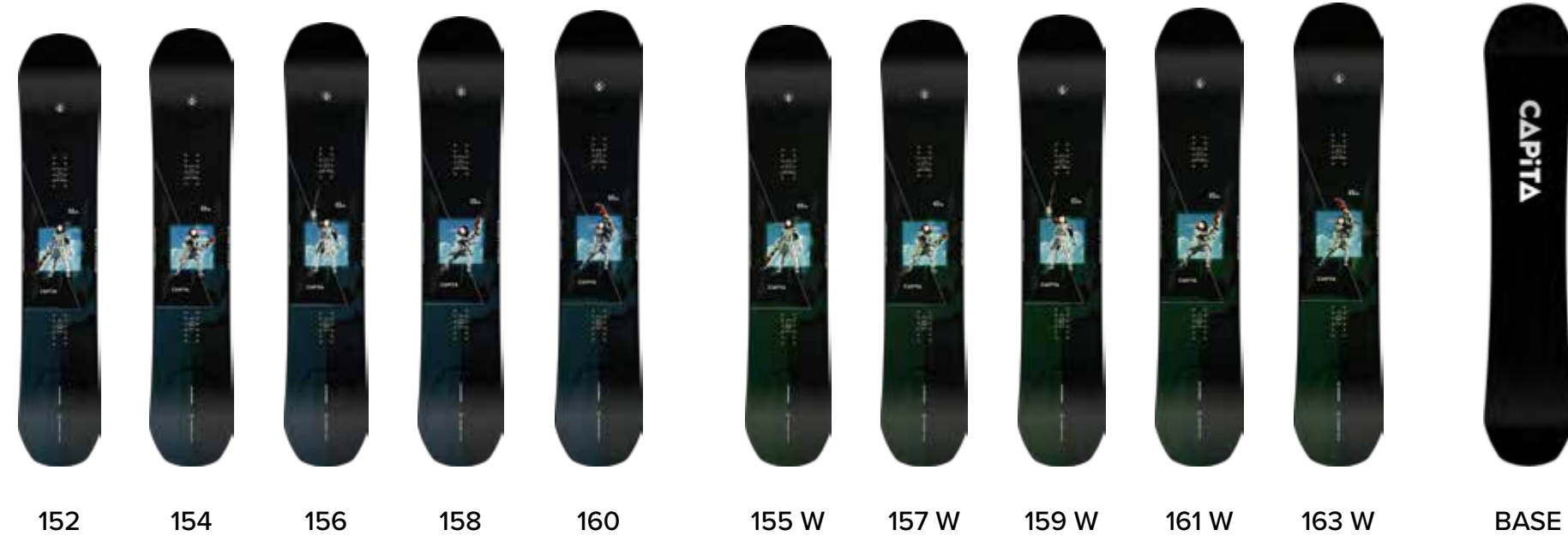
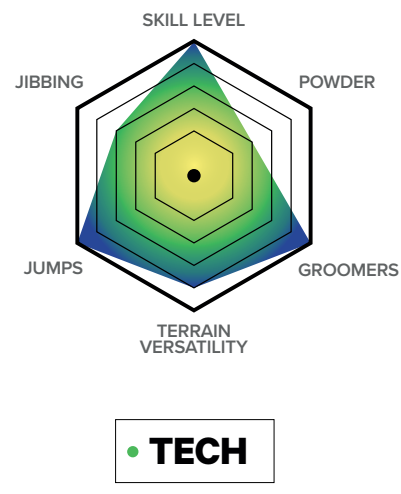

AERONAUT

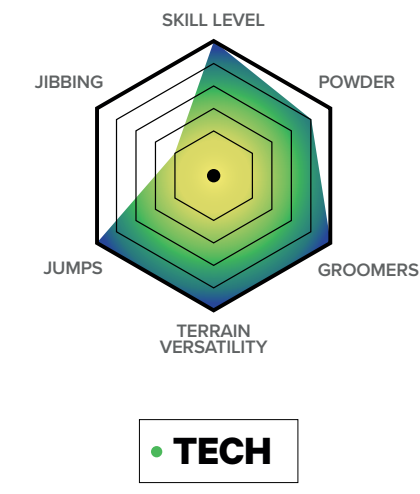

D.O.A.

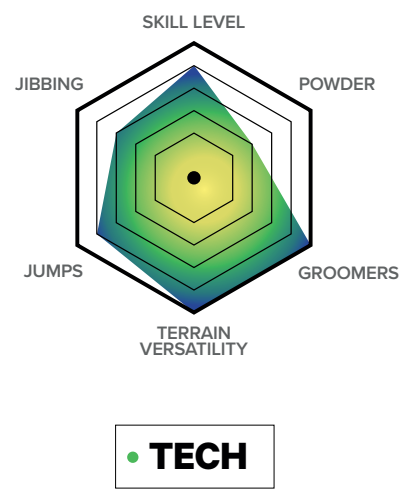

D.O.A. WIDE



BIRDS OF A FEATHER

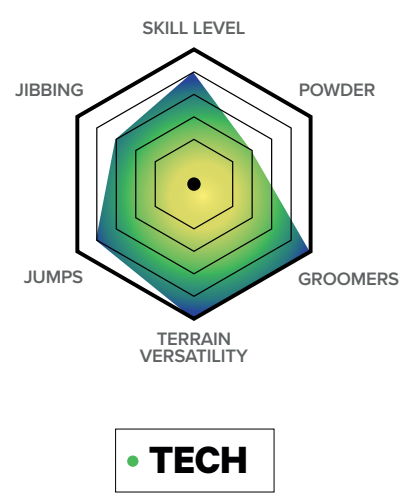

OUTERSPACE LIVING

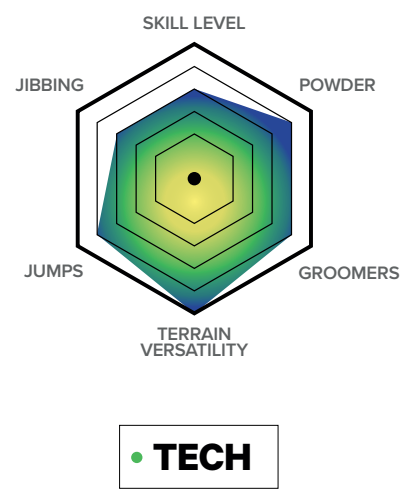

PARADISE

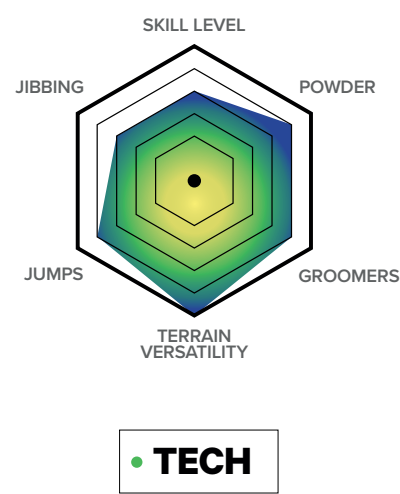

FREESTYLE

Engineered for transitions, rails, and parks.

INDOOR SURVIVAL

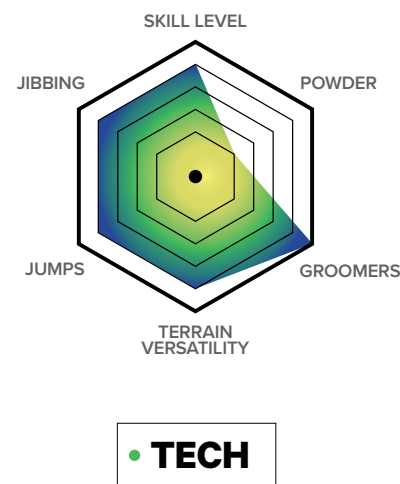

150 152 154 156 158 160 155 W 158 W 161 W BASE

ULTRAFEAR *RESHAPED!*

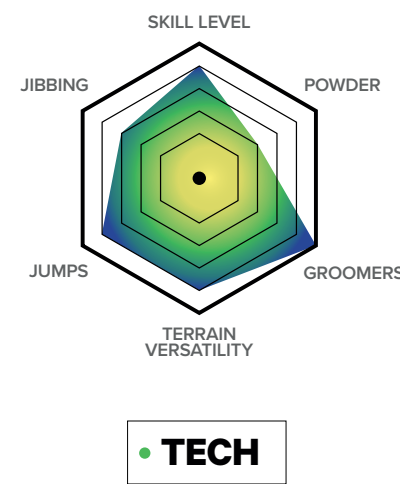

149 151 153 155 157 152 W 155 W 157 W BASE

DARK HORSE *NEW SERIES!*

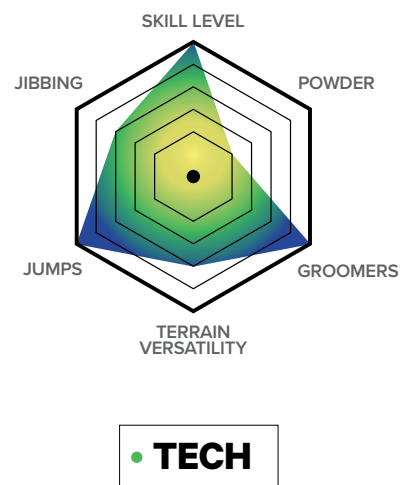

148 150 152 154 156 158 152 W 154 W 156 W 158 W 160 W BASE

PATHFINDER

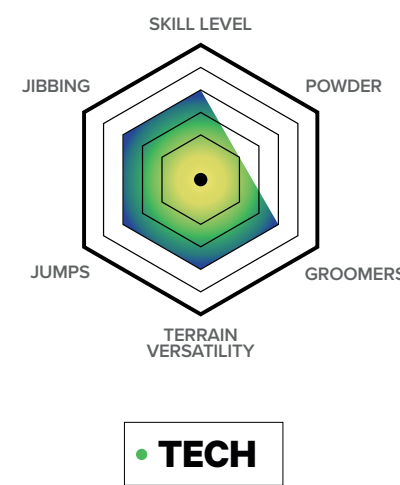

145 147 149 151 153 155 157 151 W 153 W 155 W 157 W 159 W 162 W BASE

SPACE METAL FANTASY

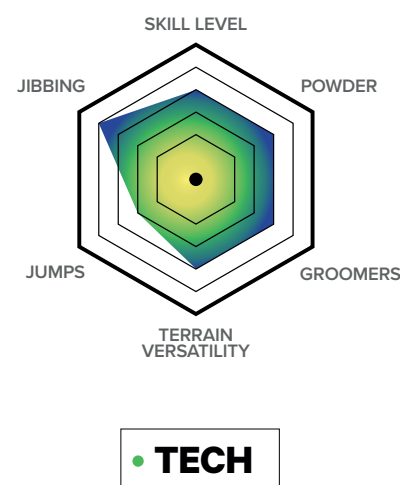

139 141 143 145 147 149 151 153 145 W 149 W 153 W BASE

FREERIDE

Engineered to float in powder and thrive in the mountains.

MEGA DEATH

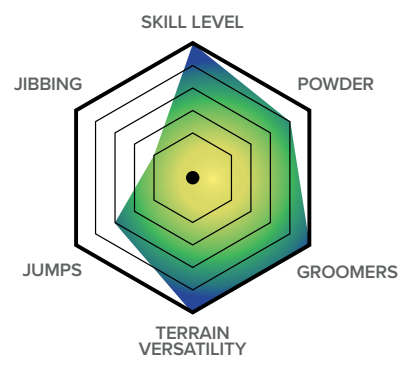

• TECH



156 159 162 157 W 161 W 165 W 169 W **NEW!** BASE

MEGA MERC

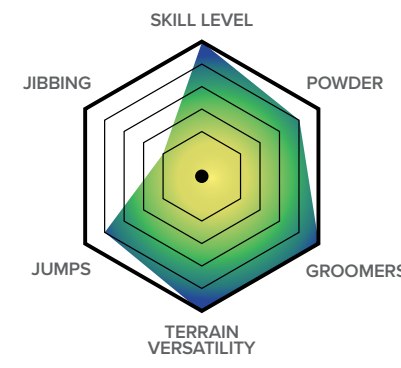

• TECH



153 155 157 159 161 156 W 158 W 160 W BASE

MEGA SPLIT

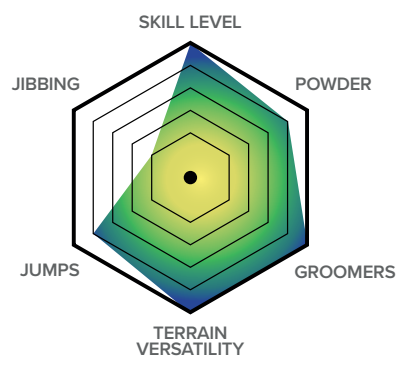

• TECH



155 157 159 161 BASE

THE BLACK SNOWBOARD OF DEATH

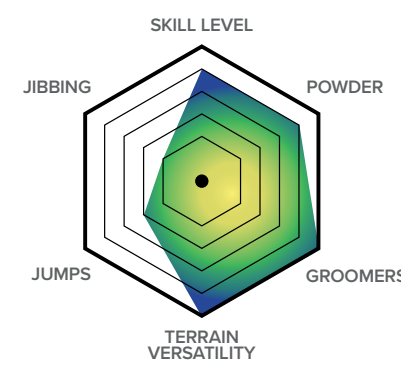

• TECH



156 162 157 W 161 W 165 W 169 W SWAPPED BASE

KEVIN JONES 159



159 SWAPPED BASE

KAZU KOKUBO PRO

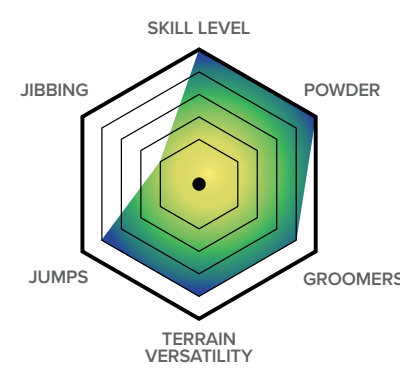

• TECH



151 154 157 160 BASE 155 W 158 W 161 W BASE

MERCURY

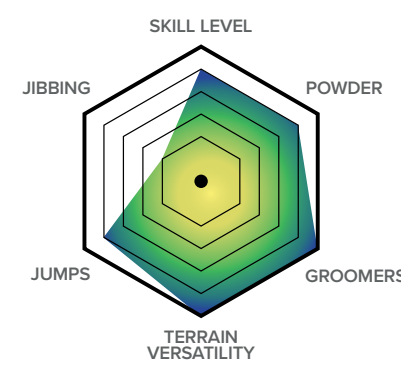

• TECH



147 150 153 155 157 159 161 156 W 158 W 160 W 162 W **NEW!** SWAPPED BASE

THE NAVIGATOR WMN

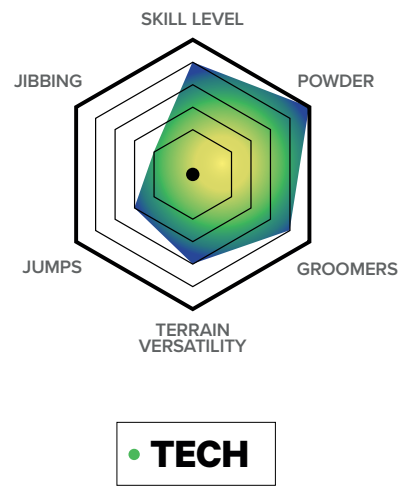

THE NAVIGATOR

NAVIGATOR WMN SPLIT

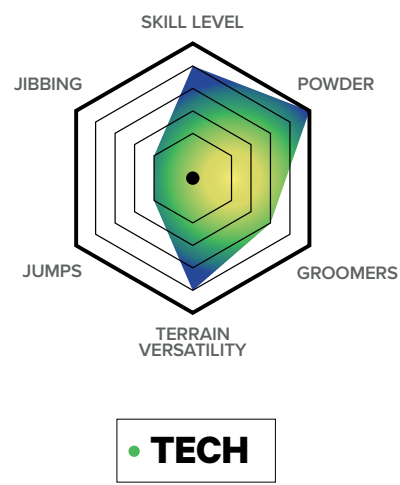

NAVIGATOR SPLIT

THE EQUALIZER BY JESS KIMURA

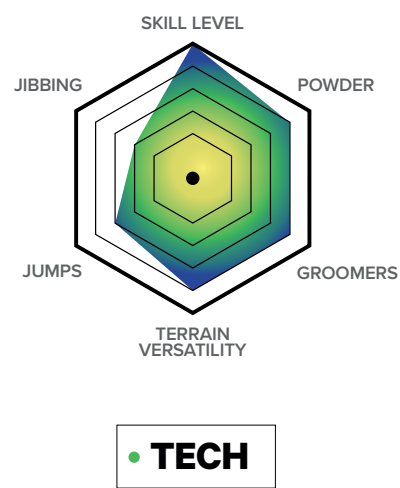

CHILDREN OF THE POW

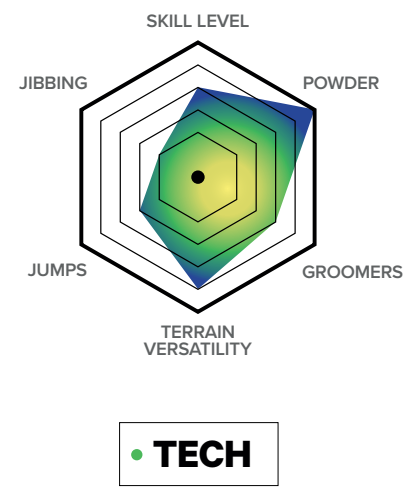

130 135 140

CHILDREN OF THE GNAR

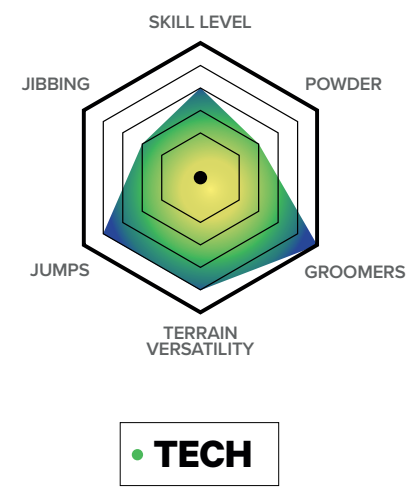

137 141 145 149

JESS KIMURA MINI

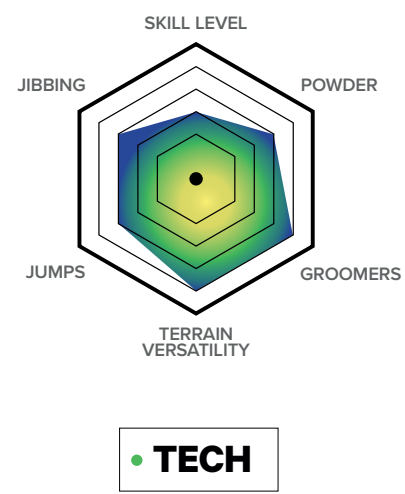

115 120 125 130 135 SWAPPED BASE

SCOTT STEVENS MINI

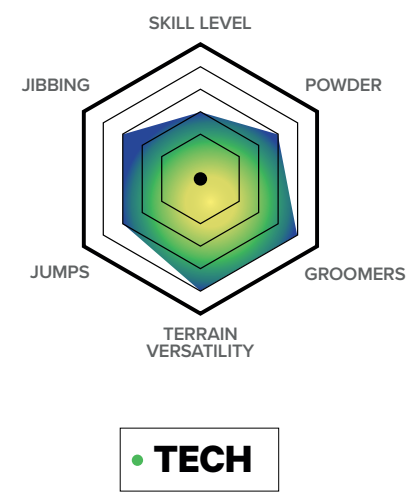

115 120 125 130 135

MICRO MINI

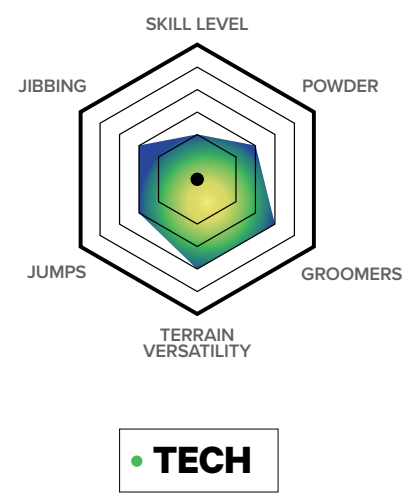

80 90 100 110 SWAPPED BASE

SPRING BREAK

Engineered for Deep Paradise™.

SB POWDER GLIDER

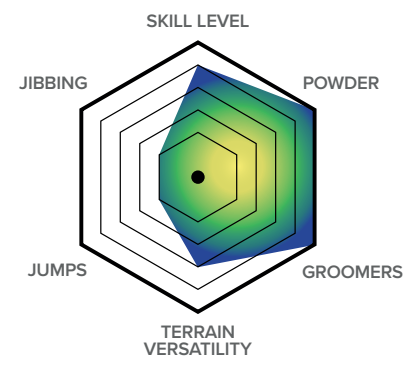

• TECH



154 158 162 SWAPPED BASE

SB POWDER RACERS

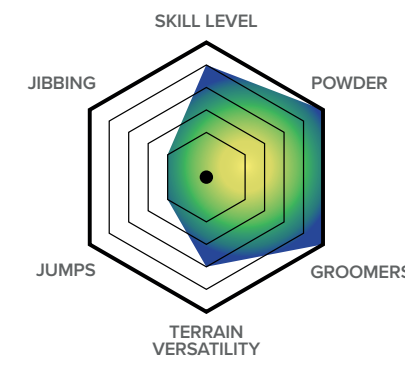

• TECH



149 151 154 157 SWAPPED BASE

SB POWDER TWIN

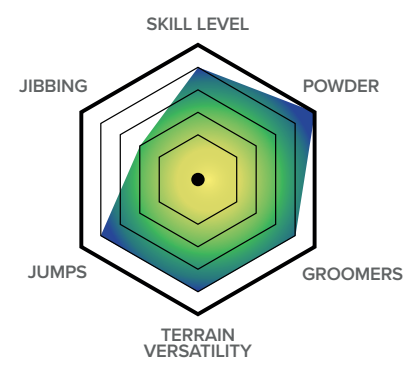

• TECH



153 156 159 162 BASE

SB RESORT TWIN

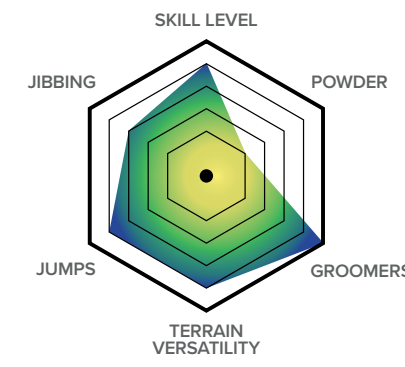

• TECH



152 154 156 158 160 155 W 158 W BASE

SB STAIRMASTER *NEW SERIES!*

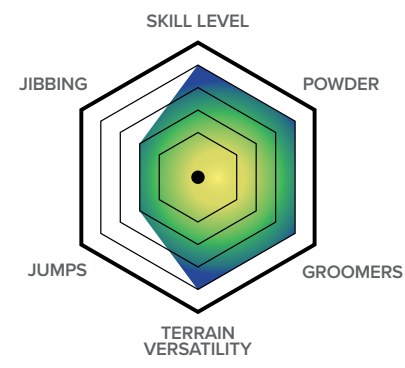

• TECH



152 154 156 158 BASE 156 W 158 W BASE

SB SLUSH SLASHERS 2.0

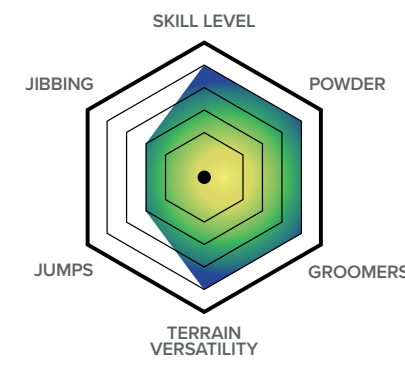

• TECH



143 147 151 155 *NEW!* BASE

R-SERIES RENTAL

R-SERIES RENTAL

