



SINCE 1995



thirtytwo

SIGNATURE - TURBO SERIES SOCKS



SIGNATURE SERIES SOCK

2023 / 2024

32 RIDER DRIVEN SNOWBOARDING

ASI

ADVANCED SOCK INTEGRATION IS OUR ALL NEW PLATFORM THAT INTEGRATES THE FIT FEATURES OF OUR ELITE AND ADVANCED BOOT LINERS WITH TECHNICAL YARNS CREATING THE ULTIMATE FIT EXPERIENCE IN PERFORMANCE RIDING SOCKS.

MAPPING THE KEY FIT AREAS IN OUR LINERS WE THEN USED MULTI-DENSITY KNITTING TO WEAVE TRI-LEVEL HIGHS AND LOWS THAT CORRESPONDED TO THESE INTERNAL LINER FEATURES TO CREATE AN UNRIVALED LEVEL OF TECHNICAL INTEGRATION, FIT, AND COMFORT IN 32 SOCKS

SIGNATURE SERIES SOCKS



Gold_710



Black_001



Teal_328



JONES MERINO ASI SOCK

FEATURES

- + Non Mulsed Merino Wool
- + Antimicrobial Spandex
- + Recycled Nylon
- + Stay Up Rib Cuff
- + Snug Fit Heel
- + Arch Support Rib Knit
- + Compression Ankle Rib Band
- + Achilles, Calf, And Shin Cushion
- + Toe and Heel Cushion
- + Reinforced Ghost Seam Toe Box

Code_8140000733

Size_S/M, L/XL | Fit_ASI FIT | Weight_MIDWEIGHT

Fabric_MERINO WOOL BLEND: 41.5% MERINO / 41.5% ACRYLIC / 15% NYLON / 2% SPANDEX



HALO SOCK

FEATURES

- + Graphene Yarn For Increased Circulation And Warmth
- + Stay Up Rib Cuff
- + Logo Embroidery On Cuff
- + Snug Fit Heel
- + Arch Support Rib Knit
- + Compression Ankle Rib Band
- + Toe And Heel Cushion
- + Reinforced Ghost Seam Toe Box

Code_8140000762

Size_S/M, L/XL | Fit_ASI FIT | Weight_MIDWEIGHT

Fabric_50% NYLON / 50% VISCOSE



Green_300



Black / White_976



TM COOLMAX SOCK

FEATURES

- + ASI Advanced Sock Integration Fit
- + Coolmax Moisture Wicking Yarns With Antimicrobial Spandex
- + Stay Up Rib Cuff
- + Logo Embroidery On Cuff
- + Snug Fit Heel
- + Arch Support Rib Knit
- + Compression Ankle Rib Band
- + Calf And Shin Cushion
- + Toe And Heel Cushion
- + Reinforced Ghost Seam Toe Box

Code_8140000763

Size_S/M, L/XL | Fit_ASI FIT | Weight_MIDWEIGHT

Fabric_SYNTHETIC SUPERIOR MOISTURE WICKING COOLMAX® BLEND: 41.5% COOLMAX / 41.5% COTTON / 15% NYLON / 2% SPANDEX



Black / White_976



Moss_344



Red / Black_603



Black / Blue_587



Black / Brown_590



Black / Silver_582



Black / White_976



Blue / Black_399



Blue / Tan_440



SIGNATURE MERINO SOCK

FEATURES

- ASI Advanced Sock Integration Fit
- Non Mulsed Merino Wool With Antimicrobial Spandex
- Stay Up Rib Cuff
- Logo Embroidery On Cuff
- Snug Fit Heel
- Arch Support Rib Knit
- Compression Ankle Rib Band
- Achilles, Calf, And Shin Cushion
- Toe And Heel Cushion
- Reinforced Ghost Seam Toe Box

Code_8140000764

Size_S/M, L/XL | Fit_ASI FIT | Weight_MIDWEIGHT

Fabric_MERINO WOOL BLEND: 41.5% MERINO / 41.5% ACRYLIC / 15% NYLON / 2% SPANDEX



DIGGERS MERINO SOCK

FEATURES

- ASI Advanced Sock Integration Fit
- Non Mulsed Merino Wool With Antimicrobial Spandex
- Stay Up Rib Cuff
- Logo Embroidery On Cuff
- Snug Fit Heel
- Arch Support Rib Knit
- Compression Ankle Rib Band
- Achilles, Calf, And Shin Cushion
- Toe And Heel Cushion
- Reinforced Ghost Seam Toe Box

Code_8140000766

Size_S/M, L/XL | Fit_ASI FIT | Weight_MIDWEIGHT

Fabric_MERINO WOOL BLEND: 41.5% MERINO / 41.5% ACRYLIC / 15% NYLON / 2% SPANDEX



SPRING BREAK SOCK

FEATURES

- Acrylic Yarn With Antimicrobial Spandex
- Stay Up Rib Cuff
- Logo Embroidery On Cuff
- Snug Fit Heel
- Arch Support Rib Knit
- Compression Ankle Rib Band
- Toe And Heel Cushion
- Reinforced Ghost Seam Toe Box

Code_8140000767

Size_S/M, L/XL | Fit_ASI FIT | Weight_MIDWEIGHT

Fabric_83% ACRYLIC / 15% NYLON / 2% SPANDEX



Yellow_700



Black / Green_985



Black / Charcoal_553



Black / Green_985



Yellow / White_720



White / Black_110



Black / Tan_975



Orange_800



Turquoise_452



TM MERINO SOCK

FEATURES

- + ASI Advanced Sock Integration Fit
- + Non Mulsed Merino Wool With Antimicrobial Spandex
- + Stay Up Rib Cuff
- + Logo Embroidery On Cuff
- + Snug Fit Heel
- + Arch Support Rib Knit
- + Compression Ankle Rib Band
- + Achilles, Calf, And Shin Cushion
- + Toe And Heel Cushion
- + Reinforced Ghost Seam Toe Box

Code_8140000765

Size_S/M, L/XL | Fit_ASI FIT | Weight_MIDWEIGHT

Fabric_MERINO WOOL BLEND: 41.5% MERINO / 41.5% ACRYLIC / 15% NYLON / 2% SPANDEX



DOUBLE SOCK

FEATURES

- + Acrylic Yarn With Antimicrobial Spandex
- + Stay Up Rib Cuff
- + Logo Embroidery On Cuff
- + Snug Fit Heel
- + Arch Support Rib Knit
- + Compression Ankle Rib Band
- + Toe And Heel Cushion
- + Reinforced Ghost Seam Toe Box

Code_8140000768

Size_S/M, L/XL | Fit_ASI FIT | Weight_MIDWEIGHT

Fabric_83% ACRYLIC / 15% NYLON / 2% SPANDEX



SLUSH SOCK

FEATURES

- + Coolmax Moisture Wicking Yarns With Antimicrobial Spandex
- + Ultra Breathable Construction
- + Stay Up Rib Cuff
- + Logo Embroidery On Cuff
- + Snug Fit Heel
- + Arch Support Rib Knit
- + Compression Ankle Rib Band
- + Toe And Heel Cushion
- + Reinforced Ghost Seam Toe Box

Code_8140000769

Size_S/M, L/XL | Fit_ASI FIT | Weight_LIGHTWEIGHT

Fabric_100% COOLMAX YARNS



Assorted_999



Aqua_449



Black / Pink_963



Camo_341



Pink / White_680



CUT OUT 3 PACK

SOCK

FEATURES

- + Acrylic yarn With Antimicrobial Spandex
- + Stay Up Rib Cuff
- + Logo Embroidery On Cuff
- + Snug Fit Heel
- + Arch Support Rib Knit
- + Compression Ankle Rib Band
- + Toe And Heel Cushion
- + Reinforced Ghost Seam Toe Box

Code_8140000770

Size_ S/M, L/XL | Fit_ ASI FIT | Weight_ MIDWEIGHT

Fabric_ 83% ACRYLIC / 15% NYLON / 2% SPANDEX



W'S MERINO

SOCK

FEATURES

- + ASI Advanced Sock Integration Fit
- + Non Mulshed Merino Wool With Antimicrobial Spandex
- + Stay Up Rib Cuff
- + Logo Embroidery On Cuff
- + Snug Fit Heel
- + Arch Support Rib Knit
- + Compression Ankle Rib Band
- + Achilles, Calf, And Shin Cushion
- + Toe And Heel Cushion
- + Reinforced Ghost Seam Toe Box

Code_8240000134

Size_ S/M, L/XL | Fit_ ASI FIT | Weight_ MIDWEIGHT

Fabric_ MERINO WOOL BLEND: 41.5% MERINO / 41.5% ACRYLIC / 15% NYLON / 2% SPANDEX



W'S MERINO B4BC

SOCK

FEATURES

- + ASI Advanced Sock Integration Fit
- + Non Mulshed Merino Wool With Antimicrobial Spandex
- + Stay Up Rib Cuff
- + Logo Embroidery On Cuff
- + Snug Fit Heel
- + Arch Support Rib Knit
- + Compression Ankle Rib Band
- + Achilles, Calf, And Shin Cushion
- + Toe And Heel Cushion
- + Reinforced Ghost Seam Toe Box

Code_8240000135

Size_ S/M, L/XL | Fit_ ASI FIT | Weight_ MIDWEIGHT

Fabric_ MERINO WOOL BLEND: 41.5% MERINO / 41.5% ACRYLIC / 15% NYLON / 2% SPANDEX



Floral_339



Pink_650



Deep Purple_517



Black_001



Black / Red_595



Black / Green_985



W'S DOUBLE SOCK

FEATURES

- + Acrylic Yarn With Antimicrobial Spandex
- + Stay Up Rib Cuff
- + Logo Embroidery On Cuff
- + Snug Fit Heel
- + Arch Support Rib Knit
- + Compression Ankle Rib Band
- + Toe And Heel Cushion
- + Reinforced Ghost Seam Toe Box

Code_8240000136

Size_S/M, L/XL | Fit_ASI FIT | Weight_MIDWEIGHT

Fabric_83% ACRYLIC / 15% NYLON / 2% SPANDEX



W'S JONES MERINO SOCK

FEATURES

- + Non Mulsed Merino Wool
- + Antimicrobial Spandex
- + Recycled Nylon
- + Stay Up Rib Cuff
- + Snug Fit Heel
- + Arch Support Rib Knit
- + Compression Ankle Rib Band
- + Achilles, Calf, And Shin Cushion
- + Toe and Heel Cushion
- + Reinforced Ghost Seam Toe Box

Code_8240000137

Size_S/M, L/XL | Fit_ASI FIT | Weight_MIDWEIGHT

Fabric_MERINO WOOL BLEND: 41.5% MERINO / 41.5% ACRYLIC / 15% NYLON / 2% SPANDEX



YOUTH DOUBLE SOCK

FEATURES

- + Acrylic Yarn With Antimicrobial Spandex
- + Stay Up Rib Cuff
- + Logo Embroidery On Cuff
- + Snug Fit Heel
- + Arch Support Rib Knit
- + Compression Ankle Rib Band
- + Toe And Heel Cushion
- + Reinforced Ghost Seam Toe Box

Code_8340000014

Size_ONE SIZE | Fit_ASI FIT | Weight_MIDWEIGHT

Fabric_83% ACRYLIC / 15% NYLON / 2% SPANDEX

**STAY DRY.
RIDE LONGER.**

32 REPEL

**WATER REPELLENT
TECHNOLOGY**



**32 REPEL IS OUR ACTIVE WATER REPELLENT TECHNOLOGY THAT PROVIDES PROTECTION FROM SNOW, WIND & RAIN.
32 REPEL IS A COATING THAT PREVENTS WATER SATURATION CAUSING SNOW AND RAIN TO BEAD UP AND ROLL OFF THE FABRIC.
IT PROVIDES HIGH PERFORMANCE WATER RESISTANCE & ENHANCES REACTIVE BREATHABILITY.**

SIMPLY PUT 32 REPEL KEEPS YOU DRY SO YOU CAN RIDE LONGER.

thirtytwo

CHECK THE TECH

OUTERWEAR

EVERYTHING YOU NEED AND NOTHING YOU DON'T! WE'RE NOT WASTING TIME WITH A BUNCH OF BS, WE SNOWBOARD WHETHER IT'S ZERO OR 65 OUT. SO YOU NEED OUTERWEAR THAT FITS PERFECT AND HAS ALL THE RIGHT FEATURES.



YKK® Aquaguard® Water Repellent Zippers For Unequaled Seal From The Harshest Mountain Conditions

DURABILITY



TRIPLE STITCH DURABILITY
Workwear Proven Craftsmanship



FULLY TAPED SEAMS
Complete Seal From The Elements



REINFORCED HEM & KICK PANEL
Increased Resistance Vs. Bindings



DROP SEAT FULL BUTT PANEL
Full Backcountry Access

PLUG & PLAY



HELMET COMPATIBLE HOOD
Seamless Fit With Or Without A Helmet



SNAP LOCK SYSTEM
Jacket To Pant Interface System



REMOVABLE HOOD
Integrated Zipper System



REMOVABLE WAIST GAITER
Removable With Zipper

MATERIALS



ANTI-MICROBIAL
No More Funky Smells



NATURAL MERINO WOOL
Soft Wool To Keep You Warm



ACRYLIC MATERIAL
Provides Shock Absorption



RECYCLED
Water Bottle Content



WATER BASED INKS
Softest Inks Around

WARMTH



THERMATWO INSULATION
Stay Heated When The Temps Drop



REACTOR MESH
Keep Heat & Release Perspiration



3D FLEECE ZONAL WARMING
Warm & Unrestricted Key Areas



WELDED SEAMS
Fused for Strength And Waterproofing



3 LAYER TRICOT FUSED
Lightweight Performance & Durability

COOLING



MESH LINED ZIPPERED VENTS
Quickly Dump Excess Heat



DIAMOND VENTING
Dual Zip / Diamond Gusseted Crotch Vent



MOISTURE WICKING
Keeps Your Skin Fresh



OUTERWEAR FIT GUIDE

NOTE: The following data is for **LARGE** size items. A full spec sheet is available on the following pages. *Note - Larger Snow Waist Size Accommodates Layering

FIT ^{LS}

MEN'S LOOSE

A roomy fit with more length and volume than our relaxed fit. Meant to feel loose and less structured.

MENS SIZE LARGE

CHEST	24 1/2"
ARM LENGTH	35"
LENGTH	37"

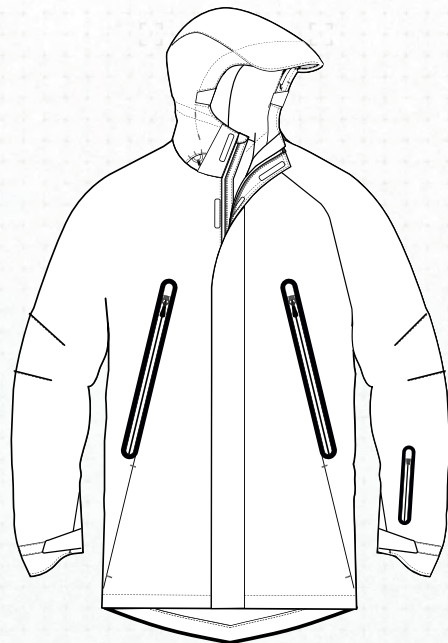

FIT ^{RLX}

MEN'S RELAXED

This fit offers plenty of room for ease of mobility, comfort, and layering.

MENS SIZE LARGE

CHEST	24"
ARM LENGTH	35"
LENGTH	34"

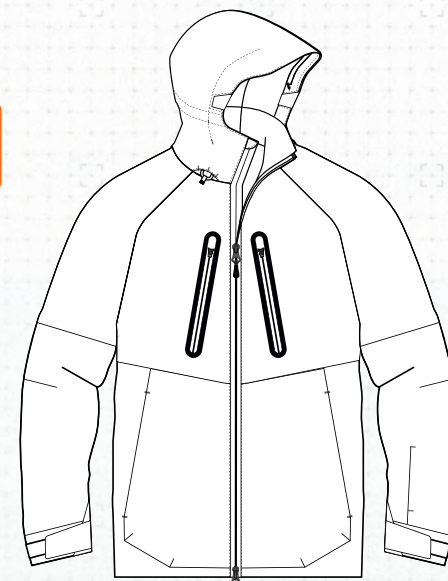

FIT ^{LS}

MEN'S LOOSE

A roomy fit with more length and volume than our relaxed fit. Meant to feel loose and less structured.

MENS SIZE LARGE

WAIST*	34" - 36"
HIP	47"
INSEAM	33"
LEG OPENING	23"

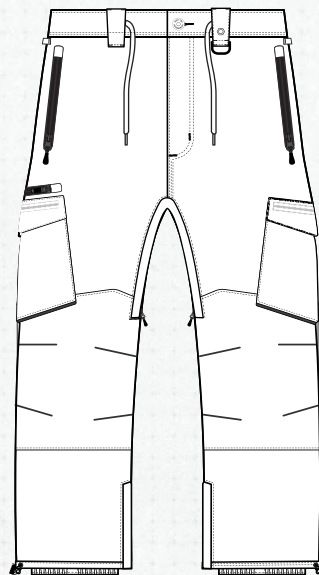

FIT ^{REG}

MEN'S REGULAR

What some might call a normal fit, regular-fitting garments are not too tight or too baggy, and can be worn over warmer mid-layer pieces with ease.

MENS SIZE LARGE

WAIST*	34" - 36"
HIP	44"
INSEAM	33"
LEG OPENING	20 1/2"

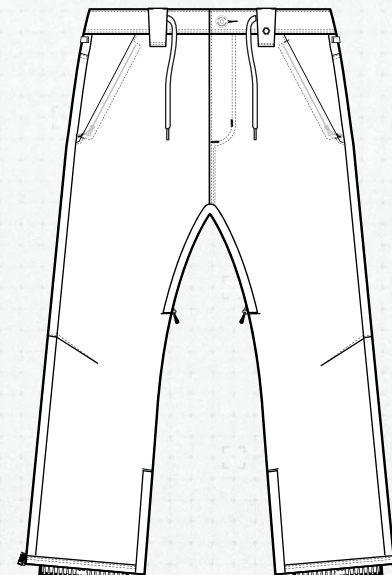



WOMEN'S

What some might call a normal fit, regular-fitting garments are not too tight or too baggy, and can be worn over warmer mid-layer pieces with ease.

WOMENS SIZE LARGE

CHEST	22"
ARM LENGTH	32"
LENGTH	31 1/2"

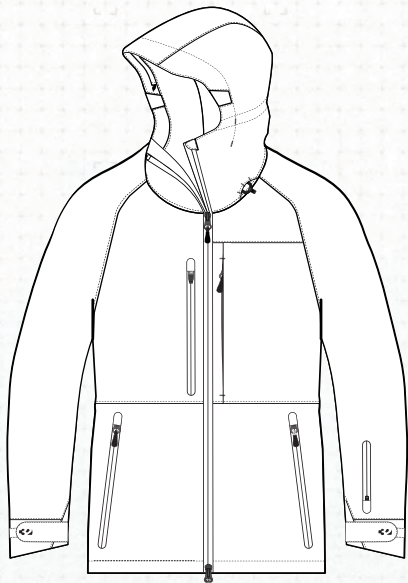

YOUTH

What some might call a normal fit, regular-fitting garments are not too tight or too baggy, and can be worn over warmer mid-layer pieces with ease.

YOUTH SIZE LARGE

AGE	8-12
CHEST	20"
ARM LENGTH	26"
LENGTH	28"

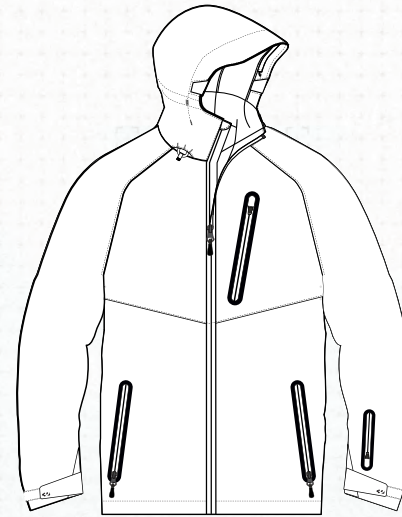

WOMEN'S

What some might call a normal fit, regular-fitting garments are not too tight or too baggy, and can be worn over warmer mid-layer pieces with ease.

WOMENS SIZE LARGE

WAIST*	37"
HIP	44"
INSEAM	33 1/2"
LEG OPENING	22 1/2"

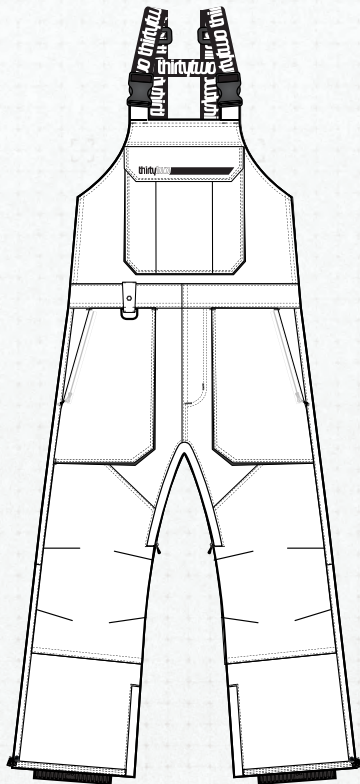

YOUTH

What some might call a normal fit, regular-fitting garments are not too tight or too baggy, and can be worn over warmer mid-layer pieces with ease.

YOUTH SIZE LARGE

WAIST*	32"
HIP	38"
INSEAM	26 1/2"
LEG OPENING	21"

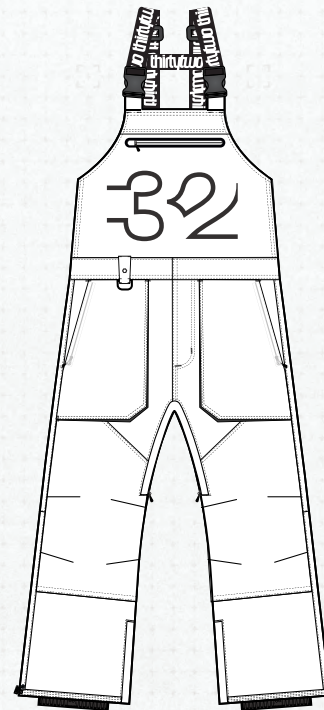

32

REGULAR FIT — MEN'S JACKETS & PANTS

Jacket: N/A / Pants: Wooderson — (Replaces Standard Fit) What some might call a normal fit, regular-fitting garments are not too tight or too baggy, and can be worn over warmer mid-layer pieces with ease.

Sizes:	Approximate Height:	Approximate Weight:	Chest:	Arm Length:	Length:	Waist:	Hip:	Inseam:	Leg Opening:
Small	5'6" - 5'9"	135 - 155 lbs	22	33"	32"	30-32"	40"	31"	19.5"
Medium	5'8" - 5'10"	155 - 170 lbs	23"	34"	33"	32-34"	42"	32"	20"
Large	5'10" - 6'1"	170 - 190 lbs	24"	35"	34"	34-36"	44"	33"	20.5"
X-Large	6'1" - 6'3"	190 - 210 lbs	26"	36"	35"	36-38"	46.5"	34.5"	21"
XX-Large	6'2" - 6'5"	210 - 230 lbs	27.5"	37"	36.5"	38-40"	49"	36"	22"

RELAXED FIT — MEN'S JACKETS & PANTS

Jackets: TM-3, TM, Lashed Insulated, Grasser Jacket, Light Anorak, Gateway / Pants: N/A — (Replaces Team Fit) This fit offers plenty of room for ease of mobility, comfort, and layering.

Sizes:	Approximate Height:	Approximate Weight:	Chest:	Arm Length:	Length (Back):	Waist:	Hip:	Inseam:	Leg Opening:
Small	5'6" - 5'9"	135 - 155 lbs	22	33"	32"	30-32"	41"	31"	21"
Medium	5'8" - 5'10"	155 - 170 lbs	23"	34"	33"	32-34"	43"	32"	21.5"
Large	5'10" - 6'1"	170 - 190 lbs	24"	35"	34"	34-36"	45"	33"	22"
X-Large	6'1" - 6'3"	190 - 210 lbs	26"	36"	35"	36-38"	47.5"	34.5"	23"
XX-Large	6'2" - 6'5"	210 - 230 lbs	27.5"	37"	36.5"	38-40"	50"	36"	23.5"

LOOSE FIT — MEN'S JACKETS & PANTS

Jacket: Spring Break Jacket, Deep Creek Jacket / Pants: TM-3 Bib, Deep Creek Bib, TM Pant, Basement Bib, Blahzay, Sweeper XLT, Sweeper, Spring Break Bib, Gateway — (Replaces Relaxed Fit) A roomy fit with more length and volume than our relaxed fit. Meant to feel loose and less structured.

Sizes:	Approximate Height:	Approximate Weight:	Chest:	Arm Length:	Length (Back):	Waist:	Hip:	Inseam:	Leg Opening:
Small	5'6" - 5'9"	135 - 155 lbs	22.5	33"	35"	30-32"	43"	31"	22"
Medium	5'8" - 5'10"	155 - 170 lbs	23.5"	34"	36"	32-34"	45"	32"	22.5"
Large	5'10" - 6'1"	170 - 190 lbs	24.5"	35"	37"	34-36"	47"	33"	23"
X-Large	6'1" - 6'3"	190 - 210 lbs	26.5"	36"	38"	36-38"	49.5"	34.5"	24"
XX-Large	6'2" - 6'5"	210 - 230 lbs	28"	37"	40"	38-40"	52"	36"	24.5"

WOMEN'S FIT

Jacket: Nova Jacket / Pant: Basement Bib — What some might call a normal fit, regular-fitting garments are not too tight or too baggy, and can be worn over warmer mid-layer pieces with ease.

Sizes:	Approximate Height:	Approximate Size:	Chest:	Arm Length:	Length (Back):	Waist on Bib:	Hip:	Inseam:	Leg Opening:
X-Small	5.0" - 5.2"	2 - 4	19"	29"	28.5"	31"	38"	30.5"	21"
Small	5.1" - 5.4"	4 - 6	20"	30"	29.5"	33"	40"	31.5"	21.5"
Medium	5.4" - 5.7"	6 - 8	21"	31"	30.5"	35"	42"	32.5"	22"
Large	5.5" - 5.9"	8 - 10	22"	32"	31.5"	37"	44"	33.5"	22.5"
X-Large	5.8" - 6.0"	10 - 12	23.5"	33"	32.5"	39"	46"	34.5"	23"

YOUTH FIT

Jacket: Grasser Insulated Jacket / Pant: Basement Bib — What some might call a normal fit, regular-fitting garments are not too tight or too baggy, and can be worn over warmer mid-layer pieces with ease.

Sizes:	Approximate Height:	Approximate Size:	Approximate Age:	Chest:	Arm Length:	Length (Back):	Waist on Bib:	Hip:	Inseam:	Leg Opening:
Small	4.6" - 4.8"	7	6 - 7	18"	24"	26"	28"	35"	24.5"	20"
Medium	4.8" - 4.10"	9 - 10	7 - 10	19"	25"	27"	30"	36.5"	25.5"	20.5"
Large	4.10" - 5.0"	12	10 - 12	20"	26"	28"	32"	38"	26.5"	21"
X-Large	5.0" - 5.2"	14 - 16	13 - 16	21"	27"	29"	34"	40"	28"	22"

SIZING IN CENTIMETERS

REGULAR FIT — MEN'S JACKETS & PANTS

Jacket: N/A / Pants: Wooderson — (Replaces Standard Fit) What some might call a normal fit, regular-fitting garments are not too tight or too baggy, and can be worn over warmer mid-layer pieces with ease.

Sizes:	Approximate Height:	Approximate Weight:	Chest:	Arm Length:	Length:	Waist:	Hip:	Inseam:	Leg Opening:
Small	167-175	60-70	56	84	81	76-81	101.5	79	49.5
Medium	172-178	70-77	58.5	86	84	81-86	107	81	51
Large	178-185	70-86	61	89	86	86-91	112	84	52
X-Large	185-190	86-95	66	91	89	91-96	118	88	53
XX-Large	188-195	95-104	70	94	93	96-101	125	91.5	56

RELAXED FIT — MEN'S JACKETS & PANTS

Jackets: TM-3, TM, Lashed Insulated, Grasser Jacket, Light Anorak, Gateway / Pants: N/A — (Replaces Team Fit) This fit offers plenty of room for ease of mobility, comfort, and layering.

Sizes:	Approximate Height:	Approximate Weight:	Chest:	Arm Length:	Length (Back):	Waist:	Hip:	Inseam:	Leg Opening:
Small	167-175	60-70	56	84	81	76-81	104	79	53
Medium	172-178	70-77	58.5	86	84	81-86	110	81	53
Large	178-185	70-86	61	89	86	86-91	114	84	56
X-Large	185-190	86-95	66	91	89	91-96	121	88	58.5
XX-Large	188-195	95-104	70	94	93	96-101	127	91.5	60

LOOSE FIT — MEN'S JACKETS & PANTS

Jacket: Spring Break Jacket, Deep Creek Jacket / Pants: TM-3 Bib, Deep Creek Bib, TM Pant, Basement Bib, Blahzay, Sweeper XLT, Sweeper, Spring Break Bib, Gateway — (Replaces Relaxed Fit) A roomy fit with more length and volume than our relaxed fit. Meant to feel loose and less structured.

Sizes:	Approximate Height:	Approximate Weight:	Chest:	Arm Length:	Length (Back):	Waist:	Hip:	Inseam:	Leg Opening:
Small	167-175	60-70	57	84	89	76-81	109	79	56
Medium	172-178	70-77	60	86	91	81-86	114	81	57
Large	178-185	77-86	62	89	94	86-91	119	84	58.5
X-Large	185-190	86-95	67	91	96	91-96	126	88	61
XX-Large	188-195	95-104	71	94	101	96-101	132	91	62

WOMEN'S FIT

Jacket: Nova Jacket / Pant: Basement Bib — What some might call a normal fit, regular-fitting garments are not too tight or too baggy, and can be worn over warmer mid-layer pieces with ease.

Sizes:	Approximate Height:	Approximate Size (UK):	Approximate Size (EU):	Chest:	Arm Length:	Length (Back):	Waist on Bib:	Hip:	Inseam:	Leg Opening:
X-Small	152-157	6-8	34-36	48	74	72	79	97	77	53
Small	155-162	8-10	36-38	51	76	75	84	102	80	55
Medium	162-170	10-12	38-40	53	79	77.5	89	107	82.5	56
Large	165-175	12-14	40-42	56	81	80	94	112	85	57
X-Large	172-182	14-16	42-44	60	84	82.5	99	117	87.5	58

YOUTH FIT

Jacket: Grasser Insulated Jacket / Pant: Basement Bib — What some might call a normal fit, regular-fitting garments are not too tight or too baggy, and can be worn over warmer mid-layer pieces with ease.

Sizes:	Approximate Height:	Approximate Size (UK):	Approximate Size (EU):	Chest:	Arm Length:	Length (Back):	Waist on Bib:	Hip:	Inseam:	Leg Opening:
Small	137-142	7-8	122-128	45.5	61	66	71	89	82	51
Medium	142-147	9-10	134-140	48	63.5	69	76	93	85	52
Large	147-152	11-13	146-158	51	66	71	81	96.5	87	53
X-Large	152-157	14-16	164-172	53	69.5	74	86	101.5	71	56

JACKET TM-3

The new TM-3 Jacket is made with 100% recycled 3 layer fused fabric. Designed to stand at the apex of style, tech, and warmth, the TM-3 Jacket is the ultimate blend of technical function and comfort for the most stormy of days on the hill.

FEATURES

- 100% Recycled 4-Way Stretch Fused 3 Layer Fabric
- 25,000mm Waterproofing / 25,000gm2 Breathability
- Fused and Taped Seams
- 2-Way Water Repellent Zippers
- New Ergonomic Adjustable Hood with Improved Peripheral
- Stormguard Zippered Vents
- Stretch Waist Baiter with Updated Snap Loop Pant Interface
- Mesh Goggle Pockets
- Brushed Tricot Pocket Lining
- Media Pocket
- Hidden Bungee Hem
- Quick Stash Sleeve Pass Pocket
- Stretch Wrist Gaiters
- Adjustable Inset Velcro Wrist Cinch

Code_8130001182

Size_ S, M, L, XL, XXL

32 REPEL_25,000MM WATERPROOFING / 25,000GM2 BREATHABILITY

Fabric_100% RECYCLED 25/25 REPEL 4-WAY STRETCH FUSED 3 LAYER FABRIC

Fit_RELAXED FIT



Black / Olive_592

TM-3 BIB

The new TM-3 Bib is made with 100% recycled 3 layer fused fabric. Designed to stand at the apex of style, tech, and warmth, the TM-3 Bib is the ultimate blend of technical and comfort for the most stormy of days on the hill.

FEATURES

- + 100% Recycled 4-Way Stretch Fused 3 Layer Fabric
- + 25,000mm Waterproofing / 25,000gm2 Breathability
- + Fused and Taped Seams
- + Water Repellent Zippers
- + Shoulder Straps with Logo Art and Release Clips
- + Chest Pockets
- + Center Front Zip for Easy Access
- + Stormguard Crotch Venting
- + Reinforced Butt Patch
- + Triple Stitched Reinforced Rise and Inseam
- + Brushed Tricot Pocket Lining
- + Hip Vents
- + Articulated Knee Patches
- + Stretch Boot Gaiter With Lace Hook
- + Zippered Boot Gusset

Code_B130001183

Size _S, M, L, XL, XXL

32 REPEL_25,000MM WATERPROOFING / 25,000GM2 BREATHABILITY

Fabric_100% RECYCLED 25/25 REPEL 4-WAY STRETCH FUSED 3 LAYER FABRIC

Fit_LOOSE FIT



Black_001

SPRING BREAK PARKA PINTAIL POWDER

The new Spring Break Parka ignites a new era of high performance collaboration. Designed to the exact specifications of Corey Smith we set out to build the perfect deep pow parka. Elevated with 32 REPEL 20K fabrication, the Spring Break Powder Parka blends timeless style with critical white room performance.

FEATURES

- 20,000mm Waterproofing / 20,000gm2 Breathability
- 4-Way Stretch Fused 2 Layer Fabric
- 2-Way Zipper With Storm Flap
- Water Repellent Chest Pockets
- New Ergonomic Removable Hood with Improved Peripheral
- Lined Zippered Vents
- Stretch Waist Gaiter with Updated Snap Loop Pant Interface
- Mesh Goggle Pockets
- Brushed Tricot Pocket Lining
- Quick Stash Sleeve Pass Pocket
- Stretch Wrist Gaiters
- Adjustable Wrist Cinch

Code_8130001184

Size _S, M, L, XL, XXL

32 REPEL_20,000MM WATERPROOFING / 20,000GM2 BREATHABILITY

Fabric_20/20 REPEL 4-WAY STRETCH FUSED 2 LAYER FABRIC

Fit_LOOSE FIT



Blue_400

SPRING BREAK BIB POWDER

The new Spring Break Powder Bib ignites a new era of high performance collaboration. Designed to the exact specifications of Corey Smith we set out to build the perfect deep pow bib. Featuring our pinnacle 32 REPEL 20K Dura-Stretch fabric, our exclusive Reactor Mesh Thermo Responsive Lining, Dual Hip Venting, Full Drop Seat Access Front Zip design the Spring Break Powder Bib blends timeless style with critical white room performance.

FEATURES

- + 20,000mm Waterproofing / 20,000gm2 Breathability
- + 4-Way Stretch Fused 2 Layer Fabric
- + Taped Seams
- + Water Repellent Zippers
- + Drop Seat Full Butt Panel
- + Shoulder Straps with Logo Art and Release Clips
- + Chest Pockets
- + Center Front Zip for Easy Access
- + Mesh Lined Crotch Venting
- + Reinforced Butt Patch
- + Triple Stitched Reinforced Rise and Inseam
- + Brushed Tricot Pocket Lining
- + Hip Vents
- + Articulated Knee Patches
- + Stretch Boot Gaiter With Lace Hook
- + Zippered Boot Gusset with Integrated Toggle

Code_ B130001185

Size_ S, M, L, XL, XXL

32 REPEL_ 20,000MM WATERPROOFING / 20,000GM2 BREATHABILITY

Fabric_ 20/20 REPEL 4-WAY STRETCH FUSED 2 LAYER FABRIC

Fit_ LOOSE FIT



Blue_400

DEEP CREEK

PARKA

The Deep Creek Parka is back by popular demand. True parka fit for those that want a little more style on the hill. Chris Bradshaw's favorite.

FEATURES

- + 20,000mm Waterproofing / 20,000gm2 Breathability
- + 4-Way Stretch Fused 2 Layer Fabric
- + 2-Way Zipper With Storm Flap
- + Water Repellent Chest Pockets
- + New Ergonomic Removable Hood with Improved Peripheral
- + Lined Zippered Vents
- + Stretch Waist Gaiter with Updated Snap Loop Pant Interface
- + Mesh Goggle Pockets
- + Brushed Tricot Pocket Lining
- + Quick Stash Sleeve Pass Pocket
- + Stretch Wrist Gaiters
- + Adjustable Wrist Cinch

Code_8130001186

Size _S, M, L, XL, XXL

32 REPEL_20,000MM WATERPROOFING / 20,000GM2 BREATHABILITY

Fabric_20/20 REPEL 4-WAY STRETCH FUSED 2 LAYER FABRIC

Fit_RELAXED FIT



Black_001

DEEP CREEK BIB

The new Deep Creek Bib ignites a new era of high performance collaboration. Designed to the exact specifications of our team riders so we set out to build the perfect deep pow bib. Featuring our pinnacle 32 REPEL 20K Dura-Stretch fabric, our exclusive Reactor Mesh Thermo Responsive Lining, Dual Hip Venting, Full Drop Seat Access Front Zip design the Spring Break Powder Bib blends timeless style with critical white room performance.

FEATURES

- + 20,000mm Waterproofing / 20,000gm2 Breathability
- + 4-Way Stretch Fused 2 Layer Fabric
- + Taped Seams
- + Water Repellent Zippers
- + Drop Seat Full Butt Panel
- + Shoulder Straps with Logo Art and Release Clips
- + Chest Pockets
- + Center Front Zip for Easy Access
- + Mesh Lined Grotch Venting
- + Reinforced Butt Patch
- + Triple Stitched Reinforced Rise and Inseam
- + Brushed Tricot Pocket Lining
- + Hip Vents
- + Articulated Knee Patches
- + Stretch Boot Gaiter With Lace Hook
- + Zippered Boot Gusset with Integrated Toggle

Code_ B130001187

Size_ S, M, L, XL, XXL

32 REPEL_ 20,000MM WATERPROOFING / 20,000GM2 BREATHABILITY

Fabric_ 20/20 REPEL 4-WAY STRETCH FUSED 2 LAYER FABRIC

Fit_ LOOSE FIT



Black_001

TM
JACKET

The new TM Jacket is made with 100% recycled 2 layer fused fabric. Featuring our exclusive Reactor Mesh Thermo Responsive Lining and 3D Fleece Zonal Warming Panels the TM Jacket sets the new benchmark for cold weather tech blended with modern mountain style. Chris Grenier's favorite jacket.

FEATURES

- + 100% Recycled 4-Way Stretch Fused 2 Layer Fabric
- + 20.000mm Waterproofing / 20.000gm2 Breathability
- + Taped Seams
- + Water Repellent Zippers
- + Metal Shank Waistband Closure
- + Adjustable Waistband
- + Mesh Lined Crotch Venting
- + Snap Loop Jacket Interface
- + Back Pockets with Velcro Closure
- + Front Facing Cargo Pockets
- + Reinforced Butt Patch
- + Triple Stitched Reinforced Rise and Inseam
- + Brushed Tricot Pocket Lining
- + Articulated Knee Patches
- + Stretch Boot Gaiter With Lace Hook
- + Zippered Boot Gusset

Code_8130001188

Size_S, M, L, XL, XXL

32 REPEL_20.000MM WATERPROOFING / 20.000GM2 BREATHABILITY

Fabric_100% RECYCLED 20/20 REPEL 4-WAY STRETCH FUSED 2 LAYER FABRIC

Fit_RELAXED FIT



Camo_341



Orange_800



Black_001



TM
PANT

The new TM Pant is made with 100% recycled 2 layer fused fabric. Featuring our exclusive Reactor Mesh Thermo Responsive Lining and 3D Fleece Zonal Warming Panels the TM Pant with its Loose Fit sets the new benchmark for cold weather tech blended with modern mountain style.

FEATURES

- + 100% Recycled 4-Way Stretch Fused 2 Layer Fabric
- + 20,000mm Waterproofing / 20,000gm2 Breathability
- + Taped Seams
- + Water Repellent Zippers
- + Metal Shank Waistband Closure
- + Adjustable Waistband
- + Mesh Lined Crotch Venting
- + Updated Snap Loop Jacket Interface
- + Back Pockets with Velcro Closure
- + Front Facing Cargo Pockets
- + Reinforced Butt Patch
- + Triple Stitched Reinforced Rise and Inseam
- + Brushed Tricot Pocket Lining
- + Articulated Knee Patches
- + Stretch Boot Gaiter With Lace Hook
- + Zippered Boot Gusset

Code_813000189

Size_S, M, L, XL, XXL

32 REPEL 20,000MM WATERPROOFING / 20,000GM2 BREATHABILITY

Fabric_100% RECYCLED 20/20 REPEL 4-WAY STRETCH FUSED 2 LAYER FABRIC

Fit_LOOSE FIT



White / Camo_124



Military_343



Black_001

LASHED JACKET

The Lashed Jacket is the definition of modern clean design blended with technical simplicity. Focusing on a refined performance aesthetic the new Lashed Jacket maximizes critical 32 REPEL 15K fabrication with balanced 15K Breathability for a true equilibrium of performance.

FEATURES

- + 15,000mm Waterproofing / 15,000gm2 Breathability
- + 4-Way Stretch Fused 2 Layer Fabric
- + Taped Seams
- + 2-Way Water Repellent Zippers
- + New Ergonomic Adjustable Hood with Improved Peripheral
- + Mesh Lined Zippered Vents
- + Stretch Waist Gaiter with Updated Snap Loop Pant Interface
- + Goggle Pockets
- + Brushed Tricot Pocket Lining
- + Media Pocket
- + Hidden Bungie Hem
- + Quick Stash Sleeve Pass Pocket
- + Stretch Wrist Gaiters
- + Adjustable Wrist Cinch

Stevens Lashed_8130001190*
Lashed Insulated_8130001191

Size_S, M, L, XL, XXL

32 REPEL_15,000MM WATERPROOFING / 15,000GM2 BREATHABILITY

Fabric_15/15 REPEL 4-WAY STRETCH FUSED 2 LAYER FABRIC

Fit_RELAXED FIT



Haze_746*



Olive_301



Black / Blue_587



Black_001

BASEMENT

BIB

The Basement Bib has been setting the benchmark for bibs since day one. With its Rider Driven legacy the Basement Bib raises the bar yet again with a 32 REPEL 15K Dura-Stretch fabric upgrade and reinforced construction. Featuring our Loose Fit and triple stitched for durability.

FEATURES

- + 15,000mm Waterproofing / 15,000gm2 Breathability
- + Taped Seams
- + 4-Way Stretch Fused 2 Layer Fabric
- + Shoulder Straps with Logo Art and Release Clips
- + Kangaroo Chest Pocket
- + Side Zippered Entry
- + Crotch Fly for Easy Access
- + Mesh Lined Crotch Venting
- + Reinforced Butt Patch
- + Belt Loops
- + Triple Stitched Reinforced Rise and Inseam
- + Brushed Tricot Pocket Lining
- + Articulated Knee Patches
- + Stretch Boot Gaiter With Lace Hook
- + Zippered Boot Gusset with Updated Hem Toggle

Code_8130001192

Size_S, M, L, XL, XXL

32 REPEL_15,000MM WATERPROOFING / 15,000GM2 BREATHABILITY

Fabric_15/15 REPEL 4-WAY STRETCH FUSED 2 LAYER FABRIC

Fit_LOOSE FIT



Charcoal_010



Khaki_255



Black / Orange_960



Black_001

LIGHT
ANORAK

For the Light Anorak JP took his decade plus experience of wearing Thirtytwo outerwear and focused all his wisdom and passion into designing the perfect all terrain anorak. With 32 REPEL 15K fabrication, streamlined modern styling, and a Team Level Lining System JP's light and lean design benchmarks a new approach in anorak design.

FEATURES

- 15,000mm Waterproofing / 15,000gm2 Breathability
- 4-Way Stretch Fused 2 Layer Fabric
- Water Repellent Zippers
- Taped Seams
- New Ergonomic Adjustable Hood with Improved Peripheral
- Brushed Tricot Pocket Lining
- Media Pocket
- 2-Way Kangaroo Pocket
- Hidden Bungie Hem
- Quick Stash Sleeve Pass Pocket
- Stretch Wrist Gaiters
- Adjustable Wrist Cinch

Code_8130001194

Size_S, M, L, XL, XXL

32 REPEL_15,000MM WATERPROOFING / 15,000GM2 BREATHABILITY

Fabric_15/15 REPEL 4-WAY STRETCH FUSED 2 LAYER FABRIC

Fit_RELAXED FIT



mkd
WALKER

White / Camo_124



Military_343

WOODERSON PANT

The Wooderson Pant has been our top selling, team driven pant for the past 10 years running. Featuring 32 REPEL 15K Dura-Stretch fabric for unlimited mobility and a timeless chino look.

FEATURES

- + 15,000mm Waterproofing / 15,000gm2 Breathability
- + Taped Seams
- + 4-Way Stretch Fused 2 Layer Fabric
- + Reversed Coil Zippers
- + Metal Shank Waistband Closure
- + Tunneling Drawcord Waist
- + Mesh Lined Crotch Venting
- + Snap Loop Jacket Interface
- + Back Patch Pockets with Velcro Closure
- + Triple Stitched Reinforced Rise and Inseam
- + Brushed Tricot Pocket Lining
- + Stretch Boot Gaiter With Lace Hook
- + Zippered Boot Gusset

Code_ 8130001193

Size_ XS, S, M, L, XL, XXL

32 REPEL_ 15,000MM WATERPROOFING / 15,000GM2 BREATHABILITY

Fabric_ 15/15 REPEL 4-WAY STRETCH FUSED 2 LAYER FABRIC

Fit_ REGULAR FIT



Khaki_255



Black_001

GRASSER JACKET

The Grasser gets a technical upgrade to 32 REBEL 15K with fused 3 layer technical fabric to elevate performance. The Grasser Jacket can take you from peak to park with high grade tech and refined all mountain styling without breaking the bank.

FEATURES

- 15,000mm Waterproofing / 15,000gm² Breathability
- 4-Way Stretch Fused 3 Layer Fabric
- Taped Seams
- 2-Way Water Repellent Zipper
- New Ergonomic Adjustable Hood with Improved Peripheral
- Brushed Tricot Pocket Lining
- Media Pocket
- Hidden Bungie Hem
- Quick Stash Sleeve Pass Pocket
- Adjustable Cuff

Code_B130001196

Size_S, M, L, XL, XXL

32 REPEL_15,000MM WATERPROOFING / 15,000GM² BREATHABILITY

Fabric_15/15 REPEL 4-WAY STRETCH FUSED 3 LAYER FABRIC

Fit_RELAXED FIT



Blue / Black_587



Military_343



Black_001

BLAHZAY

CARGO

The Blahzay Cargo raises the bar with timeless styling, technical performance and easy-fit comfort that's built to last. Featuring 32 REPEL 15K fabrication, Loose Fit, Diamond Gusset Venting, clean cargo pockets and a fit that let's you look good and feel good.

FEATURES

- + 15,000mm Waterproofing / 15,000gm2 Breathability
- + 4-Way Stretch Fused 2 Layer Fabric
- + Taped Seams
- + Reverse Coil Zippers
- + Metal Shank Waistband Closure
- + Mesh Lined Crotch Vents
- + Snap Loop Jacket Interface
- + Back Pockets with Velcro Closure
- + Cargo Pockets
- + Triple Stitched Reinforced Rise and Inseam
- + Brushed Tricot Pocket Lining
- + Articulated Knee Patches
- + Stretch Boot Gaiter With Lace Hook
- + Zippered Boot Gusset with Updated Hem Toggle

Code_8130001195

Size_XS, S, M, L, XL, XXL

32 REPEL_15,000MM WATERPROOFING / 15,000GM2 BREATHABILITY

Fabric_15/15 REPEL 4-WAY STRETCH FUSED 2 LAYER FABRIC

Fit_LOOSE FIT



Khaki_255



Charcoal_010



Black_001

SWEeper XLT

PANT

Zeb Powell's signature pant takes everything you love about the Sweeper and elevates it. Added thigh pockets and mesh lined zippered vents make this the ideal pant for Zeb.

FEATURES

- 15,000mm Waterproofing / 15,000gm2 Breathability
- 4-Way Stretch Fused 2 Layer Fabric
- Taped Seams
- Elastic Waistband with Hidden Drawcord Waist Cinch
- Reverse Coil Zippers
- Mesh Lined Crotch Vents
- Cargo Pockets
- Updated Snap Loop Jacket Interface
- Zippered Back Pockets
- Triple Stitched Reinforced Rise and Inseam
- Brushed Tricot Pocket Lining
- Knee Patches
- Stretch Boot Gaiter With Lace Hook

Code_ B130001197

Size_ S, M, L, XL, XXL

32 REPEL_ 15,000MM WATERPROOFING / 15,000GM2 BREATHABILITY

Fabric_ 15/15 REPEL 4-WAY STRETCH FUSED 2 LAYER FABRIC

Fit_ LOOSE FIT



Black_001

SWEeper

PANT

The brainchild of Scott Stevens and JP Walker, the Sweeper Pant continues its legacy as the most stylish, easy riding pant on the mountain. With its unique mix of old school sweat pant styling, and modern fully taped 32 REPEL 15K tech, the Sweeper Pant blends together the best ideas of Scott and JP into a shred ready pant that can hold its own from deep pow to down rails in the park.

FEATURES

- 15,000mm Waterproofing / 15,000gm2 Breathability
- 4-Way Stretch Fused 2 Layer Fabric
- Taped Seams
- Elastic Waistband with Hidden Drawcord Waist Cinch
- Reverse Coil Zippers
- Updated Snap Loop Jacket Interface
- Zippered Back Pockets
- Triple Stitched Reinforced Rise and Inseam
- Brushed Tricot Pocket Lining
- Knee Patches
- Stretch Boot Gaiter With Lace Hook
- Velcro Adjustable Cuff Closure

Code_ 8130001198

Size_ S, M, L, XL, XXL

32 REPEL 15,000MM WATERPROOFING / 15,000GM2 BREATHABILITY

Fabric_ 15/15 REPEL 4-WAY STRETCH FUSED 2 LAYER FABRIC

Fit_ LOOSE FIT



mkt
STEVENS



Haze_746



Black_001

GATEWAY

JACKET

The Gateway Jacket wants to make snowboarding accessible to everyone and offer top level tech to keep you dry and warm. Taped 32 REPEL 15K construction. Waterproof Zippers, Full Gussets, Waist Gaiter, and Adjustable Hood are just some of the features in this go anywhere jacket.

FEATURES

- + 15,000mm Waterproofing / 15,000gm2 Breathability
- + 4-Way Stretch Fused 2 Layer Fabric
- + Taped Seams
- + 2-Way Water Repellent Zipper
- + New Ergonomic Adjustable Hood with Improved Peripheral
- + Brushed Tricot Pocket Lining
- + Hidden Bungee Hem
- + Stash Sleeve Pass Pocket
- + Adjustable Cuff

Code_B130001199

Size_S, M, L, XL, XXL

32 REPEL_15,000MM WATERPROOFING / 15,000GM2 BREATHABILITY

Fabric_15/15 REPEL 4-WAY STRETCH FUSED 2 LAYER FABRIC

Fit_RELAXED FIT



Charcoal_010

GATEWAY

PANT

The Gateway Pant wants to make snowboarding accessible to everyone and offer top level tech to keep you dry and warm. Taped 32 REPEL 15K tech. Zippered Vents, Full Gussets with Zippered Access are just some of the features in this go anywhere pant.

FEATURES

- 15,000mm Waterproofing / 15,000gm2 Breathability
- 4-Way Stretch Fused 2 Layer Fabric
- Taped Seams
- Reversed Coil Zippers
- Metal Shank Waistband Closure
- Tunneling Drawcord Waist
- Mesh Lined Crotch Venting
- Triple Stitched Reinforced Rise and Inseam
- Brushed Tricot Pocket Lining
- Stretch Boot Gaiter With Lace Hook
- Zippered Boot Gusset

Code_8130001200

Size _S. M. L. XL. XXL

32 REPEL_15,000MM WATERPROOFING / 15,000GM2 BREATHABILITY

Fabric_15/15 REPEL 4-WAY STRETCH FUSED 2 LAYER FABRIC

Fit_LOOSE FIT



Black_001



WOMENS

OUT



WEAR

OUTERWEAR

W

D

V

R

M

S

W O M E N S O U T E R W E A R



W'S BASEMENT
32 WOMENS OUTERWEAR
B I B 2022 / 2023



W'S NOVA
32 WOMENS OUTERWEAR
JACKET 2022 / 2023



W'S BASEMENT
32 WOMENS OUTERWEAR
B I B 2022 / 2023

thirtytwo

W'S NOVA

JACKET

The Women's Nova Jacket takes distinctive cues from the TM Jacket. Featuring REPEL 15K, articulated wrist cinches, new sleeve pass pocket, and lightweight construction throughout. A jacket for all weather conditions with a women's specific fit.

FEATURES

- 15,000mm Waterproofing / 15,000gm² Breathability
- 4-Way Stretch Fused 2 Layer Fabric
- Taped Seams
- 2-Way Water Repellent Zippers
- New Ergonomic Adjustable Hood with Improved Peripheral
- Mesh Lined Zippered Vents
- Waist Gaiter with Updated Snap Loop Pant Interface
- Mesh Goggle Pockets
- Brushed Tricot Pocket Lining
- Media Pocket
- Hidden Bungie Hem
- Quick Stash Sleeve Pass Pocket
- Stretch Wrist Gaiters
- Adjustable Wrist Cinch



Tan_260



Black_001

Code_B230000138

Size_XS, S, M, L, XL

32 REPEL_15,000MM WATERPROOFING / 15,000GM² BREATHABILITY

Fabric_15/15 REPEL 4-WAY STRETCH FUSED 2 LAYER FABRIC

Fit_WOMEN'S FIT

W'S BASEMENT BIB

The Basement Bib has been setting the benchmark for bibs since day one. Now in women's sizing it raises the bar yet again with a 32 REPEL 15K Dura-Stretch fabric upgrade and reinforced construction. Featuring our roomy relaxed Women's Fit and triple stitched durability the Basement Bib will have even the last pant wearers on the mountain making the switch to bibs.

FEATURES

- + 15,000mm Waterproofing / 15,000gm² Breathability
- + 4-Way Stretch Fused 2 Layer Fabric
- + Taped Seams
- + Shoulder Straps with Logo Art and Release Clips
- + Chest Pocket
- + Extended Side Zipper Entry
- + Mesh Lined Crotch Venting
- + Reinforced Butt Patch
- + Triple Stitched Reinforced Rise and Inseam
- + Brushed Tricot Pocket Lining
- + Articulated Knee Patches
- + Stretch Boot Gaiter With Lace Hook
- + Zippered Boot Gusset

Code_B230000139

Size_XS, S, M, L, XL

32 REPEL_15,000MM WATERPROOFING / 15,000GM² BREATHABILITY

Fabric_15/15 REPEL 4-WAY STRETCH FUSED 2 LAYER FABRIC

Fit_WOMEN'S FIT



Tan_260



Black_001

Y'S GRASSER INSULATED JACKET

The Youth Grasser Jacket has all the best features of the men's jacket, but with added insulation and upgraded 32 REPEL 15K waterproofing. With an internal waist gaiter, stealth external chest pocket, Youth Fit and Team Level Lining System the new Youth Grasser Jacket can take you from peak to park with high grade tech and refined all mountain styling without breaking the bank.

FEATURES

- 15,000mm Waterproofing / 15,000gm2 Breathability
- 4-Way Stretch Fused 2 Layer Fabric
- 120G Body / 100G Sleeve Insulation
- Taped Seams
- 2-Way Water Repellent Zippers
- New Ergonomic Adjustable Hood with Improved Peripheral
- Mesh Lined Zippered Vents
- Stretch Waist Gaiter
- Goggle Pockets
- Brushed Tricot Pocket Lining
- Media Pocket, Hidden Bungee Hem
- Quick Stash Sleeve Pass Pocket
- Adjustable Wrist Cinch

Code_B9390000021

Size_S, M, L, XL

32 REPEL_15,000MM WATERPROOFING / 15,000GM2 BREATHABILITY

Fabric_15/15 REPEL 4-WAY STRETCH FUSED 2 LAYER FABRIC

Fit_YOUTH FIT



Black / Orange_960



Haze_746

Y'S BASEMENT BIB

The Youth Basement Bib has been setting the benchmark for bibs since day one. Now in youth sizing it raises the bar yet again with a 32 REPEL 15K Dura-Stretch fabric upgrade and reinforced construction. Featuring our roomy relaxed Standard Fit and triple stitched durability the Basement Bib will keep every kid warm and cozy on the mountain.

FEATURES

- + 15,000mm Waterproofing / 15,000gm2 Breathability
- + 4-Way Stretch Fused 2 Layer Fabric
- + 120G Body / 100G Sleeve Insulation
- + Taped Seams
- + Shoulder Straps with Logo Art and Release Clips
- + Zippered Chest Pocket
- + Side Zippered Entry
- + Crotch Fly for Easy Access
- + Reinforced Butt Patch
- + Triple Stitched Reinforced Rise and Inseam
- + Brushed Tricot Pocket Lining
- + Articulated Knee Patches
- + Stretch Boot Gaiter With Lace Hook

Code_8330000022

Size_S, M, L, XL

32 REPEL_15,000MM WATERPROOFING / 15,000GM2 BREATHABILITY

Fabric_15/15 REPEL 4-WAY STRETCH FUSED 2 LAYER FABRIC

Fit_YOUTH FIT



Haze_746



Black / Orange_960

+
+
+

thirtytwo

TRANSITION IS OUR COLLECTION OF RIDER DRIVEN APPAREL
DESIGNED WITH 32 REPEL TREATED RIDEABLE FABRICS TO CREATE
PIECES THAT BLUR THE LINE BETWEEN TECHNICAL OUTERWEAR
AND FASHION. STYLES THAT CAN EFFORTLESSLY TAKE YOU FROM
THE SNOW TO THE STREET.



RIDE





8140000771

8130001203

8130001202

8140000772

S I G -



U L

R I E S

COLLECTION

SIGNATURE SERIES
Zeb Powell

[32]
 SIGNATURE SERIES.
 FOR SNOWBOARDING USE.
 RIDER DRIVEN SNOWBOARDING.



ThirtyTwo
 Zeb
 Powell
 Collection

Black
 White
 Heather / Grey

8130001210

32 X ZEB POWELL

thirtytwo

ZEB REST STOP PUFFY

JACKET

FEATURES

- + 100D 4 Way Stretch Polyester
- + 32 REPEL
- + 300G Synthetic Down Fill
- + YKK® AquaGuard® Matte Coil Zippers
- + Internal Media Pocket
- + Brushed Tricot Pocket Lining
- + Lycra Wrist Hem
- + Bungee Hem Cinch
- + Extended Collar

Code_ 8130001202

Size_ S, M, L, XL, XXL

Fabric_ 100D POLYESTER 4 WAY STRETCH WITH DWR & SYNTHETIC FILL



Black_001

Back View

ZEB REST STOP PUFFY

VEST

FEATURES

- + 100D 4 Way Stretch Polyester
- + 32 REPEL
- + 300G Synthetic Down Fill
- + YKK® AquaGuard® Matte Coil Zippers
- + Internal Media Pocket
- + Brushed Tricot Pocket Lining
- + Lycra Wrist Hem
- + Bungee Hem Cinch

Code_ 8130001203

Size_ S, M, L, XL, XXL

Fabric_ 100D POLYESTER 4 WAY STRETCH WITH DWR & SYNTHETIC FILL



Black / Charcoal_553

Back View

ZEB TECH L/S

FEATURES

- + 100% Wicking and Antimicrobial Polyester
- + Custom Mesh Jacquard
- + Relaxed Fit
- + Hidden On-Seam Zipper
- + Screenprint Graphic

Code_B130001208

Size_S, M, L, XL, XXL

Fabric_100% POLYESTER



Black_001

Back View

ZEB TECH S/S

FEATURES

- + 100% Wicking and Antimicrobial Polyester
- + Custom Mesh Jacquard
- + Relaxed Fit
- + Hidden On-Seam Zipper
- + Screenprint Graphic

Code_B130001209

Size_S, M, L, XL, XXL

Fabric_100% POLYESTER



Black_001

Back View

ZEB TECH

HOODIE

FEATURES

- + 32 REPEL
- + 32 Drawstrings
- + Kangaroo Pocket
- + 3-Panel Hood Construction
- + Ribbed Cuff and Hem

Code_8130001210

Size_S, M, L, XL, XXL

Fabric_300GSM 60% COTTON / 40% POLYESTER WITH DWR



Light Blue_450

Back View



Black / Charcoal_553

ZEB

SHORT

FEATURES

- + Wicking Dry Mesh with Polar Fleece Lining
- + Adjustable waistband
- + Side pockets
- + Woven damask label
- + Light touch plastisol ink

Code_8130001211

Size_S, M, L, XL, XXL

Fabric_100% POLYESTER DRY MESH WITH FLEECE LINING



Black_001

Back View

BEANIE ZEB



Black / Blue_587

FEATURES

- + Fine Ribbed Knit
- + Two Tone Yarns
- + Standard Fit
- + Patch Logo

Code_ B140000771

Size_ ONE SIZE

Fabric_ 100% ACRYLIC

HAT ZEB CAMP



Black_001

FEATURES

- + 5 Panel Deconstructed Camp Hat with Flat Brim
- + Embroidered Crown
- + Nylon Strap with Plastic Clip Buckle
- + 32 Clamp Logo
- + 32 REPEL

Code_ B140000773

Size_ ONE SIZE

Fabric_ 220 GM FLEECE POLYESTER W/DWR AND NYLON FACING



Back View

VISOR ZEB



Light Blue_450

FEATURES

- + 320G Acrylic Knit Visor
- + Adjustable Velcro Back Strap
- + Damask Woven Label
- + 32 Clamp Logo

Code_ B140000772

Size_ ONE SIZE

Fabric_ 100% ACRYLIC



Back View

SOCK SIGNATURE MERINO



Black / Blue_587

FEATURES

- + ASI Advanced Sock Integration Fit
- + Non Mulsed Merino Wool With Antimicrobial Spandex
- + Stay Up Rib Cuff
- + Logo Embroidery On Cuff
- + Snug Fit Heel
- + Arch Support Rib Knit
- + Compression Ankle Rib Band
- + Achilles, Calf, And Shin Cushion
- + Toe And Heel Cushion
- + Reinforced Ghost Seam Toe Box

Code_ B140000764

Size_ S/M, L/XL Fit_ ASI FIT Weight_ MIDWEIGHT

Fabric_ 41.5% MERINO / 41.5% ACRYLIC / 15% NYLON / 2% SPANDEX

G
R
E
N
I
E
R



SIG_SERIES

GRENIER

REST STOP PUFF VEST

FEATURES

- + 100D 4 Way Stretch Polyester
- + 32 REPEL
- + 300G Synthetic Down Fill
- + Reflective YKK® AquaGuard® Matte Coil Zippers
- + Internal Media Pocket
- + Brushed Tricot Pocket Lining
- + Lycra Wrist Hem
- + Bungee Hem Cinch

Code_8130001203

Size_ S, M, L, XL, XXL

Fabric_100D POLYESTER 4 WAY STRETCH WITH DWR & SYNTHETIC FILL



Black / Chrome_583

REST STOP ZIP-UP SHIRT

FEATURES

- + Custom Printed Fleece
- + 32 REPEL
- + Garment Washed for soft hand feel
- + Water Repellent Zipper
- + Front chest pockets
- + Side Hand Pockets
- + 32 Branding

Code_8130001206

Size_ S, M, L, XL, XXL

Fabric_220 GM FLEECE POLYESTER W/DWR



Black / Charcoal_553

SIG_SERIES



STEVEN'S
Soft Shell

32 FLANNEL SHIRT

FEATURES

- + 3296 Flannel Shirt
- + Garment Washed for soft hand feel
- + Hidden Plastic Snap Buttons
- + Front chest pocket
- + 32 Branding
- + Relaxed Fit

Code_8130001207

Size_ S, M, L, XL, XXL

Fabric_100% POLYESTER



Black / Red_595

32 RAIN JACKET

FEATURES

- + Waterproof Stretch Fabric
- + Snap Closure buttons
- + Deep Utility Pockets
- + Toggle Hood System
- + Relaxed Fit

Code_8130001201

Size_ S, M, L, XL, XXL

Fabric_100% RUBBER



Forrest_351

STEVEN'S CREW

FEATURES

- + 10 oz. Fleece Crewneck
- + Underarm gusset
- + Neck twill taping
- + Rib at sleeve cuff and bottom opening
- + Light Touch Plastisol Ink

Code_8130001218

Size_ S, M, L, XL, XXL

Fabric_80% COTTON 20% POLYESTER



Black_001

REST STOP SHIRT

FEATURES

- + 220 GSM Micro Polar Fleece
- + 32 REPEL
- + Garment Washed for Soft Hand Feel
- + Hidden Spring Snap Buttons
- + Front Chest Pockets
- + 32 Branding
- + Woven Chest Label

Code_B130001205

Size_S, M, L, XL, XXL

Fabric_220 GM FLEECE POLYESTER W/DWR



Black_001



Blue / Grey_433



Black / Charcoal_553



Military_343

REST STOP HOODIE

FEATURES

- + 220 GSM Micro Polar Fleece
- + 32 REPEL
- + Garment Washed for Soft Hand Feel
- + 32 Drawstrings
- + Kangaroo Pocket with Hidden Zippers
- + 3-Panel Hood Construction
- + Quick Stash Sleeve Pass Pocket
- + Ribbed Cuff and Hem
- + Woven Chest Label

Code_B130001204

Size_S, M, L, XL, XXL

Fabric_220 GM FLEECE POLYESTER W/DWR



Black / Olive_592

Back View



Black_001

REST STOP

ANDRAK

FEATURES

- + 220 GSM Micro Polar Fleece
- + 32 REPEL
- + Garment Washed for Soft Hand Feel
- + Nylon Paneling
- + Reverse Coil Zippers
- + Woven Chest Label
- + Plastic Spring Snaps
- + Front chest pocket with Zipper
- + Side Zip Pockets
- + Woven Chest Table

Code_B130001212

Size_S, M, L, XL, XXL

Fabric_220 GM FLEECE POLYESTER W/DWR



Military_343

Back View



Black_001

REST STOP

PANT

FEATURES

- + 220 GSM Micro Polar Fleece
- + 32 REPEL
- + 4-Way Stretch Nylon Butt Panel
- + Elastic Waist with Drawcord
- + Zippered Fly, Reverse Coil Zippers
- + Garment Washed for Soft Hand Feel
- + Easy Access Welt Pockets
- + Pass Pocket on Leg
- + Printed Logos

Code_B130001213

Size_S, M, L, XL, XXL

Fabric_220 GM FLEECE POLYESTER W/DWR



Black_001

Back View

FRANCHISE TECH

HOODIE

FEATURES

- + 32 Drawstrings
- + Kangaroo Pocket With Hidden Zippers
- + 3-Panel Hood Construction
- + Quick Stash Sleeve Pass Pocket
- + Ribbed Cuff And Hem
- + Screenprint Graphic

Code_B130001214

Size_S, M, L, XL, XXL

Fabric_300 GSM 60/40. FLEECE COTTON POLYESTER W/DWR



White_100

Back View



Black_001

DOUBLE TECH

HOODIE

FEATURES

- + 32 Drawstrings
- + Kangaroo Pocket
- + 3-Panel Hood Construction
- + Ribbed Cuff And Hem
- + Screenprint Graphic

Code_B130001164

Size_S, M, L, XL, XXL

Fabric_300 GSM 60/40. FLEECE COTTON POLYESTER W/DWR



Royal_430

Back View



Grey / Orange_097



Black / Charcoal_553



R
I
D
E
L
I
T
E
R
I
D
E
L
I
T
E
L
O
N
G
E
R

RIDELITE L/S

BASE LAYER 2022 / 2023

32 RIDELITE

thirtytwo



RIDELITE L/S

BASE LAYER

2022 / 2023

32 RIDELITE



RIDELITE L/S

BASE LAYER

2022 / 2023

32 RIDELITE

RIDELITE L/S

SHIRT

FEATURES

- + Cool Pass Moisture Wicking Yarns
- + Flatlock Stitch Construction
- + Sleeve Cuff Thumb Holes
- + Screenprint Graphic

Code_813000166

Size_S, M, L, XL, XXL

Fabric_95/5 POLY + SPANDEX BLEND W/COOL PASS YARNS



Black / Red_595

Back View

Orange_800

Black_001

RIDELITE

PANT

FEATURES

- + Cool Pass Moisture Wicking Yarns
- + Flatlock Stitch Construction
- + Elastic Waistband With Woven Double Logo
- + Screenprint Graphic

Code_813000167

Size_S, M, L, XL, XXL

Fabric_95/5 POLY SPANDEX BLEND W/COOL PASS YARNS



Black / Red_595

Back View

Black_001

RIDELITE MERINO L/S

FEATURES

- + Merino Wool
- + Flatlock Stitch Construction
- + Sleeve Cuff Thumb Holes
- + Screenprint Graphic

Code_813000169

Size_S, M, L, XL, XXL

Fabric_80% MERINO WOOL + 20% NYLON



Black / Black_003

Back View

RIDELITE MERINO

FEATURES

- + Merino Wool
- + Flatlock Stitch Construction
- + Elastic Waistband With Woven Double Logo
- + Screenprint Graphic

Code_813000170

Size_S, M, L, XL, XXL

Fabric_80% MERINO WOOL + 20% NYLON



Black / Black_003

RIDELITE MERINO

FEATURES

- + 180 GSM Polar Fleece Knee Insulation
- + Moisture Wicking And Antimicrobial
- + Flatlock Stitch Construction
- + Elastic Waistband With Woven Double Logo
- + Screenprint Graphic

Code_813000171

Size_S, M, L, XL, XXL

Fabric_80% MERINO WOOL + 20% NYLON



Black / Black_003

Back View

P R I M E



 HOODRATS
THIRTY TWO

(03)
TWO OF THE BEST TO EVER DO IT.
FOR SNOWBOARDING USE.
RIDER DRIVEN SNOWBOARDING.



ThirtyTwo
Hood Rats
Hoodies
Tees

Black

White

Heather / Grey

8137000072

thirtytwo

32 PRINTABLES

DOUBLE TEE

SHIRT

FEATURES

- + Combed Ring Spun Fine Jersey
- + 160 Grams, 4.4 Ounces
- + Set In Collar / 3/4" Rib Height
- + Taped Shoulder To Shoulder
- + 32 Woven Clamp Label
- + Light Touch Plastisol Ink

Code_B130001173

Size_S, M, L, XL, XXL

Fabric_100% COTTON



Black_001



White / Black_110



Navy / Gum_460

32 L/S

SHIRT

FEATURES

- + Combed Ring Spun Fine Jersey
- + 160 Grams, 4.4 Ounces
- + Set In Collar / 3/4" Rib Height
- + Taped Shoulder To Shoulder
- + 32 Woven Clamp Label
- + Light Touch Plastisol Ink

Code_B130001174

Size_S, M, L, XL, XXL

Fabric_100% COTTON



Navy / Gum_460



Black / Blue_587

32 ART TEE

SHIRT

FEATURES

- + Combed Ring Spun Fine Jersey
- + 160 Grams, 4.4 Ounces
- + Set In Collar / 3/4" Rib Height
- + Taped Shoulder To Shoulder
- + 32 Woven Clamp Label
- + Light Touch Plastisol Ink

Code_B130001219

Size_S, M, L, XL, XXL

Fabric_100% COTTON



Black_001

Charcoal / Heather_011

Black / White_976

32 ART L/S

SHIRT

FEATURES

- + Combed Ring Spun Fine Jersey
- + 160 Grams, 4.4 Ounces
- + Set In Collar / 3/4" Rib Height
- + Taped Shoulder To Shoulder
- + 32 Woven Clamp Label
- + Light Touch Plastisol Ink

Code_B130001221

Size_S, M, L, XL, XXL

Fabric_100% COTTON



Black / Orange_960

White_100

Black_001

DOUBLE HOODIE

FEATURES

- + 10 oz. Fleece
- + Underarm Gusset
- + DTM Hood Drawstring
- + Neck Twill Taping
- + Rib At Sleeve Cuff And Bottom Opening
- + Pouch Pocket
- + Light Touch Plastisol Ink

Code_8130001176

Size_S, M, L, XL, XXL

Fabric_80% COTTON / 20% POLYESTER



Military_343



Black / Red_595

SPRING BREAK HOODIE

FEATURES

- + 10 oz. Fleece
- + Underarm Gusset
- + DTM Hood Drawstring
- + Neck Twill Taping
- + Rib At Sleeve Cuff And Bottom Opening
- + Pouch Pocket
- + Light Touch Plastisol Ink

Code_8137000071

Size_S, M, L, XL, XXL

Fabric_80% COTTON / 20% POLYESTER



Royal_430



White_100

32 ART

HOODIE



Black_001

Grey / Heather_043

Black / Orange_960

FEATURES

- + 10 oz. Fleece
- + Underarm Gusset
- + DTM Hood Drawstring
- + Neck Twill Taping
- + Rib At Sleeve Cuff And Bottom Opening
- + Pouch Pocket
- + Light Touch Plastisol Ink

Code_8130001215

Size_S, M, L, XL, XXL

Fabric_80% COTTON / 20% POLYESTER

32 ART

JOGGER



Black_001

Back View

FEATURES

- + 8 oz. Fleece
- + Classic Fit for Loose Comfort
- + Seamless Sides
- + Covered Elastic Waistband
- + Elasticized Cuffs

Code_8130001217

Size_S, M, L, XL, XXL

Fabric_50% COTTON + 50% POLYESTER

YOUTH HOODIE DOUBLE

FEATURES

- + 7.8 oz. Fleece
- + Neck Twill Taping
- + Rib at Sleeve Cuff and Bottom Opening
- + Pouch Pocket
- + Light Touch Plastisol Ink

Code_8330000020

Size_S, M, L, XL

Fabric_80% COTTON / 20% POLYESTER



Orange_800



Black / Red_595

YOUTH HOODIE FLAME

FEATURES

- + 7.8 oz. Fleece
- + Neck Twill Taping
- + Rib at Sleeve Cuff and Bottom Opening
- + Pouch Pocket
- + Light Touch Plastisol Ink

Code_8330000023

Size_S, M, L, XL

Fabric_80% COTTON / 20% POLYESTER



Black_001



Back View

HOOD RATS COACHES

JACKET

FEATURES

- + 330 GM Bonded Fleece
- + 2,000K Waterproof Coating
- + Snap Buttons
- + Draw cord hem
- + Front Pockets
- + 32 clamp logo



Black / Blue_587

Code_8137000072

Size_S, M, L, XL, XXL

Fabric_92% POLYESTER / 8% SPANDEX WITH DWR

HOOD RATS

BEANIE

FEATURES

- + Wide Ribbed Knit
- + Standard Fit
- + Embroidered Logo



Black_001

Code_8147000028

Size_ONE SIZE

Fabric_100% ACRYLIC

HOOD RATS

HOODIE

FEATURES

- + 0 oz. Fleece
- + Underarm Gusset
- + OTM Hood Drawstring
- + Neck Twill Taping
- + Rib At Sleeve Cuff And Bottom Opening
- + Pouch Pocket
- + Light Touch Plastisol Ink



Black / Blue_587

Black / Orange_960

Black / Red_595

Code_8137000073

Size_S, M, L, XL, XXL

Fabric_80% COTTON / 20% POLYESTER

HOOD RATS L/S

FEATURES

- + Combed Ring Spun Fine Jersey
- + 150 Grams, 4.4 Ounces
- + Set In Collar / 3/4" Rib Height
- + Taped Shoulder To Shoulder
- + 32 Woven Clamp Label
- + Light Touch Plastisol Ink

Code_8137000074

Size_S, M, L, XL, XXL

Fabric_100% COTTON



Black / Orange_960

Black / Blue_587

HOOD RATS

FEATURES

- + Combed Ring Spun Fine Jersey
- + 150 Grams, 4.4 Ounces
- + Set In Collar / 3/4" Rib Height
- + Taped Shoulder To Shoulder
- + 32 Woven Clamp Label
- + Light Touch Plastisol Ink

Code_8137000075

Size_S, M, L, XL, XXL

Fabric_100% COTTON



Black / Red_595

Black / Orange_960



R I E S

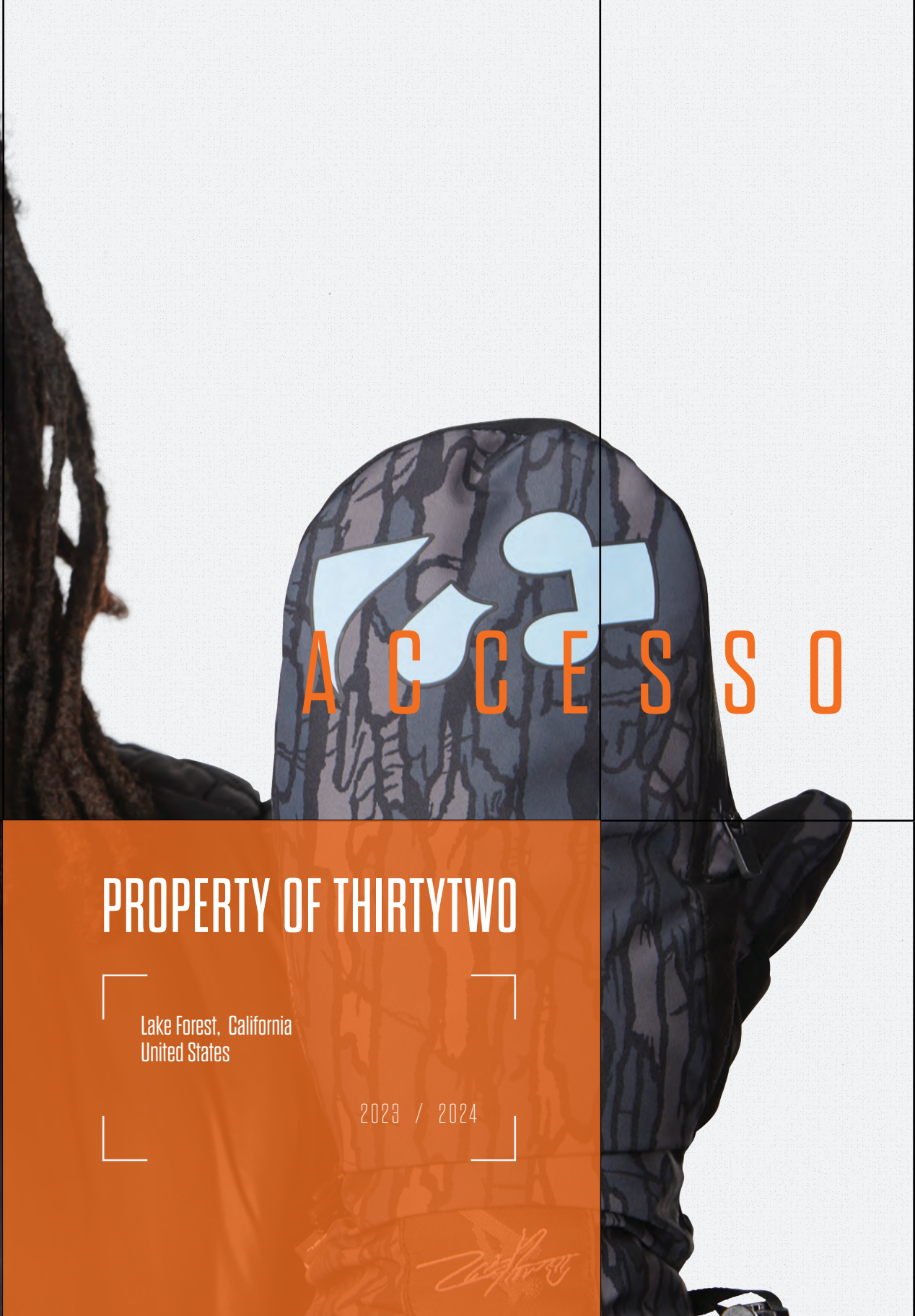

A C C E S S O

PROPERTY OF THIRTYTWO

Lake Forest, California
United States

2023 / 2024





814000761



814000766



thirtytwo

- GLOVES
- BEANIES
- HATS
- BELTS

ENGINEERED FOR THE 32 TEAM
RIDER DRIVEN SNOWBOARDING

CORD MITT XLT

FEATURES

- + Taped Seams
- + Finger Free Side Zip
- + Conductive Thumb Fabric
- + 32 Silicon Printed Water Resistant Palm
- + Brushed Tricot Lining
- + Micro Suede Thumb
- + Cinch Wrist Closure
- + Removable Wrist Leash



Black / Black / Reflective_541



Black_001

Code_8140000757

Size_S/M, L/XL

32 REPEL 15k_15.000MM WATERPROOFING / 15.000GM2 BREATHABILITY

Fabric_15/15 REPEL 4-WAY STRETCH FUSED 2 LAYER FABRIC

GATEWAY MITT

FEATURES

- + Taped Seams
- + Conductive Thumb Fabric
- + 32 Silicon Printed Water Resistant Palm
- + Brushed Tricot Lining
- + Micro Suede Thumb
- + Velcro and Spandex Wrist Closure
- + Removable Wrist Leash



Black_001



Charcoal_010



Black / Green_985

Code_8140000758

Size_S/M, L/XL

32 REPEL 15k_15.000MM WATERPROOFING / 15.000GM2 BREATHABILITY

Fabric_15/15 REPEL 4-WAY STRETCH FUSED 2 LAYER FABRIC

CORD MITT

FEATURES

- + Taped Seams
- + Finger Free Side Zip
- + Conductive Thumb Fabric
- + 32 Grip Tech Water Resistant Palm
- + Brushed Tricot Lining
- + Micro Suede Thumb
- + Cinch Wrist Closure
- + Removable Wrist Leash



Black / Black_003



Black / White_976

Khaki_255



Military_343

Code_8140000756

Size_S/M, L/XL

32 REPEL 15k_15.000MM WATERPROOFING / 15.000GM2 BREATHABILITY

Fabric_15/15 REPEL 4-WAY STRETCH FUSED 2 LAYER FABRIC

LASHED GLOVE

FEATURES

- + 100G Synthetic Down Insulation
- + Taped Seams
- + Conductive Forefinger Fabric
- + 32 Grip Tech Water Resistant Palm
- + Brushed Tricot Lining
- + Micro Suede Thumb For Snow Wipe
- + Power Cinch Wrist Closure
- + Removable Wrist Leash



Black / Black_003



Khaki_255

Code_8140000759

Size_S/M, L/XL

32 REPEL 15k_15.000MM WATERPROOFING / 15.000GM2 BREATHABILITY

Fabric_15/15 REPEL 4-WAY STRETCH FUSED 2 LAYER FABRIC

TM
MITT

FEATURES

- + 300G Synthetic Down Insulation
- + Taped Seams
- + Conductive Thumb Fabric
- + Brushed Tricot Lining
- + Micro Suede Thumb For Snow Wipe
- + Ladder Lock Wrist Cinch
- + Power Cinch Gauntlet Closure
- + Removable Wrist Leash

Code_ B140000760

Size_ S/M, L/XL

32 REPEL 15k_20.000MM WATERPROOFING / 20.000GM2 BREATHABILITY

Fabric_ 15/15 REPEL 4-WAY STRETCH FUSED 2 LAYER FABRIC



Military_343



Black / Black_003

W'S CORP
MITT

FEATURES

- + Taped Seams
- + Finger Free Side Zip
- + Conductive Thumb Fabric
- + 32 Grip Tech Water Resistant Palm
- + Brushed Tricot Lining
- + Micro Suede Thumb
- + Cinch Wrist Closure
- + Removable Wrist Leash

Code_ 8240000133

Size_ S/M, L/XL

32 REPEL 15k_15.000MM WATERPROOFING / 15.000GM2 BREATHABILITY

Fabric_ 15/15 REPEL 4-WAY STRETCH FUSED 2 LAYER FABRIC



Tan_280



Black_001

OUTPOST
MITT

FEATURES

- + 300G Synthetic Down Insulation
- + Taped Seams
- + Conductive Thumb Fabric
- + Brushed Tricot Lining
- + Micro Suede Thumb For Snow Wipe
- + Velcro Wrist Closure
- + Removable Wrist Leash

Code_ B140000761

Size_ S/M, L/XL

32 REPEL 15k_15.000MM WATERPROOFING / 15.000GM2 BREATHABILITY

Fabric_ WATER REPELLENT REPEL TANNED GOAT LEATHER



Black_001



Natural_101

CORP KIDS
MITT

FEATURES

- + 100G Synthetic Down Insulation
- + Taped Seams
- + Conductive Thumb Fabric
- + Zippered Warmer Pocket
- + Brushed Tricot Lining
- + Micro Suede Thumb For Snow Wipe
- + Ladder Lock Wrist Cinch
- + Customizable Internal Name Tag
- + Power Cinch Wrist Closure
- + Removable Wrist Leash

Code_ 8340000013

Size_ S/M, L/XL

32 REPEL 15k_15.000MM WATERPROOFING / 15.000GM2 BREATHABILITY

Fabric_ 15/15 REPEL 4-WAY STRETCH FUSED 2 LAYER FABRIC



Black / Black_003



Haze_746



Black / Green_985

BASIXX BEANIE



Black_001



Black / Orange_960



Military_343



Yellow_700



White_100

FEATURES

- + Wide Ribbed Knit
- + Standard Fit
- + Embroidered Logo

Code_8140000748

Size_ONE SIZE

Fabric_100% ACRYLIC

POM BEANIE



Black / Blue_587



Military_343



Charcoal_010

FEATURES

- + Fine Ribbed Knit
- + Extended Fit
- + Jacquard Logo
- + Pom Top

Code_8140000778

Size_ONE SIZE

Fabric_60% POLYLANA RECYCLED / 40% ACRYLIC

BASIXX BEANIE 3 PACK



Assorted_999

FEATURES

- + Wide Ribbed Knit
- + Standard Fit
- + Embroidered Logo

Code_8140000750

Size_ONE SIZE

Fabric_100% ACRYLIC

MUSHROOM BEANIE



Black_001

FEATURES

- + Fine Ribbed Knit
- + Extended Fit
- + Jacquard Art Logo

Code_8140000774

Size_ONE SIZE

Fabric_100% ACRYLIC

STEEL

BEANIE



Black_001

FEATURES

- + Fine Ribbed Knit
- + Extended Fit
- + Jacquard Art Logo

Code_8140000775

Size_ONE SIZE

Fabric_100% ACRYLIC

DOUBLE OVERLAP

BEANIE



Military_343

FEATURES

- + Fine Ribbed Knit
- + Extended Fit
- + Jacquard Logo

Code_8140000776

Size_ONE SIZE

Fabric_60% POLYLANA RECYCLED / 40% ACRYLIC



Grey / Heather_043



Orange_800

STRIDE

BEANIE



Black / Blue_587

FEATURES

- + Fine Ribbed Knit
- + Extended Fit
- + Clamp Logo

Code_8140000777

Size_ONE SIZE

Fabric_60% POLYLANA RECYCLED / 40% ACRYLIC



Military_343



Tan_260

PATCH

BEANIE



Black_001

FEATURES

- + Fine Ribbed Knit
- + Extended Fit
- + Patch Logo

Code_8140000751

Size_ONE SIZE

Fabric_100% ACRYLIC



Orange_800



White_100

REST STOP

BEANIE



Khaki_255

FEATURES

- + 100D 4 Way Stretch Polyester
- + 32 REPEL
- + Double Layer Construction

Code_8140000779

Size_ONE SIZE

Fabric_220 GM FLEECE POLYESTER W/DWR



Black_001

KNIT VISOR

BALACLAVA



Black / Orange_960

FEATURES

- + Wide Ribbed Knit
- + Extended Fit
- + Full Face Balacava with Visor
- + Jacquard logo

Code_8140000781

Size_ONE SIZE

Fabric_100% ACRYLIC



Military_343

White_100

RESTOP BALACLAVA

BEANIE



Military_343

FEATURES

- + 100D 4 Way Stretch Polyester
- + 32 REPEL
- + Screenprint Graphic
- + Toggle Face Cinch

Code_8140000780

Size_ONE SIZE

Fabric_220 GM FLEECE POLYESTER W/DWR



Black_001

DOUBLE SNAPBACK

HAT



Charcoal / Heather_011

FEATURES

- + 6 Panel Snapback With Flat Brim
- + Soft Poplin Reinforcement
- + 3 3/4" Crown
- + Embroidered Crown
- + 32 Clamp Logo

Code_8140000753

Size_ONE SIZE

Fabric_85% ACRYLIC / 15% WOOL



Black_001

CAMP HAT



Military_343



Black_001

FEATURES

- + 5 Panel Deconstructed Camp Hat with Flat Brim
- + Embroidered Crown
- + Nylon Strap with Plastic Clip Buckle
- + 32 Clamp Logo
- + 32 REPEL

Code_8140000782

Size_ONE SIZE

Fabric_220 GM FLEECE POLYESTER W/DWR AND NYLON FACING

32 LACE UP BELT



Black_001



Orange_800

FEATURES

- + 1.6cm Wide Shoe Lace Belt
- + Metal Branded Aglet
- + 32 Woven Label
- + 160cm In Length

Code_8140000754

Size_ONE SIZE

Fabric_100% POLYESTER 600D

32 CUT-OUT BELT



Black_001



Orange_800

FEATURES

- + 1" Elastic Webbing
- + Adjustable Strap
- + Low Profile Plastic Buckle
- + Laser Cut Logo

Code_8140000755

Size_ONE SIZE

Fabric_100% POLYESTER

32 PATCH KIT



FEATURES

- + Embroidered Patch Kit
- + Merrowed Edges
- + Iron On Backing

Code_8140000783

Size_ONE SIZE

Fabric_100% POLYESTER

Assorted_999

SLAT WALL SHELF



FEATURES

Hold your boots up loud and proud. Made of the strongest plastic earth has to offer. One boot per shelf.

Code_8670000133

32 FLOOR MAT



FEATURES

Make your shop look oh so sexy when customers walk in that door. Made of the finest nylon and rubber.

Code_8670000130

32 TABLE CLOTH



FEATURES

Two sizes, big tables or small tables. Bring one over to your mom's house and say, look mom, I finally got a table cloth I like!

Code_8670000154 - 6 FOOT (SMALL)
Code_8670000155 - 8 FOOT (LARGE)

32 BANNERS



FEATURES

Two sizes, one for big shops and one for small shops. Made from the most durable vinyl, these banners are built to last.

Code_8670000127 - 2x4 Vinyl Banner
Code_8670000128 - 4x8 Vinyl Banner

32 BENCH



FEATURES

Have your customers sit on the sturdy, solid plastic 32 bench while they get fit with the world's best boots.

Code_8670000132

BRANNOCK DEVICE



FEATURES

Most consumers don't even know what foot size they are, so now you have the tool to show them exactly what size foot they have. US sizing only.

Code_8650000039

Sizes_US Sizing

ELITE LINER

FEATURES

Injection molded with high rebound energy foam providing excellent support, medium flex and will not break down like traditional liners. Lined with intuition foam making this liner 100% heat moldable. Customize fit with the Heel Hold Kit.

Code_8640000045 | Sizes_5-13



Black_001

FIT SYSTEM

FEATURES

A crucial part of the tools needed to customize your new boots.

Code_8670000059 = 110v

Sizes_No Size



Black / Orange_960

ELITE FOOTBEDS

FEATURES

Molded Energy Foam with Heel Cradle & Customizable Adaptive Arch Support

Code_8640000046 | Single

Sizes_
S: 7-8
M: 8.5-9.5
L: 10-11
XL: 11.5-13



Assorted_999

FIT KIT

FEATURES

A crucial part of the tools needed to customize your new boots.

Code_8640000023

Sizes_No Size



Assorted_999

HEEL HOLD KIT

FEATURES

Fit System Heel Hold Kit — a crucial part of the tools needed to customize your new boots.



Assorted_999

Code_81400000258
 Sizes_No Size

LACE BOX

FEATURES

20 pack of laces, fits any size boots. Black, white, orange, purple and blue. 100% poly.



Assorted_999

Black / White_976

Code_8640000027
 Sizes_No Size

32 STICKERS



ThirtyTwo Dale
 25 stickers per color. Orange, White, Grey and Black.



ThirtyTwo Double
 25 stickers per color. Orange, White, Grey and Black.



ThirtyTwo Die-Cut Sticker Pack
 4 Dale & 4 Double — 2 of Orange, White, Grey & Black.

Name_ThirtyTwo Dale / Die Cut / 100 pack | Code_8670000129
 Name_ThirtyTwo Double / Die-Cut / 100 pack | Code_8670000131
 Name_32 Die-Cut Sticker Pack / 8 pack | Code_8650000033
 Name_32 Board Sticker Pack / 6 Clear stickers | Code_8670000172
 Name_Assorted Sticker Pack / Graphic Stickers | Code_8670000181



32 Board Sticker Pack



Assorted Sticker Pack

32 BEER KOOZIE

FEATURES

SALUTE TO THE SNOW GODS!



Code_8650000057

32 LIGHTER

FEATURES

WE'RE LIGHTER - FIRE IT UP!



Code_8650000059

32 PLATE FRAME

FEATURES

Let the people tailgating you know you're much cooler than they are.



Code_8650000058

32 RETAIL DISPLAY

FEATURES

Outerwear, accessories, and socks.

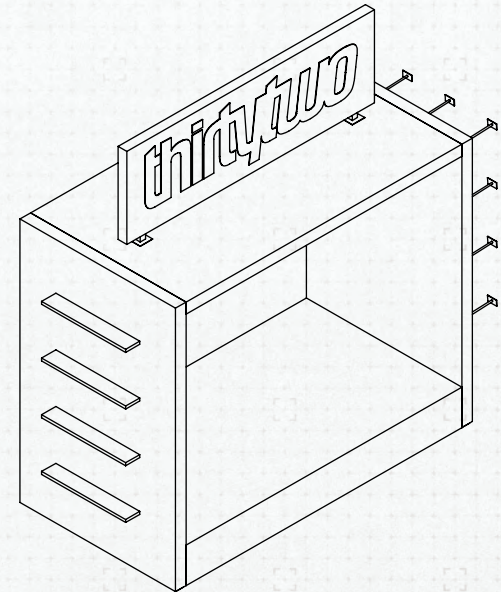

Code_8670000182 - 000

GRENIER CUTOUT

CARDBOARD

FEATURES

Pros love to have photos taken of them, now they don't even need to be present. The perfect photo op for your shop - gotta catch 'em all!

Code_8670000177 - CHRIS GRENIER



thirtytwo

JP CUTOUT

CARDBOARD

FEATURES

Pros love to have photos taken of them, now they don't even need to be present. The perfect photo op for your shop - gotta catch 'em all!

Code_8670000178 - JP WALKER



thirtytwo

STEVENS CUTOUT

CARDBOARD

FEATURES

Pros love to have photos taken of them, now they don't even need to be present. The perfect photo op for your shop - gotta catch 'em all!

Code_8670000179 - SCOTT STEVENS



thirtytwo

ZEB CUTOUT

CARDBOARD

FEATURES

Pros love to have photos taken of them, now they don't even need to be present. The perfect photo op for your shop - gotta catch 'em all!

Code_8670000180 - ZEB POWELL



thirtytwo

10X10 BACK DROP

Code_8670000184

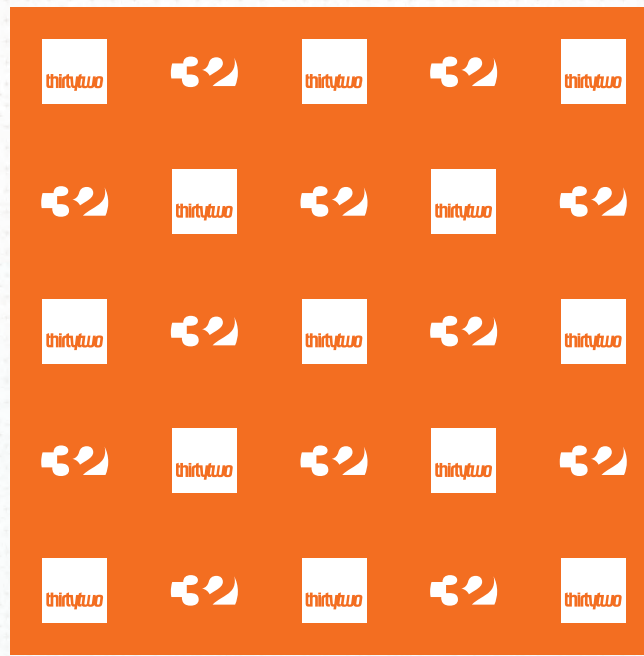

32 AIR-FRESHENER

Code_8670000185



thirtytwo BOOT OVERVIEW





thirtytwo WOMENS BOOTS



thirtytwo YOTUH BOOTS



thirtytwo ALL TERRAIN FOOTWEAR



thirtytwo OUTERWEAR JACKETS



thirtytwo OUTERWEAR PANTS



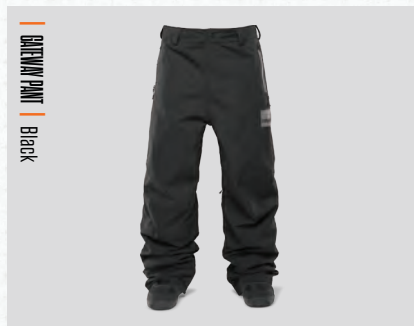

thirtytwo
WOMENS
OUTERWEAR

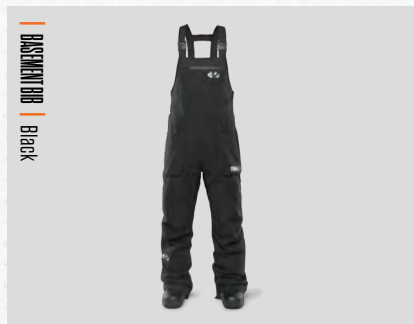

thirtytwo
YOUTH
OUTERWEAR



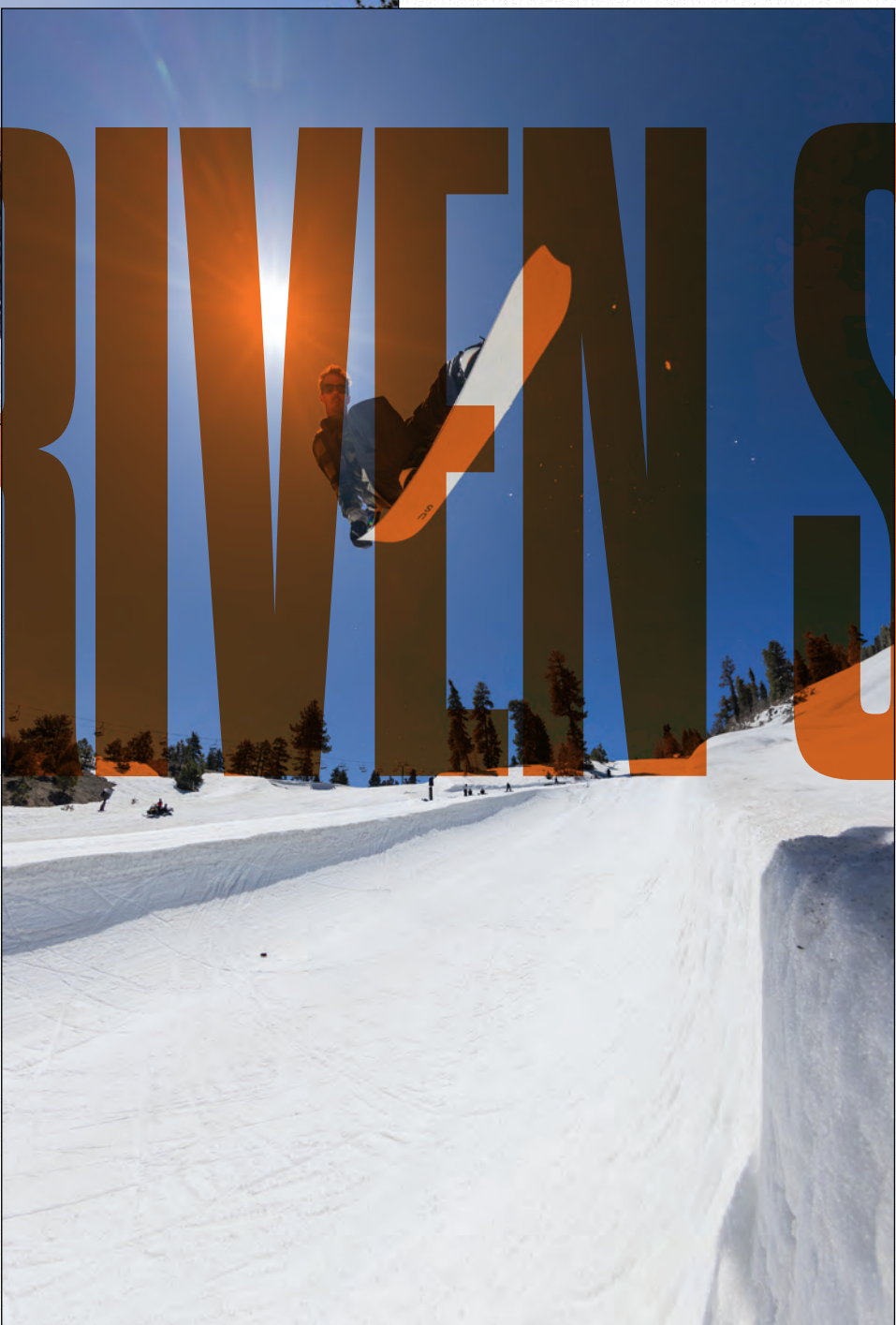
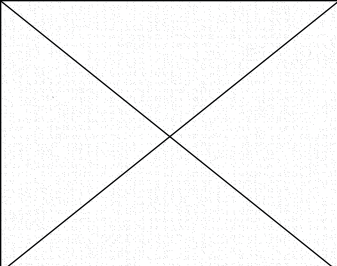

RIDER RIVERS



OUTERWEAR TEAM

SIGNATURE

JP Walker

Scott Stevens

Chris Grenier

Zeb Powell

Phil Hanson

Pat Fava

Austin Visintainer

Toni Kerkela

Stefi Luxton

Joey Fava

Fynn Bullock

Chris Bradshaw

PRO BOOTS TEAM

Jeremy Jones

Bode Merrill

Austen Sweetin

Elena Hight

Halldor Helgason

Joe Sexton

Scott Blum

Desiree Melancon



SINCE 1995

SNOWBOARDING

BUILT FOR SNOWBOARDERS BY SNOWBOARDERS

